

BITSAT - Paper 2024

Solved Paper

Physics

1. You measure two quantities as $A = 1.0 \text{ m} \pm 0.2 \text{ m}$, $B = 2.0 \text{ m} \pm 0.2 \text{ m}$. We should report correct value for \sqrt{AB} as

A. $1.4 \text{ m} \pm 0.4 \text{ m}$

B. $1.41 \text{ m} \pm 0.15 \text{ m}$

C. $1.4 \text{ m} \pm 0.3 \text{ m}$

D. $1.4 \text{ m} \pm 0.2$

Ans. D

Solution:

Given, $A = 1.0 \text{ m} \pm 0.2 \text{ m}$, $B = 2.0 \text{ m} \pm 0.2 \text{ m}$

$$\text{Let } Y = \sqrt{AB} = \sqrt{(1.0)(2.0)} = 1.414 \text{ m}$$

Rounding off to two significant digits

$$\begin{aligned} Y &= 1.4 \text{ m} \\ \frac{\Delta Y}{Y} &= \frac{1}{2} \left[\frac{\Delta A}{A} + \frac{\Delta B}{B} \right] \\ &= \frac{1}{2} \left[\frac{0.2}{1.0} + \frac{0.2}{2.0} \right] \\ &= \frac{0.6}{2 \times 2.0} \\ \Rightarrow \Delta Y &= \frac{0.6Y}{2 \times 2.0} = \frac{0.6 \times 1.4}{2 \times 2.0} = 0.212 \end{aligned}$$

Rounding off to one significant digit,

$$\Delta Y = 0.2 \text{ m}$$

2. The dimensional formula of latent heat is:

A. $[M^0LT^{-2}]$

B. $[MLT^{-2}]$

C. $[M^0L^2T^{-2}]$

D. $[ML^2T^{-2}]$

Ans. C

Heat, $Q = mL$ where, $L =$ latent heat

$$\therefore L = \frac{Q}{m} = \frac{ML^2 T^{-2}}{M} = M^0 L^2 T^{-2}$$

3. The dimensions of coefficient of self inductance are

A. $[ML^2 T^{-2} A^{-2}]$

B. $[ML^2 T^{-2} A^{-1}]$

C. $[MLT^{-2} A^{-2}]$

D. $[MLT^{-2} A^{-1}]$

Ans. A

Energy stored in an inductor, $U = \frac{1}{2}LI^2$

$$\Rightarrow L = \frac{2U}{I^2}$$

$$[L] = \frac{[ML^2 T^{-2}]}{[A]^2} = [ML^2 T^{-2} A^{-2}]$$

4. A particle is moving in a straight line. The variation of position 'x' as a function of time 't' is given as $x = (t^3 - 6t^2 + 20t + 15)m$.

The velocity of the body when its acceleration becomes zero is:

A. 6 m/s

B. 10 m/s

C. 8 m/s

D. 4 m/s

Ans. C

Solution:

Displacement, $x = t^3 - 6t^2 + 20t + 15$

∴ Velocity, $v = \frac{dx}{dt} = 3t^2 - 12t + 20$

∴ Acceleration, $a = \frac{dv}{dt} = 6t - 12$

When $a = 0$

$$\Rightarrow 6t - 12 = 0 \Rightarrow t = 2 \text{ s}$$

$$\text{At } t = 2 \text{ s, } v = 3(2)^2 - 12(2) + 20 = 8 \text{ m/s}$$

5. The distance travelled by a particle starting from rest and moving with an acceleration $4/3 \text{ ms}^{-2}$, in the third second is:

- A. 6 m
- B. 4 m
- C. $10/3$ m
- D. $19/3$ m

Ans. C

Solution:

Distance travelled in the nth second is given by

$$t_n = u + \frac{a}{2}(2n - 1)$$

$$\text{put } u = 0, a = \frac{4}{3} \text{ ms}^{-2}, n = 3$$

$$\therefore d = 0 + \frac{4}{3 \times 2}(2 \times 3 - 1) = \frac{4}{6} \times 5 = \frac{10}{3} \text{ m}$$

6. A projectile is projected with velocity of 40 m/s at an angle θ with the horizontal. If R be the horizontal range covered by the projectile and after t seconds, its inclination with horizontal becomes zero, then the value of $\cot \theta$ is

[Take, $g = 10 \text{ m/s}^2$]

- A. $R/20t^2$
- B. $R/10t^2$
- C. $5R/t^2$

D. R/t^2

Ans. A

Solution:

At maximum height, inclination with horizontal becomes zero.

Time (taken by) projectile to reach maximum height,

$$t = \frac{u \sin \theta}{g}$$
$$\Rightarrow u = \frac{gt}{\sin \theta} \dots (i)$$

Since,

$$R = u \cos \theta \times (2t)$$

$$\Rightarrow \cos \theta = \frac{R}{2ut}$$

$$\Rightarrow \cos \theta = \frac{R}{2 \cdot \frac{gt}{\sin \theta} \cdot t}$$
$$= \frac{R \sin \theta}{2gt^2} \text{ (Using (i))}$$

$$\Rightarrow \cot \theta = \frac{R}{2gt^2} = \frac{R}{2 \times 10t^2} = \frac{R}{20t^2}$$

7. A rigid body rotates about a fixed axis with variable angular velocity equal to $\alpha - \beta t$, at the time t , where α, β are constants. The angle through which it rotates before it stops is

A. $\frac{\alpha^2}{2\beta}$

B. $\frac{\alpha^2 - \beta^2}{2\alpha}$

C. $\frac{\alpha^2 - \beta^2}{2\beta}$

D. $\frac{(\alpha - \beta)\alpha}{2}$

Ans. A

Solution:

$$\omega = \alpha - \beta t. \text{ Comparing with } \omega = \omega_0 - \alpha t$$

$$\text{Initial angular velocity} = \alpha$$

$$\text{Angular retardation} = \beta$$

$$\therefore \text{Angle rotated before it stops is } \frac{\alpha^2}{2\beta}. \text{ [using}$$

$$\omega^2 = \omega_0^2 + 2\beta\theta]$$

8. The range of the projectile projected at an angle of 15° with horizontal is 50 m. If the projectile is projected with same velocity at an angle of 45° with horizontal, then its range will be:

- A. 50 m
- B. $50\sqrt{2}$ m
- C. 100 m
- D. $100\sqrt{2}$ m

Ans. C

Solution:

Range of projectile

$$R = \frac{v^2 \sin 2\theta}{g} (\because R \propto \sin(2\theta))$$

$$\frac{R_1}{R_2} = \frac{\sin(2\theta_1)}{\sin(2\theta_2)} = \frac{\sin(2 \times 15)}{\sin(2 \times 45)} = \frac{\sin 30^\circ}{\sin 90^\circ}$$

$$\Rightarrow \frac{50}{R_2} = \frac{1}{2} \Rightarrow R_2 = 100 \text{ m}$$

9. A particle of mass m is projected with a velocity ' u ' making an angle of 30° with the horizontal. The magnitude of angular momentum of the projectile about the point of projection when the particle is at its maximum height h is:

A. $\frac{\sqrt{3}}{16} \frac{mu^3}{g}$

B. $\frac{\sqrt{3}}{2} \frac{mu^2}{g}$

C. $\frac{mu^3}{\sqrt{2}g}$

D. zero

Ans. A

Solution:

$$\text{Angular momentum, } L = mvH = mu \cos 30H$$

$$= mu \cos 30^\circ \times \frac{u^2 \sin^2 \theta}{2g} \left[\because H = \frac{u^2 \sin^2 \theta}{2g} \right]$$

$$= \frac{mu^3}{2g} \times \frac{\sqrt{3}}{2} \times \left(\frac{1}{2}\right)^2 = \frac{\sqrt{3}mu^3}{16g}$$

10. A body is thrown with a velocity of 9.8 ms making an angle of 30° with the horizontal. It will hit the ground after a time

A. 3.0 s

B. 2.0 s

C. 1.5 s

D. 1 s

Ans. D

Solution:

$$\text{Time of flight} = \frac{2u \sin \theta}{g}$$

$$= \frac{2 \times 9.8 \times \sin 30^\circ}{9.8} = 2 \times \frac{1}{2} = 1 \text{sec}$$

11. A light string passing over a smooth light pulley connects two blocks of masses m_1 and m_2 (where $m_2 > m_1$). If the acceleration of the system is $g/\sqrt{2}$, then the ratio of the masses m_1/m_2 is:

A. $\frac{\sqrt{2}-1}{\sqrt{2}+1}$

B. $\frac{1+\sqrt{5}}{\sqrt{5}-1}$

C. $\frac{1+\sqrt{5}}{\sqrt{2}-1}$

D. $\frac{\sqrt{3}+1}{\sqrt{2}-1}$

Ans. A

Solution:

Acceleration is given as:

$$a = \left(\frac{m_2 - m_1}{m_1 + m_2} \right) g$$

$$\Rightarrow \frac{g}{\sqrt{2}} = \left(\frac{m_2 - m_1}{m_1 + m_2} \right) g$$

$$\Rightarrow \sqrt{2}(m_2 - m_1) = m_1 + m_2$$

$$\Rightarrow \frac{m_1}{m_2} = \left(\frac{\sqrt{2}-1}{\sqrt{2}+1} \right)$$

12. A block of mass 1 kg is pushed up a surface inclined to horizontal at an angle of 60° by a force of 10 N parallel to the inclined surface as shown in figure. When the block is pushed up by 10 m along inclined surface, the work done against frictional force is :

[$g=10 \text{ m/s}^2$]

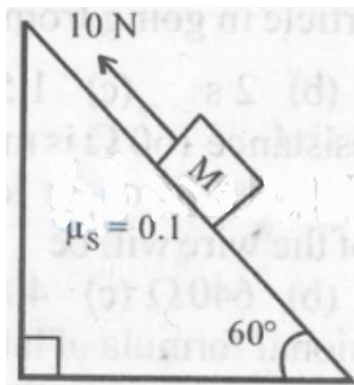

A. $5\sqrt{3} \text{ J}$

B. 5 J

C. $5 \times 10^3 \text{ J}$

D. 10 J

Ans. B

Solution:

Mass of block, $m = 1 \text{ kg}$

Force of parallel inclined surface, $F = 10 \text{ N}$

Work done against frictional force

$$= \mu_2 N \times 10 = \mu Mg \cos 60 \times 10 = 0.1 \times 5 \times 10 = 5 \text{ J}$$

13. A person of mass 60 kg is inside a lift of mass 940 kg and presses the button on control panel. The lift starts moving upwards with an acceleration 1.0 m/s^2 . If $g = 10 \text{ ms}^{-2}$, the tension in the supporting cable is

- A. 8600 N
- B. 9680 N
- C. 11000 N
- D. 1200 N

Ans. C

Solution:

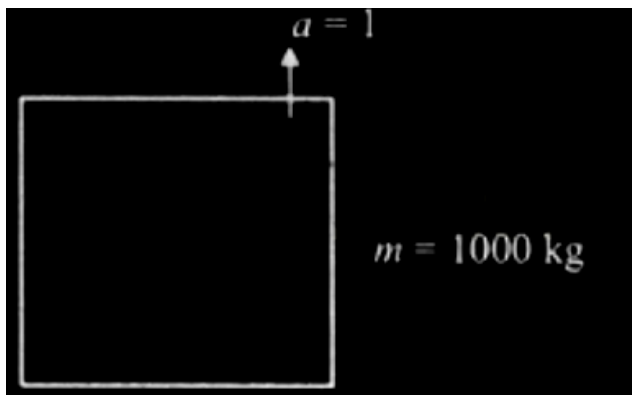

$$\text{Total mass} = (60 + 940)\text{kg} = 1000 \text{ kg}$$

Let T be the tension in the supporting cable, then

$$T - 1000g = 1000 \times 1$$

$$\Rightarrow T = 1000 \times 11 = 11000 \text{ N}$$

14. A force of $F = 0.5 \text{ N}$ is applied on lower block as shown in figure. The work done by lower block on upper block for a displacement of 3 m of the upper block with respect to ground is (Take, $g = 10 \text{ m/s}^2$)

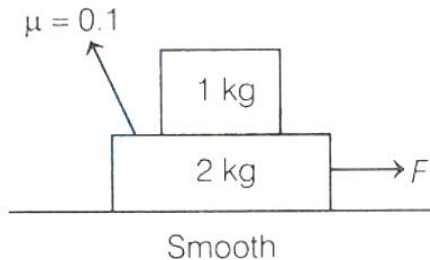

A. -0.5 J

B. 0.5 J

C. 2 J

D. -2 J

Ans. B

Solution:

Maximum acceleration of 1 kg block may be

$$a_{\text{max}} = \mu g = 1 \text{ m/s}^2$$

Common acceleration without relative motion between two blocks may be,

$$a = \frac{0.5}{3} \text{ m/s}^2$$

Since, $a < a_{\text{max}}$

There will be no relative motion and blocks will move with acceleration $\frac{0.5}{3} \text{ m/s}^2$.

Force of friction by lower block on upper block,

$$f = ma = (1) \left(\frac{0.5}{3} \right) = \frac{1}{6} \text{ N (towards right)}$$

$$\begin{aligned} \therefore W &= f \times s \\ &= \frac{1}{6} \times 3 = 0.5 \text{ J} \end{aligned}$$

15. A pendulum of mass 1 kg and length $l = 1 \text{ m}$ is released from rest at angle $\theta = 60^\circ$. The power delivered by all the forces acting on the bob at angle $\theta = 30^\circ$ will be (Take, $g = 10 \text{ m/s}^2$)

- A. 13.4 W
- B. 20.4 W
- C. 24.6 W
- D. zero

Ans. A

Solution:

Power of tension = 0

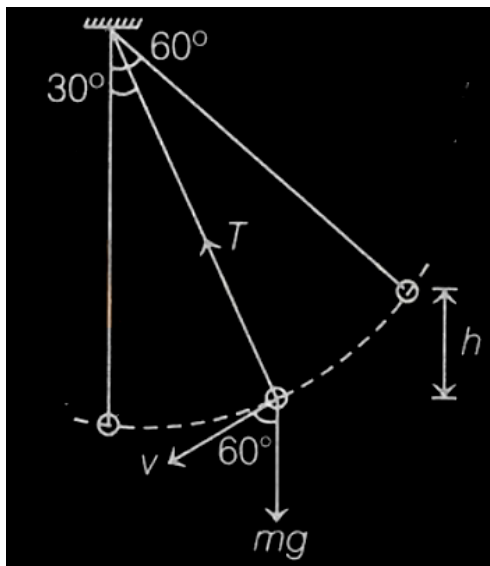

$$\text{Power of } mg = (mg)(v) \cos 60^\circ$$

$$\text{Here, } v = \sqrt{2gh}$$

$$\text{and } h = l(\cos 30^\circ - \cos 60^\circ) = 0.36 \text{ m}$$

$$v = \sqrt{2 \times 10 \times 0.36}$$

$$= 2.68 \text{ m/s}$$

$$\text{Power} = (mg)(v) \cos 60^\circ$$

$$= (1 \times 10)(2.68) \times \frac{1}{2}$$

$$= 1.34 \times 10 = 13.4 \text{ W}$$

16. An ideal massless spring S can be compressed 1 m by a force of 100 N in equilibrium. The same spring is placed at the bottom of a frictionless inclined plane inclined at 30° to the horizontal. A 10 kg block M is released from rest at the top of the incline and is brought to rest momentarily after compressing the spring by 2 m. If $g = 10 \text{ m/s}^2$, what is the speed of mass just before it touches the spring?

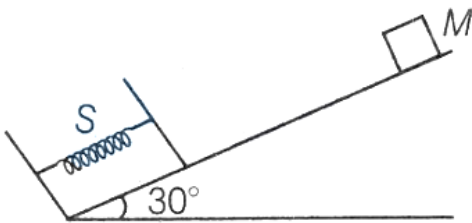

A. $\sqrt{20} \text{ m/s}$

B. $\sqrt{30} \text{ m/s}$

C. $\sqrt{10} \text{ m/s}$

D. $\sqrt{40} \text{ m/s}$

Ans. A

Solution:

$$F = kx$$

$$\therefore k = \frac{F}{x} = \frac{100}{1} \text{ N/m} = 100 \text{ N/m}$$

Now, from energy conservation, between natural length of spring and its maximum compression state.

$$\frac{1}{2}mv^2 + mgh = \frac{1}{2}kx_{\max}^2$$

$$\begin{aligned} \therefore v &= \sqrt{\frac{kx_{\max}^2}{m} - 2gh} \\ &= \sqrt{\frac{(100)(2)^2}{10} - (2)(10)\left(\frac{2}{2}\right)} = \sqrt{20} \text{ m/s} \end{aligned}$$

17. A spherical ball of mass 20 kg is stationary at the top of a hill of height 100 m . It rolls down a smooth surface to the ground, then climbs up another hill of height 30 m and finally rolls down to a horizontal base at a height of 20 m above the ground. The velocity attained by the ball is

- A. 20 m/s
- B. 40 m/s
- C. $10\sqrt{30}$ m/s
- D. 10 m/s

Ans. B

Solution:

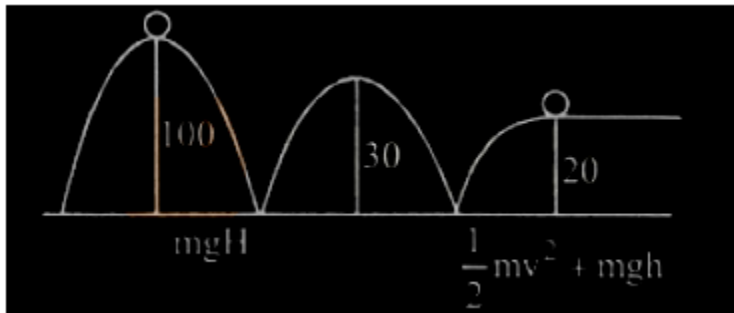

Using conservation of energy,

$$m(10 \times 100) = m\left(\frac{1}{2}v^2 + 10 \times 20\right)$$

$$\text{or } \frac{1}{2}v^2 = 800 \text{ or } v = \sqrt{1600} = 40 \text{ m/s}$$

18. A particle of mass 2 kg is on a smooth horizontal table and moves in a circular path of radius 0.6 m . The height of the table from the ground is 0.8 m. If the angular speed of the particle is 12rads^{-1} , the magnitude of its angular momentum about a point on the ground right under the centre of the circle is

- A. $14.4 \text{ kg m}^2 \text{ s}^{-1}$
- B. $8.64 \text{ kg m}^2 \text{ s}^{-1}$
- C. $20.16 \text{ kg m}^2 \text{ s}^{-1}$
- D. $11.52 \text{ kg m}^2 \text{ s}^{-1}$

Ans. A

Solution:

Angular momentum

$$L_0 = mvr \sin 90^\circ$$

$$= 2 \times 0.6 \times 12 \times 1 \times 1$$

$$[\text{As } V = r\omega, \sin 90^\circ = 1]$$

$$\text{So, } L_0 = 14.4 \text{ kgm}^2/\text{s}$$

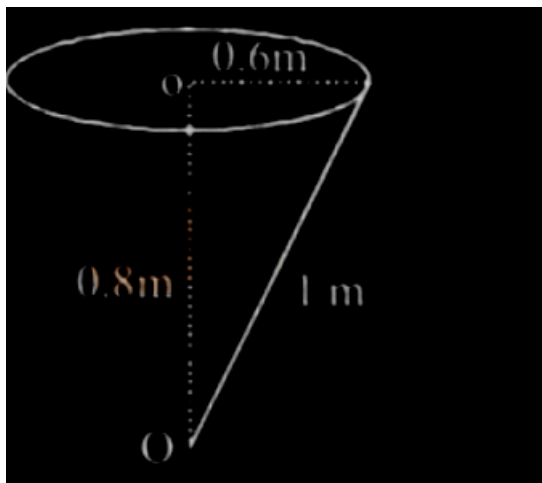

19. A ball falling freely from a height of 4.9 m/s, hits a horizontal surface. If $e = 3/4$, then the ball will hit the surface, second time after

- A. 1.0 s
- B. 1.5 s
- C. 2.0 s
- D. 3.0 s

Ans. B

Solution:

$$\begin{aligned}\text{Velocity on hitting the surface} &= \sqrt{2 \times 9.8 \times 4.9} \\ &= 9.8 \text{ m/s}\end{aligned}$$

$$\text{Velocity after first bounce, } v = \frac{3}{4} \times 9.8$$

Time taken from first bounce to the second bounce

$$= \frac{2v}{g} = 2 \times \frac{3}{4} \times 9.8 \times \frac{1}{9.8} = 1.5 \text{ s}$$

20. Two bodies of mass 1 kg and 3 kg have position vectors $\hat{i} + 2\hat{j} + \hat{k}$ and $-3\hat{i} - 2\hat{j} + \hat{k}$ respectively. The magnitude of position vector of centre of mass of this system will be similar to the magnitude of vector :

A. $\hat{i} - 2\hat{j} + \hat{k}$

B. $-3\hat{i} - 2\hat{j} + \hat{k}$

C. $-2\hat{i} + 2\hat{k}$

D. $-2\hat{i} - \hat{j} + 2\hat{k}$

Ans. A

Solution:

Position of COM of a mass - system is given as,

$$\vec{r}_{\text{com}} = \frac{m_1\vec{r}_1 + m_2\vec{r}_2}{m_1 + m_2} = \frac{1(\hat{i} + 2\hat{j} + \hat{k}) + 3(-3\hat{i} - 2\hat{j} + \hat{k})}{1 + 3}$$

$$= -2\hat{i} - \hat{j} + \hat{k}$$

$$|\vec{r}_{\text{cm}}| = | -2\hat{i} - \hat{j} + \hat{k} | = \sqrt{(2)^2 + (1)^2 + (1)^2} = \sqrt{6}$$

Only option (1) magnitude is

$$\sqrt{1^2 + (-2)^2 + 1^2} = \sqrt{6}$$

So option (1) is correct.

21. The moment of inertia of a cube of mass m and side a about one of its edges is equal to

- A. $\frac{2}{3} ma^2$
- B. $\frac{4}{3} ma^2$
- C. $3 ma^2$
- D. $\frac{8}{3} ma^2$

Ans. A

Solution:

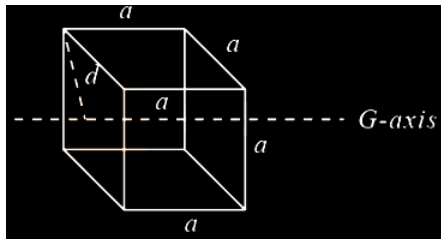

From theorem of perpendicular axes, we have

$$\begin{aligned}
 I &= I_C + m \left(\frac{a}{\sqrt{2}} \right)^2 \\
 &= \left[\frac{ma^2}{12} + \frac{ma^2}{12} \right] + \frac{ma^2}{2} \\
 &= \frac{2}{3} ma^2
 \end{aligned}$$

22. A body which is initially at rest at a height R above the surface of the Earth of radius R , falls freely towards the Earth, then its velocity on reaching the surface of the Earth is

- A. $\sqrt{(2gR)}$
- B. $\sqrt{(gR)}$
- C. $\sqrt{\frac{3}{2}gR}$
- D. $\sqrt{(4gR)}$

Ans. B

Solution:

Increase in kinetic energy = Decrease in potential energy

$$\therefore \frac{1}{2}mv^2 = \frac{mgR}{1 + \frac{R}{R}} = \frac{mgR}{2} \quad \left(\Delta U = \frac{mgh}{1 + \frac{h}{R}}, h = R \right)$$

$$\Rightarrow mv^2 = mgR \Rightarrow v = \sqrt{gR}$$

23. The distance between Sun and Earth is R . The duration of year if the distance between Sun and Earth becomes $3R$ will be:

- A. $\sqrt{3}$ years
- B. 3 years
- C. 9 years
- D. $3\sqrt{3}$ years

Ans. D

Solution:

Basically 1 year is equal to time period of earth revolution around sun.

$$\text{So, } T_1 = 1 \text{ year}$$

Now,

$$T^2 \propto R^3$$

$$\therefore \left(\frac{T_2}{T_1} \right)^2 = \left(\frac{R_2}{R_1} \right)^3$$

$$\Rightarrow T_2 = \left(\frac{R_2}{R_1} \right)^{3/2} T_1 = \left(\frac{3R}{R} \right)^{3/2} \times 1$$

$$= 3\sqrt{3} \text{ years.}$$

24. For a particle inside a uniform spherical shell, the gravitational force on the particle is

- A. infinite
- B. zero

C. $\frac{-Gm_1m_2}{r^2}$

D. $\frac{Gm_1 m_2}{r^2}$

Ans. B

Solution:

Various regions of spherical shell attract the point mass inside it in various directions. These forces cancel each other completely. Therefore the gravitational force on the particle is zero.

25. The kinetic energy of a satellite in its orbit around the earth is E . What should be the kinetic energy of the satellite so as to enable it to escape from the gravitational pull of the earth?

A. $4E$

B. $2E$

C. $\sqrt{2}E$

D. E

Ans. B

Solution:

We know that $v_e = \sqrt{2}v_0$, where v_0 is orbital velocity.

$$\text{K.E. in the orbit, } E = \frac{1}{2} M v_0^2$$

$$\text{K.E. to escape } E = \frac{1}{2} M v_e^2 = \frac{1}{2} M (2v_0^2)$$

$$= \frac{1}{2} M v_0^2 \times 2 = 2E$$

26. Two wires of the same material (Young's modulus = Y) and same length L but radii R and $2R$ respectively, are joined end to end and a weight w is suspended from the combination as shown in the figure. The elastic potential energy in the system is

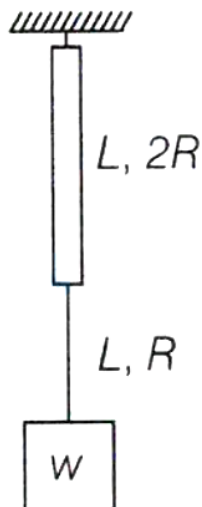

A. $\frac{3w^2 L}{4\pi R^2 Y}$

B. $\frac{3w^2 L}{8\pi R^2 Y}$

C. $\frac{5w^2 L}{8\pi R^2 Y}$

D. $\frac{w^2 L}{\pi R^2 Y}$

Ans. C

Solution:

$$\begin{aligned} \Delta l_1 &= \frac{wL}{(4\pi R^2)Y}, \Delta l_2 = \frac{wL}{\pi R^2 Y} \\ \therefore U &= \frac{1}{2} K_1 (\Delta l_1)^2 + \frac{1}{2} K_2 (\Delta l_2)^2 \\ &= \frac{1}{2} \times \frac{Y(4\pi R^2)}{L} \times \left[\frac{wL}{4\pi R^2 Y} \right]^2 + \frac{1}{2} \times \frac{Y(\pi R^2)}{L} \\ &\quad \times \left[\frac{wL}{\pi R^2 Y} \right]^2 \left(\because K = \frac{YA}{L} \right) \\ &= \frac{5w^2 L}{8\pi R^2 Y} \end{aligned}$$

27. With rise in temperature, the Young's modulus of elasticity:

A. changes erratically

B. decreases

- C. increases
- D. remains unchanged

Ans. B

Solution:

$$\text{Young's modulus, } Y = \frac{\text{Stress}}{\text{Strain}}$$

If the temperature increases, strain also increases. Hence young's modulus decreases.

28. Young's modulus of materials of a wire of Length ' L ' and cross-sectional area A is Y. If the length of the wire is doubled and cross-sectional area is halved then Young's modulus will be:

- A. Y/4
- B. 4Y
- C. Y
- D. 2 Y

Ans. C

Solution:

Young's modulus depends on the material not depends on length and cross sectional area. So Young's modulus remains constant.

29. Pressure inside two soap bubbles are 1.01 and 1.02 atmosphere, respectively. The ratio of their volumes is:

- A. 4:1
- B. 0.8:1
- C. 8:1
- D. 2:1

Ans. C

Solution:

According to question, pressure inside, 1st soap bubble,

$$\Delta P_1 = P_1 - P_0 = 0.01 = \frac{4T}{R_1} \dots(i)$$

$$\text{And } \Delta P_2 = P_2 - P_0 = 0.02 = \frac{4T}{R_2} \dots(ii)$$

Dividing, equation (ii) by (i),

$$\frac{1}{2} = \frac{R_2}{R_1} \Rightarrow R_1 = 2R_2$$

$$\text{Volume } V = \frac{4}{3}\pi R^3 \Rightarrow \frac{V_1}{V_2} = \frac{R_1^3}{R_2^3} = \frac{8R_2^3}{R_2^3} = \frac{8}{1}$$

30. A cube of ice floats partly in water and partly in kerosene oil. The ratio of volume of ice immersed in water to that in kerosene oil (specific gravity of Kerosene oil = 0.8, specific gravity of ice = 0.9)

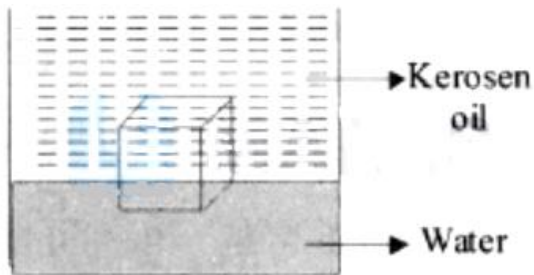

A. 8:9

B. 5:4

C. 9:10

D. 1:1

Ans. D

Solution:

Let V_1 be, the volume immersed in water.

V_2 be the volume immersed in oil.

In equilibrium condition,

$$v_1 \rho_w g + v_2 \rho_0 g = (v_1 + v_2) \rho_e g$$

$$v_1 + \frac{v_2 \rho_0}{\rho_w} = (v_1 + v_2) \frac{\rho_c}{\rho_w}$$

$$\Rightarrow v_1 + 0.8v_2 = 0.9v_1 + 0.9v_2 \Rightarrow 0.1v_1 = 0.1v_2$$

$$\Rightarrow v_1 : v_2 = 1 : 1$$

31. A solid metallic cube having total surface area 24 m^2 is uniformly heated. If its temperature is increased by 10°C , calculate the increase in volume of the cube.

(Given: $\alpha = 5.0 \times 10^{-4} \text{ C}^{-1}$)

A. $2.4 \times 10^6 \text{ cm}^3$

B. $1.2 \times 10^5 \text{ cm}^3$

C. $6.0 \times 10^4 \text{ cm}^3$

D. $4.8 \times 10^5 \text{ cm}^3$

Ans. B

Solution:

We have $\Delta V = V_0 \gamma \Delta T$

$$\Delta V = a^3, (3\alpha)\Delta T$$

Now, $6a^2 = 24$ [\because Total surface area of cube = $6a^2$]

$$\Rightarrow a^2 = 4 \Rightarrow a = 2$$

$$\text{So, } \Delta V = 2^3 (3 \times 5 \times 10^{-4}) \times 10 = 1200 \times 10^{-4} \text{ m}^3$$

$$= 1200 \times 10^2 \text{ cm}^3 = 1.2 \times 10^5 \text{ cm}^3$$

32. In the given cycle ABCDA, the heat required for an ideal monoatomic gas will be

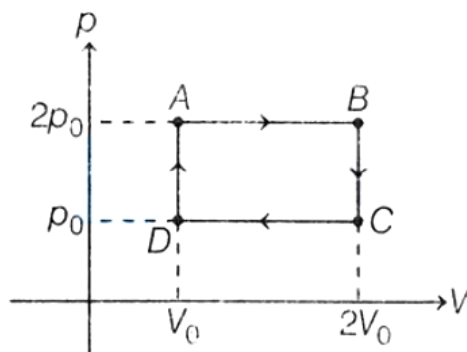

- A. p_0V_0
- B. $13/2 p_0V_0$
- C. $11/2 p_0V_0$
- D. $4 p_0V_0$

Ans. B

Solution:

In the given cycle, heat is supplied in process D to A at constant volume and in process A to B at constant pressure.

$$\therefore \text{Heat supplied, } Q = nC_V(\Delta T)_{DA} + nC_p(\Delta T)_{AB}$$

For an ideal monoatomic gas,

$$\begin{aligned} C_V &= \frac{3}{2}R \text{ and } C_p = \frac{5}{2}R \\ \Rightarrow Q &= \frac{3}{2}nR\Delta T + \frac{5}{2}nR\Delta T \quad [\because nR\Delta T = p\Delta V] \\ &= \frac{3}{2}(p_0V_0) + 5(p_0V_0) \\ &= \frac{13}{2}p_0V_0 \end{aligned}$$

33. A gas can be taken from A to B via two different processes ACB and ADB. When path ACB is used 60 J of heat flows into the system and 30J of work is done by the system. If path ADB is used work done by the system is 10 J. The heat Flow into the system in path ADB is :

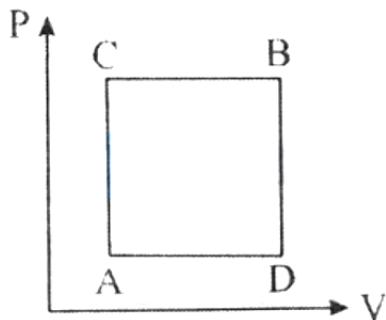

- A. 40 J
- B. 80 J
- C. 100 J
- D. 20 J

Ans. A

Solution:

ΔU remains same for both paths ACB and ADB

$$\Delta Q_{ACB} = \Delta W_{ACB} + \Delta U_{ACB}$$

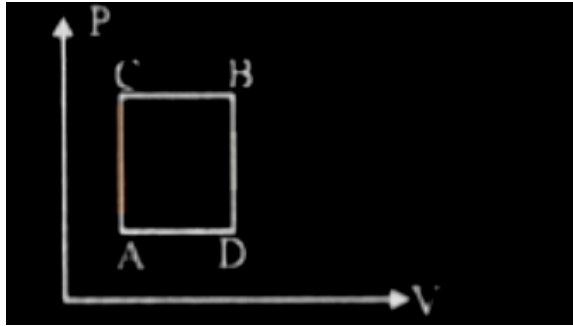

$$\Rightarrow 60 \text{ J} = 30 \text{ J} + \Delta U_{ACB} \Rightarrow \Delta U_{ACB} = 30 \text{ J}$$

As change in internal energy depends only on initial and final point

$$\therefore \Delta U_{ADB} = \Delta U_{ACB} = 30 \text{ J}$$

$$\Delta Q_{ADB} = \Delta U_{ADB} + \Delta W_{ADB} = 10 \text{ J} + 30 \text{ J} = 40 \text{ J}$$

34. A source supplies heat to a system at the rate of 1000 W. If the system performs work at a rate of 200 W. The rate at which internal energy of the system increases

- A. 1200 W
- B. 600 W
- C. 500 W
- D. 800 W

Ans. D

Solution:

Given,

Rate of heat supplied, $\frac{dQ}{dt} = 1000 \text{ W}$

Rate of work performed, $\frac{dw}{dt} = 200 \text{ W}$

Using first law of thermodynamics

$$dQ = dU + dw$$

$$\Rightarrow \frac{dU}{dt} = \frac{dQ}{dt} - \frac{dw}{dt} \Rightarrow \frac{dU}{dt} = 1000 - 200 = 800$$

35. On celcius scale the temperature of body increases by 40°C . The increase in temperature on Fahrenheit scale is:

A. 70°F

B. 68°F

C. 72°F

D. 75°F

Ans. C

Solution:

$$\text{Since } \frac{F-32}{9} = \frac{C}{5}$$

$$\Rightarrow \Delta C = \frac{5}{9} \Delta F$$

$$\Rightarrow 40 = \frac{5}{9} \Delta F \Rightarrow \Delta F = 72^\circ\text{F}$$

36. In a mixture of gases, the average number of degree of freedoms per molecule is 6 . The rms speed of the molecule of the gas is c , then the velocity of sound in the gas is

A. $c/\sqrt{3}$

B. $c/\sqrt{2}$

C. $2c/3$

D. $3c/3$

Ans. C

Solution:

$$(v_{\text{rms}} = \sqrt{\frac{3RT}{M}} \text{ and } v_{\text{sound}} = \sqrt{\frac{\gamma RT}{M}} \frac{v_{\text{sound}}}{v_{\text{rms}}} = \sqrt{\frac{\gamma}{3}}$$

Degree of freedom is 6 .

$$\therefore \gamma = 1 + \frac{2}{f} = 1 + \frac{2}{6} = \frac{4}{3}$$

$$\therefore v_{\text{sound}} = \sqrt{\frac{4/3}{3}} v_{\text{rms}} = \frac{2}{3} v_{\text{rms}} = \frac{2c}{3}$$

37. The temperature of an ideal gas is increased from 200 K to 800 K . If r.m.s. speed of gas at 200 K is v_0 . Then, r.m.s. speed of the gas at 800 K will be:

- A. v_0
- B. $4v_0$
- C. $v_0/4$
- D. $2v_0$

Ans. D

Solution:

RMS speed,

$$V_{\text{rms}} = \sqrt{\frac{3RT}{M}}$$

$$\Rightarrow V_{\text{rms}} \propto \sqrt{T}$$

Here, $T_{\text{initial}} = 200 \text{ K}$

$T_{\text{final}} = 800 \text{ K}$

Initial RMS speed = v_0

$$\therefore \frac{v_0}{v_{\text{rms}}} = \sqrt{\frac{200}{800}} \Rightarrow v_{\text{rms}} = 2v_0$$

38. Two vessels A and B are of the same size and are at same temperature. A contains 1 g of hydrogen and B contains 1 g of oxygen. P_A and P_B are the pressures of the gases in A and B respectively, then P_A/P_B is:

- A. 8
- B. 16

C. 32

D. 4

Ans. B

Solution:

$$n_A = \frac{1}{2} \text{ mol}, n_B = \frac{1}{32} \text{ mol}$$

By ideal gas equation,

$$PV = nRT \Rightarrow P \propto n$$

$$\therefore \frac{P_A}{P_B} = \frac{n_A}{n_B} = \frac{32}{2} = 16$$

39. Five identical springs are used in the three configurations as shown in figure. The time periods of vertical oscillations in configurations (a), (b) and (c) are in the ratio.

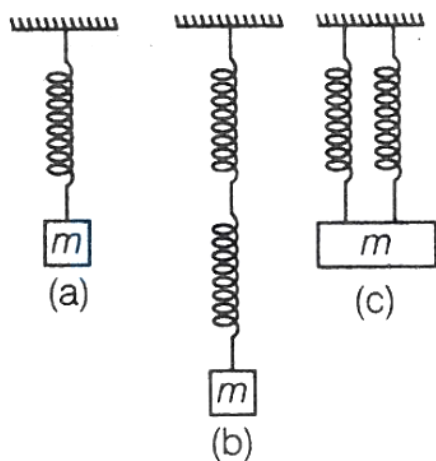

A. $1 : \sqrt{2} : \frac{1}{\sqrt{2}}$

B. $2 : \sqrt{2} : \frac{1}{\sqrt{2}}$

C. $\frac{1}{\sqrt{2}} : 2 : 1$

D. $2 : \frac{1}{\sqrt{2}} : 1$

Ans. A

Solution:

$$T_a = 2\pi\sqrt{\frac{m}{k}}$$

$$T_b = 2\pi\sqrt{\frac{m}{(k/2)}}$$

$$T_c = 2\pi\sqrt{\frac{m}{2k}}$$

$$\therefore T_a : T_b : T_c = 1 : \sqrt{2} : \frac{1}{\sqrt{2}}$$

40. A particle executes simple harmonic motion between $x = -A$ and $x = +A$. If time taken by particle to go from $x = 0$ to $A/2$ is 2s; then time taken by particle in going from $x = A/2$ to A is:

- A. 3 s
- B. 2 s
- C. 1.5 s
- D. 4 s

Ans. D

Solution:

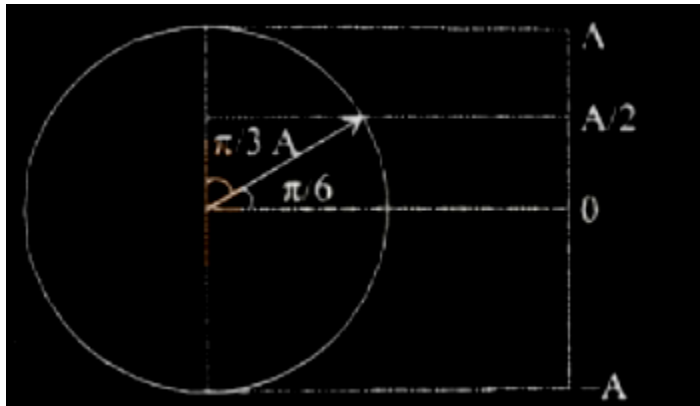

Let time from 0 to $A/2$ is t_1 and from $A/2$ to A is t_2 From the standard equation of SHM,

$$\Rightarrow \frac{A}{2} = A \sin(\omega t_1)$$

$$\Rightarrow \omega t_1 = \sin^{-1}\left(\frac{1}{2}\right) = \frac{\pi}{6} \dots(i)$$

Using $x = A_0 \sin \omega t$ again

$$A = A \sin \omega (t_1 + t_2)$$

$$\omega (t_1 + t_2) = \sin^{-1}(1) = \frac{\pi}{2}$$

Using (i)

$$\omega t_2 = \frac{\pi}{2} - \frac{\pi}{6} = \frac{\pi}{3} \dots(ii)$$

Dividing equation (i) by (ii) we get

$$\frac{t_1}{t_2} = \frac{1}{2}$$

$$\Rightarrow t_2 = 2t_1 = 2 \times 2 = 4\text{sec}$$

41. A simple pendulum doing small oscillations at a place R height above earth surface has time period of $T_1 = 4$ s. T_2 would be it's time period if it is brought to a point which is at a height $2R$ from earth surface. Choose the correct relation [R = radius of Earth]:

A. $T_1 = T_2$

B. $2 T_1 = 3 T_2$

C. $3 T_1 = 2 T_2$

D. $2 T_1 = T_2$

Ans. C

Solution:

Time period of simple pendulum,

$$T = 2\pi\sqrt{\frac{l}{g}} \text{ \& } g = \frac{GM}{(R+h)^2}$$

$$\therefore T \propto (R+h)$$

$$\Rightarrow \frac{T_1}{T_2} = \frac{(R+h_1)}{(R+h_2)} = \frac{(R+R)}{(R+2R)} = \frac{2}{3} \Rightarrow 3 T_1 = 2 T_2$$

42. The speed of sound in oxygen at S.T.P. will be approximately:

(Given, $R = 8.3\text{JK}^{-1}$, $\gamma = 1.4$)

A. 315 m/s

B. 333 m/s

C. 341 m/s

D. 325 m/s

Ans. A

Solution:

At STP

Temperature, $T = 273\text{ K}$

Molecular mass of oxygen, $M = 32 \times 10^{-3}\text{ kg}$

Speed of sound is given by

$$v = \sqrt{\frac{\gamma RT}{M}} = \sqrt{\frac{1.4 \times 8.3 \times 273}{32 \times 10^{-3}}}$$

$$= 314.8541 \simeq 315\text{ m/s}$$

43. A plane progressive wave is given by $y = 2 \cos 2\pi(330t - x)\text{m}$. The frequency of the wave is:

A. 165 Hz

B. 330 Hz

C. 660 Hz

D. 340 Hz

Ans. B

Solution:

Equation of wave is, $y = 2 \cos 2\pi(330t - x)$ m

$$y = A \cos(\omega t - kx)$$

On comparing $\omega = 2\pi \times 330$

$$2\pi f = 2\pi \times 330 \Rightarrow f = 330 \text{ Hz}$$

$$[\because \omega = 2\pi F]$$

44. An oil drop of radius $1\mu\text{ m}$ is held stationary under a constant electric field of $3.65 \times 10^4 \text{ N/C}$ due to some excess electrons presence on it. If the density of oil drop is 1.26 g/cm^3 , then number of excess electrons on the oil drop approximately are

[Take, $g = 10 \text{ ms}^{-2}$]

A. 7

B. 12

C. 9

D. 8

Ans. C

Solution:

$$E = 3.65 \times 10^4 \text{ N/C}, r = 1\mu \text{ m} = 10^{-6} \text{ m}$$

$$\begin{aligned}\rho_{\text{oil}} &= 1.26 \text{ g/cm}^3 \\ &= 1.26 \times 10^3 \text{ kg/m}^3\end{aligned}$$

Since, droplet is stationary hence weight of droplet = force due to electric field

$$\Rightarrow \frac{4}{3}\pi r^3 \cdot \rho_{\text{oil}} \cdot g = qE \dots (i)$$

If n be the number of excess electrons in the oil drop, then

$$q = ne$$

$$\text{Hence, from Eq. (i), } \frac{4}{3}\pi r^3 \rho_{\text{oil}} \cdot g = neE$$

$$\begin{aligned}\Rightarrow n &= \frac{4\pi r^3 \rho_{\text{oil}} g}{3eE} \\ &= \frac{4 \times 3.14 \times (10^{-6})^3 \times 1.26 \times 10^3 \times 10}{3 \times 1.6 \times 10^{-19} \times 3.65 \times 10^4} \\ &= 9.03 \simeq 9\end{aligned}$$

45. The potential of a large liquid drop when eight liquid drops are combined is 20 V, then the potential of each single drop was

- A. 10 V
- B. 7.5 V
- C. 5 V
- D. 2.5 V

Ans. C

Solution:

Volume of eight drops = Volume of a big drop

$$\therefore \left(\frac{4}{3}\pi r^3\right) \times 8 = \frac{4}{3}\pi R^3$$

$$\Rightarrow 2r = R \dots (i)$$

According to charge conservation,

$$8q = Q \dots (ii)$$

$$\text{Potential of one small drop, } V' = \frac{q}{4\pi\epsilon_0 r}$$

$$\text{Similarly, potential of big drop, } V = \frac{Q}{4\pi\epsilon_0 R}$$

$$\text{Now, } \frac{V'}{V} = \frac{q}{Q} \times \frac{R}{r}$$

$$\Rightarrow \frac{V'}{20} = \frac{q}{8q} \times \frac{2r}{r} \quad [\text{from Eqs. (i) and (ii)}]$$

$$\therefore V' = 5 \text{ V}$$

46. A dust particle of mass 4×10^{-12} mg is suspended in air under the influence of an electric field of 50 N/C directed vertically upwards. How many electrons were removed from the neutral dust particle? [Take, $g = 10 \text{ m/s}^2$]

A. 15

B. 8

C. 5

D. 4

Ans. C

Solution:

Mass of dust particle, $m = 4 \times 10^{-12}$ mg

$$\begin{aligned}
&= 4 \times 10^{-12} \times 10^{-3} \text{ g} \\
&= 4 \times 10^{-12} \times 10^{-3} \times 10^{-3} \text{ kg} \\
&= 4 \times 10^{-18} \text{ kg}
\end{aligned}$$

Electric field, $E = 50 \text{ N/C}$

Weight of dust particle, $W = mg$

$$= 4 \times 10^{-18} \times 10 = 4 \times 10^{-17} \text{ N}$$

Electric force experienced by dust particle,

$$F_e = qE$$

$$F_e = ne \cdot E = n \times 1.6 \times 10^{-19} \times 50$$

where, n is the number of electrons removed from neutral dust particle.

∴ At balance condition,

Electric force = Weight of dust particle

$$n \times 1.6 \times 10^{-19} \times 50 = 4 \times 10^{-17}$$

$$\begin{aligned}
n &= \frac{4 \times 10^{-17}}{1.6 \times 10^{-19} \times 50} \\
&= \frac{400}{80} = 5
\end{aligned}$$

47. Electric field at point (30,30,0) due to a charge of $0.008\mu\text{C}$ placed at origin will be, (coordinates are in cm)

A. $8000\text{NC}^{-1} - 18000\text{NC}^{-1}$

B. $4000(\hat{i} + \hat{j})\text{NC}^{-1}$

C. $200\sqrt{2}(\hat{i} + \hat{j})\text{NC}^{-1}$

D. $400\sqrt{2}(\hat{i} + \hat{j})\text{NC}^{-1}$

Ans. C

Solution:

$$E = \frac{Kq}{r^2} \cdot \hat{r} = \frac{Kq}{r^3} \cdot \mathbf{r}$$

Here,

$$\begin{aligned} r &= \sqrt{(x_2 - x_1)^2 + (y_2 - y_1)^2 + (z_2 - z_1)^2} \\ &= \sqrt{(30)^2 + (30)^2 + 0^2} \\ &= 30\sqrt{2} \text{ cm} \\ &= 30\sqrt{2} \times 10^{-2} \text{ m} \end{aligned}$$

and $q = 8 \times 10^{-3} \times 10^{-6} \text{ C}$

Also, $\mathbf{r} = (30\hat{\mathbf{i}} + 30\hat{\mathbf{j}}) \times 10^{-2} \text{ m}$

$$\begin{aligned} \text{So, } E &= \frac{9 \times 10^9 \times 8 \times 10^{-3} \times 10^{-6}}{(30\sqrt{2} \times 10^{-2})^3} \times (30\hat{\mathbf{i}} + 30\hat{\mathbf{j}}) \times 10^{-2} \\ &= \frac{9 \times 8 \times 10^9 \times 10^{-11}}{27 \times 2\sqrt{2} \times 10^{-6} \times 10^3} \times 30(\hat{\mathbf{i}} + \hat{\mathbf{j}}) \\ &= \frac{9 \times 8 \times 10^2 \times 3}{27 \times 2\sqrt{2}} (\hat{\mathbf{i}} + \hat{\mathbf{j}}) \\ &= 200\sqrt{2}(\hat{\mathbf{i}} + \hat{\mathbf{j}}) \text{ NC}^{-1} \end{aligned}$$

48. If two charges q_1 and q_2 are separated with distance 'd' and placed in a medium of dielectric constant K. What will be the equivalent distance between charges in air for the same electrostatic force?

- A. $d\sqrt{K}$
- B. $K\sqrt{d}$
- C. $1.5d\sqrt{K}$
- D. $2d\sqrt{K}$

Ans. A

As. $F(\text{air}) = F(\text{medium})$

$$\Rightarrow \frac{1}{4\pi\epsilon_0} \frac{q_1 q_2}{d_{\text{air}}^2} = \frac{1}{K} \frac{1}{4\pi\epsilon_0} \frac{q_1 q_2}{d^2} \Rightarrow d_{\text{air}} = d\sqrt{K}$$

49. Electric potential at a point 'P' due to a point charge of $5 \times 10^{-9} \text{ C}$ is 50 V. The distance of 'P' from the point charge is:

(Assume, $1/4\pi\epsilon_0 = 9 \times 10^9 \text{ Nm}^2\text{C}^{-2}$)

- A. 3 cm
- B. 9 cm
- C. 90 cm
- D. 0.9 cm

Ans. C

Solution:

Electric potential at a point P due to a point charge, ($\because K = 9 \times 10^9$)

$$V_P = \frac{KQ}{r}$$

$$\Rightarrow 50 = \frac{9 \times 10^9 \times 5 \times 10^{-9}}{r}$$

$$\Rightarrow r = \frac{45}{50} = \frac{9}{10} = 0.9 \text{ m} = 90 \text{ cm}$$

50. Five charges $+q$, $+5q$, $-2q$, $+3q$ and $-4q$ are situated as shown in the figure, The electric flux due to this configuration through the surface S is:



- A. $5q/\epsilon_0$
- B. $4q/\epsilon_0$
- C. $3q/\epsilon_0$
- D. q/ϵ_0

Ans. B

Solution:

Using Gauss's law, $\phi = \frac{q}{\epsilon_0}$

Here, q = charge inside the closed surface

$$\therefore \phi = \frac{q+(-2q)+5q}{\epsilon_0}$$

$$\Rightarrow \phi = \frac{4q}{\epsilon_0}$$

51. A parallel plate capacitor with plate area A and plate separation $d = 2$ m has a capacitance of $4\mu\text{ F}$.

The new capacitance of the system if half of the space between them is filled with a dielectric material of dielectric constant $K = 3$ (as shown in figure) will be:

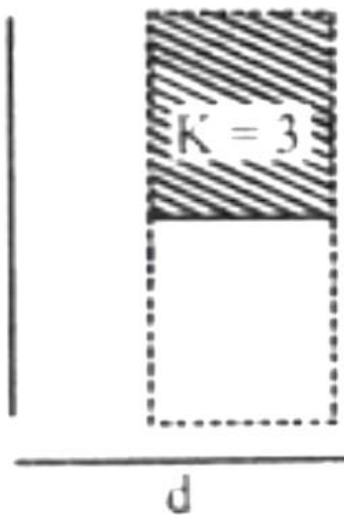

- A. $2\mu\text{ F}$
- B. $32\mu\text{ F}$
- C. $6\mu\text{ F}$
- D. $8\mu\text{ F}$

Ans. C

Solution:

We have, $C_i = \frac{A\epsilon_0}{d} = 4\mu F$

$$C_f = \frac{A\epsilon_0}{d - t + \frac{t}{k}} = \frac{A\epsilon_0}{d - \frac{d}{2} + \frac{d}{2 \times 3}}$$

$$= \frac{A\epsilon_0}{d\left(1 - \frac{1}{2} + \frac{1}{6}\right)}$$

$$= \frac{4\mu F}{\frac{2}{3}} = 6\mu F$$

52. In the given circuit, $E_1 = E_2 = E_3 = 2 \text{ V}$ and $R_1 = R_2 = 4\Omega$, then current flowing through the branch AB is

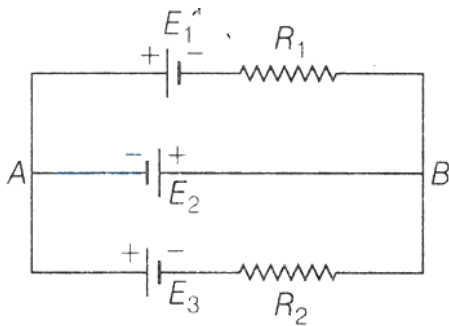

- A. zero
- B. 2A from A and B
- C. 2A from B to A
- D. 5A from B to B

Ans. B

Solution:

The given circuit can be redrawn as,

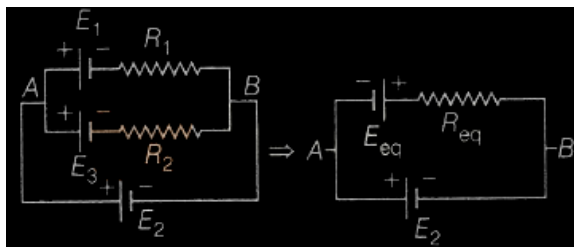

where, equivalent emf of the combination,

$$E_{eq} = \frac{E_1 R_1 + E_2 R_2}{R_1 + R_2}$$

$$= \frac{2 \times 4 + 2 \times 4}{4 + 4} = 2 \text{ V}$$

$$\text{and } R_{eq} = \frac{R_1 R_2}{R_1 + R_2} = \frac{4 \times 4}{4 + 4} = \frac{16}{8} = 2 \Omega$$

Net emf of the circuit,

$$E' = E_2 + E_{eq}$$

$$= 2 + 2$$

$$= 4 \text{ V}$$

∴ Current flowing through branch AB ,

$$I = \frac{E'}{R_{eq}} = \frac{4}{2} = 2 \text{ A}$$

Clearly from figure, it is clear that direction of current is from point A to B clockwise is loop.

53. In the following circuit diagram, when 3Ω resistor is removed, then equivalent resistance of the network

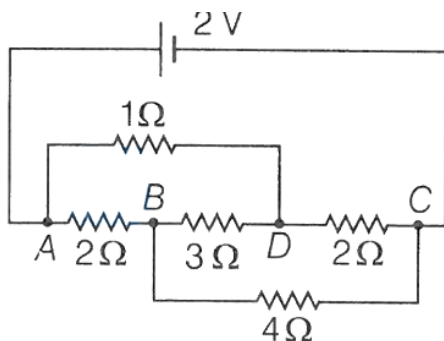

- A. increases
- B. decreases
- C. remains same
- D. None of these

Ans. C

Solution:

The equivalent Wheatstone's bridge network of the given circuit is shown in figure. Here,

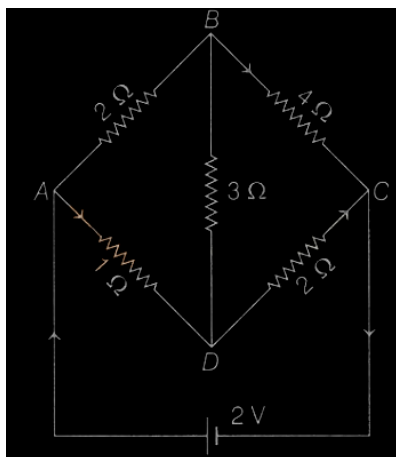

The points B and D are at the same potential as the bridge is balanced. So, the 3Ω resistance in BD arm is ineffective and can be omitted from the circuit.

Hence, equivalent resistance remains same when 3Ω resistor is removed.

54. A conducting wire is stretched by applying a deforming force, so that its diameter decreases to 40% of original value. The percentage change in its resistance will be

- A. 0.9%
- B. 0.12%
- C. 1.6%
- D. 0.5%

Ans. C

Solution:

On stretching, volume of wire remains constant.

So,

$$V = Al \text{ or } l = \frac{V}{A}$$

$$\therefore R = \rho \cdot \frac{l}{A} = \frac{\rho V}{A^2} = \frac{\rho V}{\frac{\pi^2 D^4}{16}} = \frac{16\rho V}{\pi^2 D^4}$$

$$\therefore \frac{\Delta R}{R} = -4 \frac{\Delta D}{D} = -4(-0.4) = 1.6\%$$

55. A wire of resistance 160Ω is melted and drawn in wire of one-fourth of its length. The new resistance of the wire will be

- A. 10Ω

B. 640Ω

C. 40Ω

D. 16Ω

Ans. A

Solution:

Let

$$\text{Initial length} = l_1$$

$$\text{Final length} = l_2$$

$$\text{Initial area} = A_1$$

$$\text{Final area} = A_2$$

\therefore Volume remains same

$$\therefore A_1 l_1 = A_2 l_2 \Rightarrow A_1 l_1 = A_2 \frac{l_1}{4}$$

$$\Rightarrow 4 A_1 = A_2$$

$$\text{Initial resistance, } R_1 = \frac{\rho l_1}{A_1} = 160\Omega \text{ (given)}$$

$$\text{Final resistance, } R_2 = \frac{\rho l_2}{A_2}$$

$$\therefore \frac{R_2}{R_1} = \frac{l_2 A_1}{A_2 l_1} = \frac{l_1}{4} \frac{A_1}{A_1 l_1}$$

$$\Rightarrow R_2 = \frac{1}{16} R_1 = \frac{1}{16} \times 160 = 10\Omega$$

56. Five cells each of emf E and internal resistance r send the same amount of current through an external resistance R whether the cells are connected in parallel or in series. Then the ratio (R/r) is

A. 2

B. $1/2$

C. $1/5$

D. 1

Ans. D

Solution:

Given : Number of cells, $n = 5$, emf of each cell = E

Internal resistance of each cell = r

In series, current through resistance R

$$I = \frac{nE}{nr+R} = \frac{5E}{5r+R}$$

In parallel, current through resistance R

$$I' = \frac{E}{\frac{r}{n}+R} = \frac{nE}{r+nR} = \frac{5E}{r+5R}$$

According to question, $I = I'$

$$\therefore \frac{5E}{5r+5R} = \frac{5E}{r+5R} \Rightarrow 5r + R = r + 5R$$

$$\text{or } R = r \quad \therefore \frac{R}{r} = 1$$

57. The straight wire AB carries a current I . The ends of the wire subtend angles θ_1 and θ_2 at the point P as shown in figure. The magnetic field at the point P is

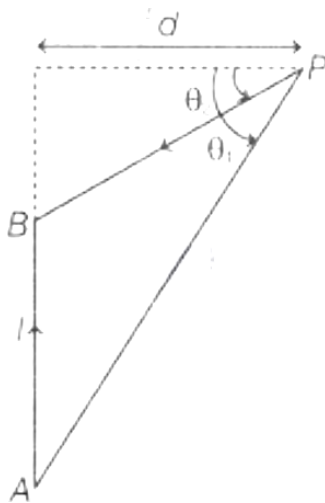

A. $\frac{\mu_0 I}{4\pi d} (\sin \theta_1 - \sin \theta_2)$

B. $\frac{\mu_0 I}{4\pi d} (\sin \theta_1 + \sin \theta_2)$

C. $\frac{\mu_0 I}{4\pi d} (\cos \theta_1 - \cos \theta_2)$

D. $\frac{\mu_0 I}{4\pi d} (\cos \theta_1 + \cos \theta_2)$

Ans. A

Solution:

The magnetic field at a point P due to a current carrying straight wire, such that the ends of the wires, makes angle α and β (see figure) is given by

$$B = \frac{\mu_0 I}{4\pi d} (\sin \alpha - \sin \beta)$$

where, d is the distance between the point P and wire.

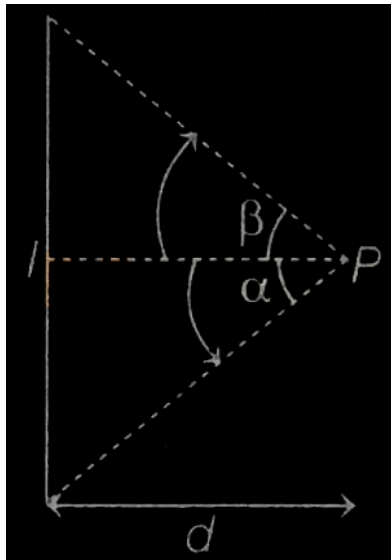

In the given problem, $\alpha = \theta_1$ and $\beta = \theta_2$

$$\therefore B = \frac{\mu_0 I}{4\pi d} (\sin \theta_1 - \sin \theta_2)$$

58. A long straight wire of radius a carries a steady current I. The current is uniformly distributed across its cross section. The ratio of the magnetic field at a/2 and 2a from axis of the wire is:

- A. 1:4
- B. 4:1
- C. 1:1
- D. 3:4

Ans. C

Solution:

Magnetic field due to straight wire,

$$B = \frac{\mu_0 I}{2\pi r}$$

Magnetic field at $\frac{a}{2}$ is,

$$B_{a/2} = \frac{\mu_0 I}{2\pi(a/2)}$$

$$\therefore \frac{B_{a/2}}{B_{2a}} = \frac{1}{1} = 1 : 1$$

59. The electrostatic force (\vec{F}_1) and magnetic force (\vec{F}_2) acting on a charge q moving with velocity v can be written:

A. $\vec{F}_1 = q\vec{V} \cdot \vec{E}, \vec{F}_2 = q(\vec{B} \cdot \vec{V})$

B. $\vec{F}_1 = q\vec{B}, \vec{F}_2 = q(\vec{B} \times \vec{V})$

C. $\vec{F}_1 = q\vec{E}, \vec{F}_2 = q(\vec{V} \times \vec{B})$

D. $\vec{F}_1 = q\vec{E}, \vec{F}_2 = q(\vec{B} \times \vec{V})$

Ans. C

Solution:

Electrostatic force, $\vec{F}_1 = q\vec{E}$

Magnetic force, $\vec{F}_2 = q(\vec{V} \times \vec{B})$

60. Inside a solenoid of radius 0.5 m, magnetic field is changing at a rate of 50×10^{-6} T/s.

Acceleration of an electron placed at a distance of 0.3 m from axis of solenoid will be

A. $23 \times 10^6 \text{ ms}^{-2}$

B. $26 \times 10^6 \text{ m/s}^2$

C. $1.3 \times 10^9 \text{ ms}^{-2}$

$$D. 26 \times 10^9 \text{ m/s}^2$$

Ans. A

Solution:

The changing magnetic field induce an electric field which will accelerate the electron.

The acceleration of electron will be

$$a = \frac{eE}{m} \quad [\because F = qE]$$

To find electric field E , we will use Faraday's electromagnetic induction.

$$\text{emf}, \varepsilon = -\frac{d\phi}{dt} (B \cdot A)$$

where, B is the magnetic field and A is the area of cross-section.

$$\varepsilon = -A \cdot \frac{dB}{dt} = -\pi r^2 \frac{dB}{dt}$$

$$\text{Now, electric field, } E = -\frac{\text{emf}}{\text{distance}} = -\frac{\varepsilon}{d}$$

$$= \frac{\pi r^2}{d} \frac{dB}{dt}$$

$$\text{Now, acceleration, } a = \frac{e}{m} \frac{\pi r^2}{d} \frac{dB}{dt}$$

$$= \frac{1.6 \times 10^{-19}}{9.1 \times 10^{-31}} \times \frac{22}{7}$$

$$\times \frac{(0.5)^2}{(0.3)} \times 50 \times 10^{-6}$$

$$= 23 \times 10^6 \text{ ms}^{-2}$$

61. There are two long co-axial solenoids of same length l . The inner and outer coils have radii r_1 and r_2 and number of turns per unit length n_1 and n_2 , respectively. The ratio of mutual inductance to the self-inductance of the inner-coil is:

A. $\frac{n_1}{n_2}$

B. $\frac{n_2}{n_1} \cdot \frac{n_1}{r_2}$

C. $\frac{n_2}{n_1} \cdot \frac{r_2^2}{r_1^2}$

D. $\frac{n_2}{n_1}$

Ans. D

Solution:

The rate of mutual inductance is given by

$$M = \mu_0 n_1 n_2 \pi r_1^2 \dots (i)$$

The rate of self inductance is given by

$$L = \mu_0 n_1^2 \pi r_1^2 \dots (ii)$$

Dividing (i) by (ii)

$$\Rightarrow \frac{M}{L} = \frac{n_2}{n_1}$$

62. A rectangular loop of length 2.5 m and width 2 m is placed at 60° to a magnetic field of 4 T . The loop is removed from the field in 10 sec. The average emf induced in the loop during this time is

- A. -2 V
- B. +2 V
- C. +1 V
- D. -1 V

Ans. C

Solution:

$$\begin{aligned} \text{Average emf, } e &= \frac{\text{Change in flux}}{\text{Time}} = -\frac{\Delta\phi}{\Delta t} \\ &= -\frac{0 - (4 \times (2.5 \times 2) \cos 60^\circ)}{10} = +1 \text{ V} \end{aligned}$$

63. Find the average value of current shown graphically from $t = 0$ to $t = 2$ s.

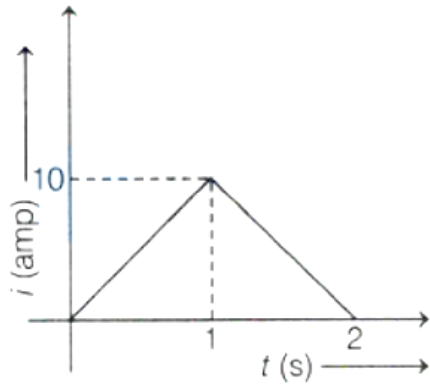

- A. 3 A
- B. 5 A
- C. 10 A
- D. 4 A

Ans. B

Solution:

From $i - t$ graph, area from $t = 0$ to $t = 2$ s, we get

$$\begin{aligned}
 &= \frac{1}{2} \times 1 \times 10 + \frac{1}{2} \times (2 - 1) \times 10 \\
 &= 5 + 5 = 10 \text{ A}
 \end{aligned}$$

$$\therefore \text{Area current, } i_{\text{av}} = \frac{\text{Area } (i - t) \text{ graph}}{\text{time interval}} = \frac{10}{2} = 5 \text{ A}$$

64. In an ac circuit, an inductor, a capacitor and a resistor are connected in series with $X_L = R = X_C$. Impedance of this circuit is:

- A. $2R^2$
- B. Zero
- C. R
- D. $R\sqrt{2}$

Ans. C

Solution:

Impedance in LCR circuit

$$Z = \sqrt{(X_L - X_C)^2 + R^2} \quad \because X_L = X_C = R$$

$$\therefore Z = R$$

65. An alternating voltage $V(t) = 220 \sin 100\pi t$ volt is applied to a purely resistive load of 50Ω . The time taken for the current to rise from half of the peak value to the peak value is:

- A. 5 ms
- B. 3.3 ms
- C. 7.2 ms
- D. 2.2 ms

Ans. B

Solution:

Rising half to peak

$$t = T/6$$

$$t = \frac{2\pi}{6\omega} = \frac{\pi}{3\omega} = \frac{\pi}{300\pi} = \frac{1}{300} = 3.3 \text{ ms}$$

$$\text{Here } \omega = 100\pi \text{ rad/s}$$

66. A parallel plate capacitor consists of two circular plates of radius $R = 0.1$ m. They are separated by a short distance. If electric field between the capacitor plates changes as $\frac{dE}{dt} = 6 \times 10^{13} \frac{\text{V}}{\text{m}\cdot\text{s}}$, then the value of displacement current is

- A. 15.25 A
- B. 6.25 A
- C. 16.67 A
- D. 4.69 A

Ans. C

Solution:

Given, area of plates, $A = \pi R^2 = 3.14 \times (0.1)^2 \text{ m}^2$ and $\frac{dE}{dt} = 6 \times 10^{13} \frac{\text{V}}{\text{m} \times \text{s}}$

Displacement current between the plates,

$$\begin{aligned} I_d &= \epsilon_0 \frac{d\phi}{dt} \\ \Rightarrow I_d &= \epsilon_0 A \left(\frac{dE}{dt} \right) \left[\because \frac{d\phi}{dt} = A \frac{dE}{dt} \right] \\ &= 8.85 \times 10^{-12} \times 3.14 \times (0.1)^2 \times 6 \times 10^{13} \\ \Rightarrow I_d &= 16.67 \text{ A} \end{aligned}$$

67. Electromagnetic waves travel in a medium with speed of $1.5 \times 10^8 \text{ ms}^{-1}$. The relative permeability of the medium is 2.0 . The relative permittivity will be :

- A. 5
- B. 1
- C. 4
- D. 2

Ans. D

Solution:

$$\begin{aligned} v &= \frac{c}{\sqrt{\mu_r \epsilon_r}} \\ \Rightarrow 1.5 \times 10^8 &= \frac{3 \times 10^8}{\sqrt{2 \times \epsilon_r}} \\ \Rightarrow 2\epsilon_r &= 4 \Rightarrow \epsilon_r = 2 \end{aligned}$$

68. Power of biconvex lens is P diopter. When it is cut into two symmetrical halves by a plane containing the principal axis. The ratio of power of two halves is

- A. 1:2
- B. 2:1
- C. 1:4
- D. 1:1

Ans. D

Solution:

Power of equiconvex lens = P

i.e $P = \frac{1}{f}$, where f is focal length of equiconvex lens.

When an equiconvex lens is cut into two symmetrical halves by a plane containing the principal axis, then its focal length remains same.

Hence, power of lens (each halves)

$$\begin{aligned}P' &= \frac{1}{f} \Rightarrow P' = P \\ \Rightarrow \frac{P'}{P} &= 1 \\ \Rightarrow P : P &= 1 : 1\end{aligned}$$

69. The magnifying power of a telescope is 9. When it is adjusted for parallel rays, the distance between the objective and eyepiece is 20 cm. The ratio of focal length of objective lens to focal length of eyepiece is found to be m , then the value of m is

A. 8

B. 7

C. 9

D. 12

Ans. C

Solution:

Magnifying power of telescope, $m = 9$

$$\begin{aligned}\Rightarrow \frac{f_0}{f_e} &= 9 \\ \Rightarrow f_0 &= 9f_e \dots (i)\end{aligned}$$

Distance between objective and eyepiece is given as

$$\begin{aligned}f_0 + f_e &= 20 \dots (ii) \\ \Rightarrow 9f_e + f_e &= 20 \\ \text{[from Eq. (i)]} \\ \Rightarrow 10f_e &= 20 \\ \Rightarrow f_e &= 2 \text{ cm}\end{aligned}$$

\therefore From Eq. (i), $f_0 = 9 \times 2 = 18 \text{ cm}$

$$\therefore \frac{f_0}{f_e} = \frac{18}{2} = 9$$

70. In normal adjustment, for a refracting telescope, the distance between objective and eye piece is 30 cm. The focal length of the objective, when the angular magnification of the telescope is 2, will be:

- A. 20 cm
- B. 30 cm
- C. 10 cm
- D. 15 cm

Ans. A

Solution:

$$\therefore f_o + f_e = 30$$

$$\text{And magnification, } m = \frac{f_o}{f_e}$$

$$2 = \frac{f_o}{f_e} \Rightarrow f_o = 2f_e \Rightarrow f_o + \frac{f_o}{2} = 30 \therefore f_o = 20\text{cm}$$

71. If the distance between object and its two times magnified virtual image produced by a curved mirror is 15 cm, the focal length of the mirror must be:

- A. 10/3 cm
- B. -12 cm
- C. -10 cm
- D. 15 cm

Ans. C

Solution:

Since, image is magnified. So, it is a concave mirror.

$$\therefore m = 2 = \frac{-v}{u}$$

$$2 = \frac{-(15-u)}{-u}$$

$$2u = 15 - u$$

$$3u = 15 \Rightarrow u = 5 \text{ cm}$$

$$v = 15 - u = 15 - 5 = 10 \text{ cm}$$

By mirror formula,

$$\frac{1}{f} = \frac{1}{v} + \frac{1}{u}$$

$$= \frac{1}{10} + \frac{1}{(-5)} = \frac{1-2}{10} = \frac{-1}{10}$$

$$f = -10 \text{ cm}$$

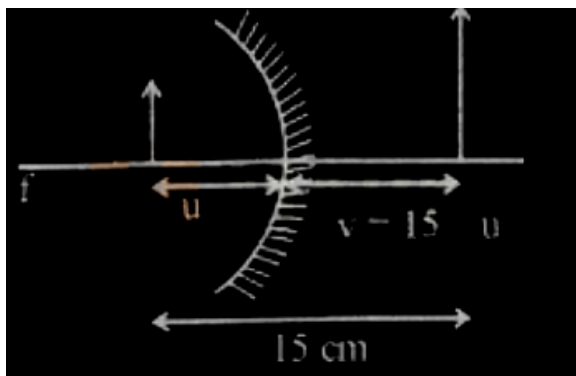

72. Young's double slit experiment is performed in a medium of refractive index of 1.33 . The maximum intensity is I_0 . The intensity at a point on the screen, where path difference between the light coming out from slits is $\lambda/4$, is

A. 0

B. $I_0/2$

C. $3I_0/8$

D. $2I_0/3$

Ans.

Solution:

Given, path difference, $\Delta x = \frac{\lambda}{4}$

Phase difference, $\phi = \left(\frac{2\pi}{\lambda}\right) \times (\text{Path difference})$

$$= \frac{2\pi}{\lambda} \times \frac{\lambda}{4} = \frac{\pi}{2} \dots (i)$$

It is given that, maximum intensity is I_0 . So, intensity at a point on the screen, where phase difference ϕ is given by

$$\begin{aligned} I &= I_0 \cos^2\left(\frac{\phi}{2}\right) \\ &= I_0 \times \cos^2\left(\frac{\pi/2}{2}\right) \quad [\because \text{using Eq.(i)}] \\ &= I_0 \times \left(\frac{1}{\sqrt{2}}\right)^2 \\ &= \frac{I_0}{2} \end{aligned}$$

73. In YDSE, monochromatic light falls on a screen 1.80 m from two slits separated by 2.08 mm . The first and second order bright fringes are separated by 0.553 mm . The wavelength of light used is

- A. 520 nm
- B. 639 nm
- C. 715 nm
- D. None of these

Ans. B

Solution:

Position of first bright fringe,

$$y_1 = \frac{\lambda D}{d}$$

Position of second bright fringe,

$$y_2 = \frac{2\lambda D}{d}$$
$$y_2 - y_1 = \frac{2\lambda D}{d} - \frac{\lambda D}{d}$$
$$y_2 - y_1 = \frac{\lambda D}{d}$$
$$\text{or } \lambda = \frac{(y_2 - y_1) d}{D}$$

Substituting given values, we have

$$\lambda = \frac{0.553 \times 10^{-3} \times 2.08 \times 10^{-3}}{1.8}$$
$$= 639 \times 10^{-9} \text{ m}$$
$$\text{or } \lambda = 639 \text{ nm}$$

74. A microwave of wavelength 2.0 cm falls normally on a slit of width 4.0 cm . The angular spread of the central maxima of the diffraction pattern obtained on a screen 1.5 m away from the slit, will be:

- A. 60°
- B. 45°
- C. 15°
- D. 30°

Ans. A

Solution:

Condition for minima is $d \sin \theta = n\lambda$

For 1st minima $d \sin \theta = \lambda$

$$\sin \theta = \frac{\lambda}{d} = \frac{2}{4} = \frac{1}{2} \quad \therefore \theta = 30^\circ$$

Angular spread = $2\theta = 60^\circ$

75. The property of light which cannot be explained by Huygen's construction of wavefront is

- A. Refraction
- B. Reflection

C. Diffraction

D. Origin of spectra

Ans. D

Solution:

The property of light which cannot be explained by Huygen's construction of wave front is origin of spectra.

76. When a light ray incidents on the surface of a medium, the reflected ray is completely polarized. Then the angle between reflected and refracted rays is

A. 45°

B. 90°

C. 120°

D. 180°

Ans. B

Solution:

According to Brewster's law if the reflected ray is completely polarized, then the reflected and refracted ray is perpendicular to each other.

Thus, $\theta = 90^\circ$

77. Which figure shows the correct variation of applied potential difference (V) with photoelectric current (I) at two different intensities of light ($I_1 < I_2$) of same wavelengths:

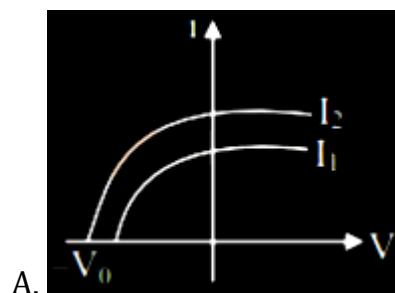

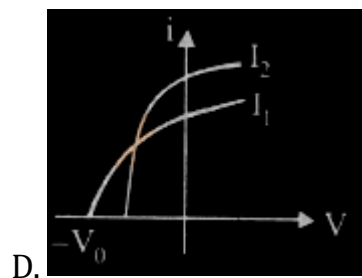
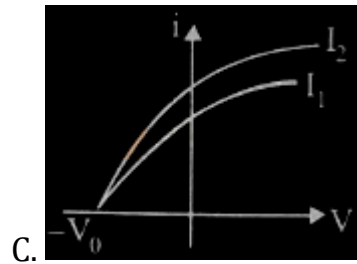
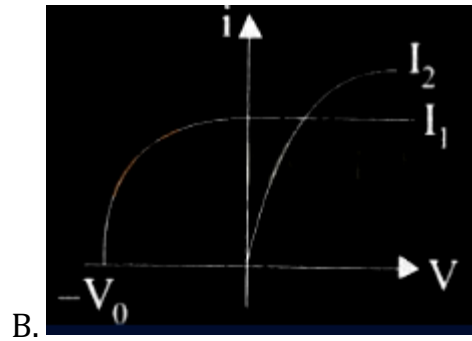

Ans. C

Solution:

Given lights are of same wavelength and stopping potential is independent on intensity. Hence stopping potential will remain same. Intensity $I_2 > I_1$, hence saturation current corresponding to I_2 will be greater than that corresponding to I_1 .

78. The acceptor level of a p-type semiconductor is 6 eV. The maximum wavelength of light which can create a hole would be : Given $hc = 1242 \text{ eV nm}$.

A. 407 nm

B. 414 nm

C. 207 nm

D. 103.5 nm

Ans. C

Solution:

Energy is, $E = \frac{hc}{\lambda}$

$$E = \frac{1242 \text{ nm-eV}}{\lambda} \Rightarrow \lambda = \frac{1242}{6} = 207 \text{ nm}$$

79. When light is incident on a metal surface the maximum kinetic energy of emitted electrons

- A. vary with intensity of light
- B. vary with frequency of light
- C. vary with speed of light
- D. vary irregularly

Ans. B

Solution:

Max. K.E. = $h\nu - W_0$; so Max. K.E. $\propto \nu$

80. If the kinetic energy of a free electron doubles, its de-Broglie wavelength changes by the factor

- A. 2
- B. 1/2
- C. $\sqrt{2}$
- D. $1/\sqrt{2}$

Ans. D

Solution:

de-Broglie wavelength,

$$\lambda = \frac{h}{p} = \frac{h}{\sqrt{2m \cdot (K \cdot E)}} \quad \therefore \lambda \propto \frac{1}{\sqrt{K \cdot E}}$$

If K.E is doubled, λ becomes $\frac{\lambda}{\sqrt{2}}$

81. Which of the following transitions of He^+ ion will give rise to spectral line which has same wavelength as the spectral line in hydrogen atom?

- A. $n = 4$ to $n = 2$

$$B. \quad n = 6 \rightarrow n = 5$$

$$C. \quad n = 6 \rightarrow n = 3$$

D. None of these

Ans. A

Solution:

Let the transition of electron in hydrogen atom ($Z = 1$) gives wavelength λ_1 for transition from n_2 to n_1 , then

$$\frac{1}{\lambda} = RZ^2 \left(\frac{1}{m^2} - \frac{1}{n^2} \right)$$

Here, $\lambda = \lambda_1, Z = 1, m = n_1, n = n_2$

$$\frac{1}{\lambda_1} = R(1)^2 \left(\frac{1}{n_1^2} - \frac{1}{n_2^2} \right) = R \left(\frac{1}{n_1^2} - \frac{1}{n_2^2} \right)$$

Now, if electron makes transition in He^+ ion from n_4 to n_3 and gives wavelength λ_2 , then

$$\begin{aligned} \frac{1}{\lambda_2} &= R(2)^2 \left(\frac{1}{n_3^2} - \frac{1}{n_4^2} \right) \\ &= R \left[\frac{1}{\left(\frac{n_3}{2}\right)^2} - \frac{1}{\left(\frac{n_4}{2}\right)^2} \right] \end{aligned}$$

Given that, $\lambda_1 = \lambda_2$

$$\Rightarrow R \left(\frac{1}{n_1^2} - \frac{1}{n_2^2} \right) = R \left[\frac{1}{\left(\frac{n_3}{2}\right)^2} - \frac{1}{\left(\frac{n_4}{2}\right)^2} \right]$$

On comparing both sides, we get

$$n_1 = \frac{n_3}{2} \text{ and } n_2 = \frac{n_4}{2}$$

The value of n_1, n_2, n_3 and n_4 must be an integer, as they denote principal quantum number.

If $n_3 = 2$ and $n_4 = 4$, then the given condition is satisfied.

82. The ratio of the shortest wavelength of Balmer series to the shortest wavelength of Lyman series for hydrogen atom is:

A. 4:1

B. 1:2

C. 1:4

D. 2:1

Ans. A

Solution:

Wavelength of H -atom is

$$\frac{1}{\lambda} = RZ^2 \left(\frac{1}{n_1^2} - \frac{1}{n_2^2} \right)$$

Shortest wavelength for Balmer series:

$$\frac{1}{\lambda_B} = RZ^2 \left(\frac{1}{2^2} - \frac{1}{\infty} \right)$$

Shortest wavelength for Lyman series:

$$\frac{1}{\lambda_L} = RZ^2 \left(\frac{1}{1^2} - \frac{1}{\infty} \right) \dots \text{(ii)}$$

Dividing eq. (i) and (ii),

$$\lambda_A : \lambda_1 = 4 : 1$$

83. The minimum excitation energy of an electron revolving in the first orbit of hydrogen is

- A. 3.4 eV
- B. 8.5 eV
- C. 10.2 eV
- D. 13.6 eV

Ans. C

Solution:

Energy of electron in nth n^{th} orbit

$$E_n = \frac{-13.6\text{eV}}{n^2}$$

Excitation energy of electron from $n = 1$ to $n = 2$

$$E = -13.6 \left[\frac{1}{2^2} - \frac{1}{1} \right] = -13.6 \left[\frac{1}{4} - \frac{1}{1} \right] = 10.2\text{eV}$$

84. The atomic mass of ${}_6\text{C}^{12}$ is 12.000000 u and that of ${}_6\text{C}^{13}$ is 13.003354 u. The required energy to remove a neutron from ${}_6\text{C}^{13}$, if mass of neutron is 1.008665 u, will be:

- A. 62.5 MeV
- B. 6.25 MeV
- C. 4.95 MeV
- D. 49.5 MeV

Ans. C

Solution:

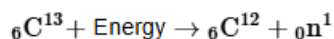

$$\text{Mass defect, } \Delta m = (12.000000 + 1.008665) - 13.003354$$

$$= -0.00531\text{u}$$

$$\therefore \text{Energy required} = \Delta m \times 931.5 = 0.00531 \times 931.5$$

$$\text{MeV} = 4.95\text{MeV}$$

85. The nucleus having highest binding energy per nucleon is

- A. ${}^8_{16}\text{O}$
- B. ${}^{26}_{56}\text{Fe}$
- C. ${}^{84}_{208}\text{Pb}$
- D. ${}^2_4\text{He}$

Ans. B

Solution:

The binding energy per nucleon is practically independent of the atomic number for nuclei of mass number in range $30 < A < 170$.

So, ${}^{56}_{26}\text{Fe}$ has maximum binding energy per nucleon.

86. Identify the correct output signal Y in the given combination of gates for the given inputs A and B shown in the figure.

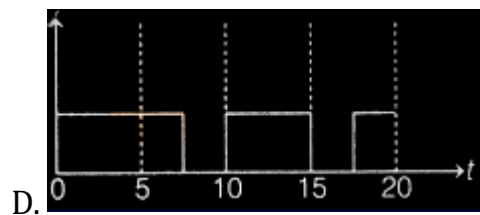
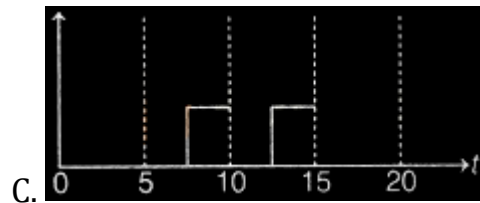
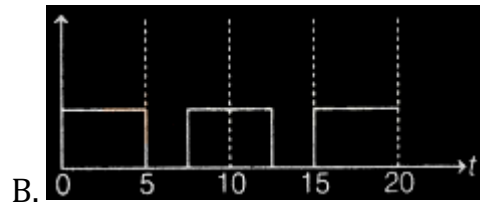
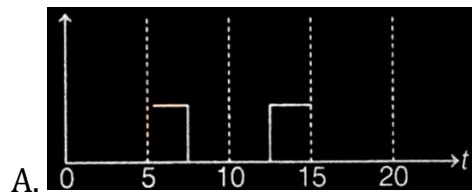
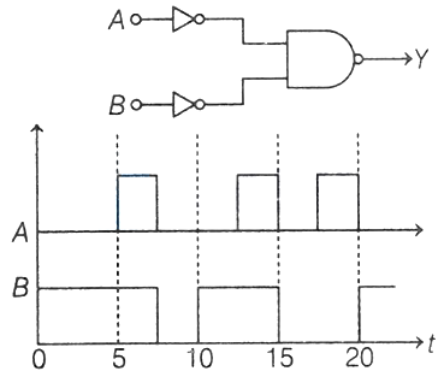

Ans. D

Solution:

Given circuit can be shown as below

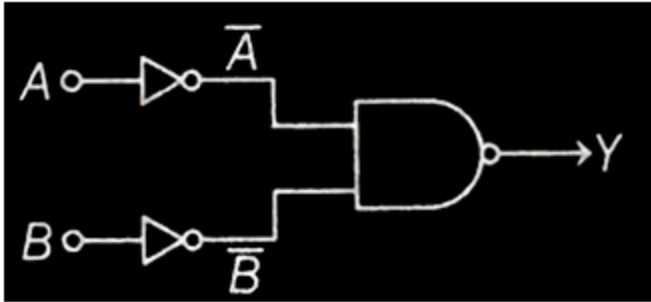

Output, $Y = \overline{(\bar{A})(\bar{B})} = \bar{A} + \bar{B} = A + B$

The truth table will be

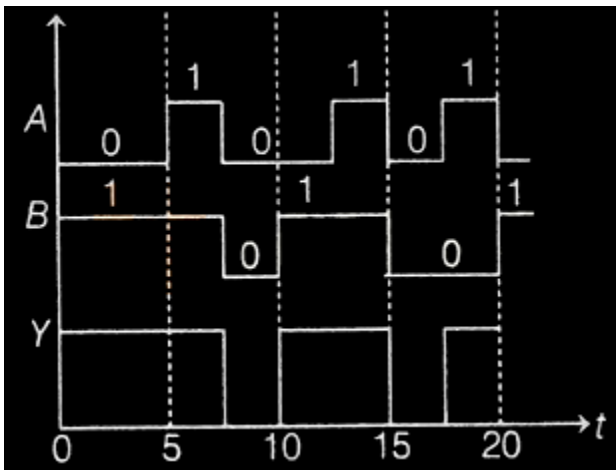

The corresponding input and output waveforms are shown below.

A	B	$Y=A+B$
0	0	0
0	1	1
1	0	1
1	1	1

87. Identify the logic gate given in the circuit:

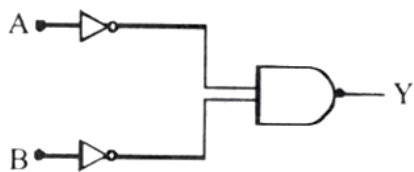

- A. NAND - gate
- B. OR - gate
- C. AND gate
- D. NOR gate

Ans. B

Solution:

$$\text{Output } Y = \overline{\overline{A} \cdot \overline{B}} = \overline{\overline{A + B}} \text{ (By De-Morgan Law)}$$

$$\therefore Y = A + B$$

This Boolean expression represents OR gate.

88. A reverse biased zener diode when operated in the breakdown region works as

- A. an amplifier
- B. an oscillator
- C. a voltage regulator
- D. a rectifier

Ans. C

Solution:

In the breakdown region, a reverse biased zener diode works as a voltage regulator.

89. Identify the logic operation performed by the following circuit.

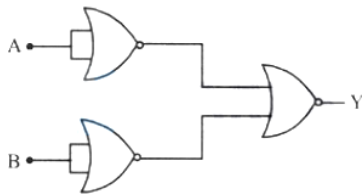

- A. OR
- B. AND
- C. NOT
- D. NAND

Ans. B

Solution:

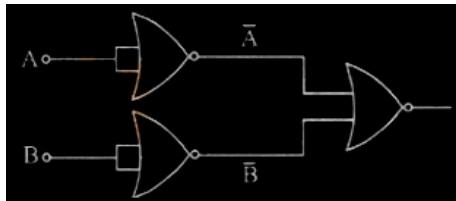

$$Y = \overline{\overline{A} + \overline{B}}$$

$$= \overline{\overline{A} \cdot \overline{B}}$$

$$= A \cdot B$$

So, $Y = A \cdot B$

Therefore gate is AND gate.

90. One main scale division of a vernier caliper is equal to m units. If m^{th} division of main scale coincides with $(n + 1)^{\text{th}}$ division of vernier scale, the least count of the vernier caliper is:

A. $\frac{n}{(n+1)}$

B. $\frac{m}{(n+1)}$

C. $\frac{1}{(n+1)}$

D. $\frac{m}{n(n+1)}$

Ans. B

Solution:

Given 1 Main scale division = m

$$nMSD = (n + 1)VSD$$

$$\Rightarrow 1VSD = \frac{n}{n+1}MSD$$

$$\text{Least count of vernier caliper} = 1MSD - 1VSD$$

$$\Rightarrow L.C = m - m\left(\frac{n}{n+1}\right) = \left(1 - \frac{n}{n+1}\right)m$$

$$= m\left(\frac{n+1-n}{n+1}\right) = \left(\frac{1}{n+1}\right)m \Rightarrow L.C = \left(\frac{m}{n+1}\right)$$

Chemistry

1. 1 L closed flask contains a mixture of 4 g of methane and 4.4 g of carbon dioxide. The pressure inside the flask at 27°C is [Assume ideal behaviour of gases]

A. 8.6 atm

B. 2.2 atm

C. 4.2 atm

D. 6.1 atm

Ans. A

Solution:

$$\text{no. of moles of } CH_4 (n_1) = \frac{4}{16} = 0.25 \text{ mol}$$

$$\text{no. of moles of } CO_2 (n_2) = \frac{4.4}{44} = 0.1 \text{ mol}$$

$$\text{Total no. of moles } (n_T) = n_1 + n_2 = 0.35 \text{ mol}$$

$$\therefore P = \frac{0.35 \times 0.082 \times 300}{1} = 8.6 \text{ atm}$$

2. In which mode of expression, the concentration of a solution remains independent of temperature?

A. Molarity

B. Normality

C. Fermality

D. Molality

Ans. D

Solution:

Molality-Moles of solute/mass of solvent in kg

∴ Molality does not involve volume term.

∴ It is independent of temperature.

3. The degeneracy of hydrogen atom that has energy equal to $\frac{-R_H}{9}$ is (where, R_H = Rydberg constant)

A. 6

B. 8

C. 5

D. 9

Ans. D

Solution:

The energy is given as, $E = -\frac{R_H}{n^2} \dots (i)$

We know that,

$$E_n = -\frac{R_H}{n^2} \dots (ii)$$
$$n^2 = 9$$
$$n = 3$$

When $n = 3, l = 0, 1, 2$

(3s, 3p, 3d sub-shells)

Orbitals present (i.e., degeneracy),

$$3s = 1, 3p = 3, 3d = 5$$

$$\text{Total number of orbital present} = 3 + 1 + 5 = 9$$

4. If the de-broglie wavelength of a particle of mass (m) is 100 times its velocity. Then, its value in terms of its mass (m) and plank constant (h) is

A. $\frac{1}{10} \sqrt{\frac{m}{h}}$

B. $10\sqrt{\frac{h}{m}}$

C. $\frac{1}{10}\sqrt{\frac{h}{m}}$

D. $10\sqrt{\frac{m}{h}}$

Ans. B

Solution:

Let the wavelength of given particle = x

$$\text{Velocity } (v) = \frac{x}{100}$$

Using wavelength formula:

$$\lambda = \frac{h}{mv}$$

$$\therefore x = \frac{h}{m\left(\frac{x}{100}\right)}$$

$$x = \frac{100h}{mx}$$

$$x^2 = 100\frac{h}{m}$$

$$\Rightarrow x = 10\sqrt{\frac{h}{m}}$$

5. The energy of second orbit of hydrogen atom is -5.45×10^{-19} J. What is the energy of first orbit of Li^{2+} ion (in J) ?

A. -1.962×10^{-18}

B. -1.962×10^{-17}

C. -3.924×10^{-17}

D. -3.924×10^{-18}

Ans. B

Solution:

$$E_n = -13.6 \left[\frac{z^2}{n^2} \right] \text{ eV}$$

$$\Rightarrow E_1 = -13.6 \left[\frac{3^2}{1^2} \right] \text{ eV} = -122.4 \text{ eV}$$

$$= -122.4 \times 1.602 \times 10^{-19} \text{ J} = -1.962 \times 10^{-17} \text{ J}$$

6. A photon of wavelength 3000\AA ... strikes a metal surface. The work function of the metal is 2.13 eV. What is the kinetic energy of the emitted photoelectron?

$$(h = 6.626 \times 10^{-34} \text{ Js})$$

A. 4.0 eV

B. 3.0 eV

C. 2.0 eV

D. 1.0 eV

Ans. C

Solution:

$$\lambda = 3000\text{\AA} \dots = 3 \times 10^{-7} \text{ m}, \phi = 2.13 \text{ eV}$$

$$\text{K.E.} = hv - hv_0 = hv - \phi = \frac{hc}{\lambda} - \phi$$

$$= \frac{(6.626 \times 10^{-34} \times 3 \times 10^8)}{3 \times 10^{-7}} - (2.13 \times 1.6 \times 10^{-19})$$

$$= \frac{1.98 \times 10^{-25}}{3 \times 10^{-7}} - (3.408 \times 10^{-19})$$

$$= (6.60 \times 10^{-19}) - (3.408 \times 10^{-19})$$

$$= 3.192 \times 10^{-19} \text{ J} = 2.0 \text{ eV}$$

7. A stream of electrons from a heated filament was passed between two charged plates kept at a potential difference V volt. If 'e' and m are charge and mass of an electron, respectively, then the value of h/λ (where λ is wavelength associated with electron wave) is given by:

A. \sqrt{meV}

B. $\sqrt{2meV}$

C. meV

D. 2meV

Ans. B

Solution:

As electron of charge ' e ' is passed through ' V ' volt, kinetic energy of electron will be eV .

$$\text{Wavelength of electron wave } (\lambda) = \frac{h}{\sqrt{2m \cdot \text{KE}}}$$

$$\lambda = \frac{h}{\sqrt{2meV}} \quad \therefore \frac{h}{\lambda} = \sqrt{2meV}$$

8. Electron affinity is positive, when

A. O changes into O⁻

B. O⁻ changes to O²⁻

C. O changes into O⁺

D. O changes to O²⁺

Ans. B

Solution:

When O⁻ changes into O²⁻, energy is absorbed i.e the change is endothermic because O⁻ repels the incoming electron due to similar charge.

Hence, it needs energy to add (accept) the electron. So, electron affinity (EA₂) is positive.

9. The ionic radii in (Å...) of N³⁻, O²⁻ and F⁻ are respectively.

A. 1.71, 1.40 and 1.36

B. 1.71, 1.36 and 1.40

C. 1.36, 1.40 and 1.71

D. 1.36, 1.71 and 1.40

Ans. A

Solution:

N^{3-} , O^{2-} and F^- are isoelectronic (10 electrons) species. Their ionic radii will decrease with increase in magnitude of the nuclear charge from N ($Z = 7$) to O ($Z = 8$) and F ($Z = 9$).

i.e.

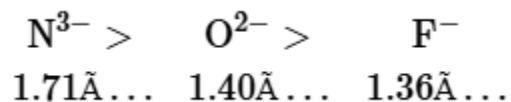

Hence, option (1) is correct.

10. Intramolecular hydrogen bonding is found in

- A. o-nitrophenol
- B. m-nitrophenol
- C. p-nitrophenol
- D. phenol

Ans. A

Solution:

In o-nitrophenol, hydrogen of O – H group and oxygen of nitro group form intramolecular hydrogen bonding producing a six membered ring structure while in m-nitrophenol, p-nitrophenol and phenol, intermolecular hydrogen bonding are present.

The structure is,

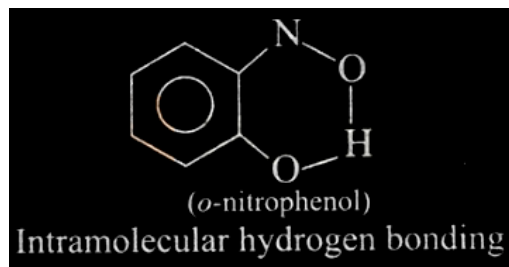

11. The hybridisation scheme for the central atom includes a d-orbital contribution in

- A. I_3^-
- B. PCl_3

C. NO_3^-

D. H_2Se

Ans. A

Solution:

I_3^- is linear with central iodine atom undergoing sp^3d -hybridisation and three lone pairs occupying equatorial position.

Thus, this structure include d-orbital contribution to the hybridisation scheme.

The structure is,

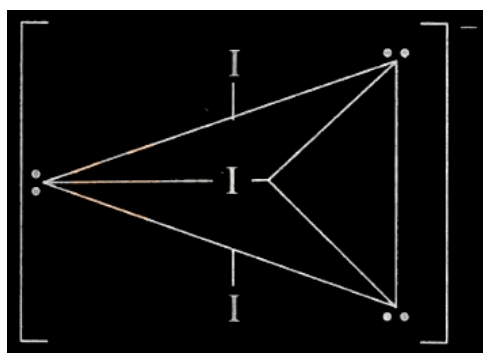

PCl_3 structure is sp^3 -hybridised with one lone pair.

NO_3^- is sp^2 -hybridised and H_2Se is sp^3 - hybridised with two lone pairs of Se atom.

12. In the following species, how many species have same magnetic moment?

(i) Cr^{2+}

(ii) Mn^{3+}

(iii) Ni^{3+}

(iv) Sc^{2+}

(v) Zn^{2+}

(vi) V^{3+}

(vii) Ti^+

A. 1

B. 3

C. 2

D. 4

Ans. C

Solution:

Among the given species, Cr^{2+} and Mn^{3+} have same number of unpaired electrons.

Unpaired electrons, $n = 4$

$$\begin{aligned}\text{Magnetic moment, } \mu &= \sqrt{n(n+2)} = \sqrt{4(4+2)} \\ &= \sqrt{24}\text{BM}\end{aligned}$$

13. The spin only magnetic moment of Fe^{3+} ion (in BM) is approximately.

A. 4

B. 5

C. 6

D. 7

Ans. C

Solution:

Electronic configuration of Fe.

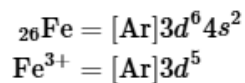

Number of unpaired electrons, $n = 5$

Spin only magnetic moment, $\mu_s = \sqrt{n(n+2)}\text{BM}$

$$\begin{aligned}\mu_s &= \sqrt{5(5+2)} \\ &= \sqrt{35} \\ \mu_s &= 5.85\text{BM or } \mu_s \simeq 6\text{BM}\end{aligned}$$

14. Which one of the following compounds is having maximum 'lone pair-lone pair' electron repulsions?

A. ClF_3

B. IF_5

C. SF_4

D. XeF₂

Ans. D

Solution:

XeF₂ has three lone pairs and two bond pairs. The three lone pairs are arranged in the equatorial positions because of which they face maximum repulsion from each other.

15. Identify the species having one π -bond and maximum number of canonical forms from the following:

A. SO₃

B. O₂

C. SO₂

D. CO₃²⁻

Ans. D

Solution:

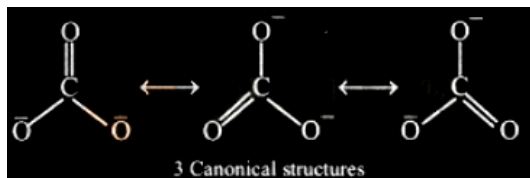

16. sp³ d² hybridisation is not displayed by :

A. BrF₅

B. SF₆

C. [CrF₆]³⁻

D. PF₅

Ans. D

Solution:

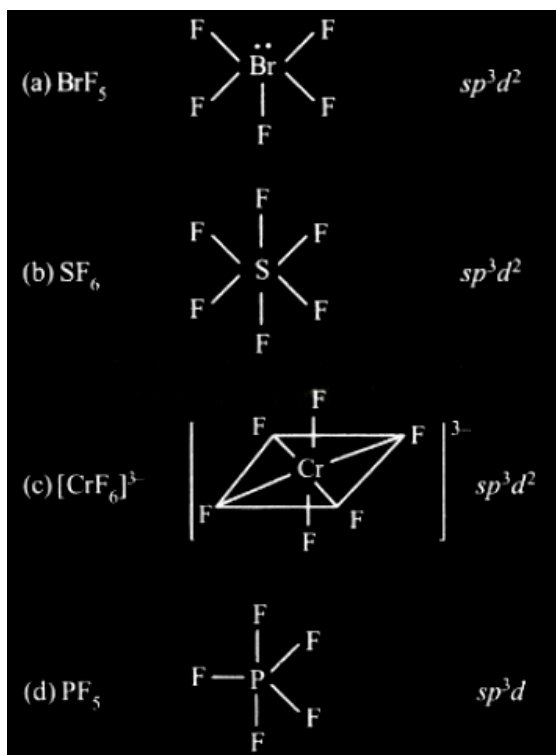

17. What would be the amount of heat absorbed in the cyclic process shown below?

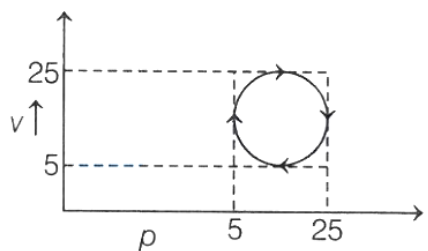

- A. 5π J
- B. 15π J
- C. 25π J
- D. 100π J

Ans. D

Solution:

In a cyclic process, internal energy change = 0

According to 1st law of thermodynamics

$$\Delta U = \Delta q + \Delta W$$

$$\text{As, } \Delta U = 0, \quad \Delta q = -\Delta W$$

From the graph, work done = ΔW = Area under curve Here, area of circle = πr^2

$$= \pi \left(\frac{25 - 5}{2} \right)^2 = \pi \times 10^2$$

$$\therefore \Delta q = 100\pi \text{ J}$$

18. The bond dissociation energy of X_2 , Y_2 and XY are in the ratio of 1 : 0.5 : 1. ΔH for the formation of XY is -200 kJ/mol. The bond dissociation energy of X_2 will be

- A. 200 kJ/mol
- B. 100 kJ/mol
- C. 400 kJ/mol
- D. 800 kJ/mol

Ans. D

Solution:

Let the bond dissociation energy of $X_2 = a$ kJ/mol

i.e. $BE(X_2) = a$ kJ/mol

Then, $BE(Y_2) = 0.5a$

and $BE(XY) = a$ kJ/mol

Given, $\frac{1}{2}X_2 + \frac{1}{2}Y_2 \rightarrow XY, \Delta H = -200$ kJ/mol

$$\Delta_r H = BE(\text{Reactants}) - BE(\text{Product})$$

$$\Delta_r H = \left[\frac{1}{2}BE(X_2) + \frac{1}{2}BE(Y_2) \right] - BE(XY)$$

$$\therefore -200 = \frac{a}{2} + \frac{0.5a}{2} - a$$

$$a = \frac{200}{0.25} = 800 \text{ kJ/mol}$$

19. Which of the following relation is not correct?

- A. $\Delta H = \Delta U - P\Delta V$
- B. $\Delta U = q + W$
- C. $\Delta S_{\text{sys}} + \Delta S_{\text{surr}} \geq 0$

$$D. \Delta G = \Delta H - T\Delta S$$

Ans. A

Solution:

$$H = U + PV \text{ (By definition)}$$

$$\Delta H = \Delta U + \Delta(PV) \text{ at constant pressure}$$

$$\Delta H = \Delta U + P\Delta V$$

20. The standard Gibbs energy (ΔG^0) for the following reaction is

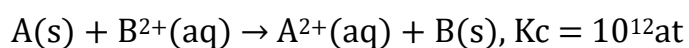

(K_c = equilibrium constant)

A. -150 kJ

B. -96.80 kJ

C. -68.47 kJ

D. -100 kJ

Ans. C

Solution:

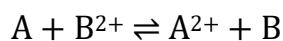

$$G^\circ = -RT \ln K_c$$

$$= -8.314 \times 298 \times 2.303 \times \log 10^{12} = 68.47 \text{ kJ/mol}$$

21. The combustion of benzene (L) gives $\text{CO}_2(\text{g})$ and $\text{H}_2\text{O}(\text{L})$. Given that heat of combustion of benzene at constant volume is $-3263.9 \text{ kJ mol}^{-1}$ at 25°C ; heat of combustion (in kJ mol^{-1}) of benzene at constant pressure will be:

$$(R = 8.314 \text{ J K}^{-1} \text{ mol}^{-1})$$

A. 4152.6

B. 452.46

C. 3260

D. -3267.6

Ans. D

Solution:

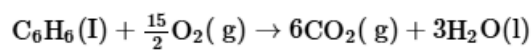

$$\Delta n_g = 6 - \frac{15}{2} = -\frac{3}{2}$$

$$\Delta H = \Delta U + \Delta n_g RT$$

$$= -3263.9 + \left(-\frac{3}{2}\right) \times 8.314 \times 10^{-3} \times 298$$

$$= -3263.9 + (-3.71) = -3267.6 \text{ kJ mol}^{-1}$$

22. Choose the correct option for free expansion of an ideal gas under adiabatic condition from the following:

A. $q = 0, \Delta T \neq 0, w = 0$

B. $q = 0, \Delta T < 0, w \neq 0$

C. $q \neq 0, \Delta T = 0, w = 0$

D. $q = 0, \Delta T = 0, w = 0$

Ans. D

Solution:

$$\Delta U = q + w$$

For a adiabatic process,

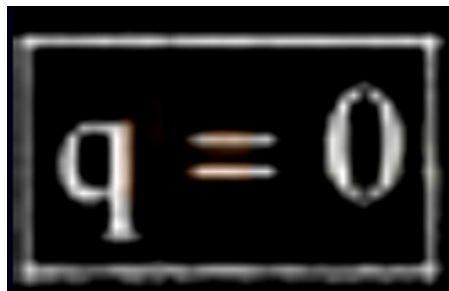
$$q = 0$$

$$\Delta U = w = -p_{\text{ex}}\Delta v$$

For free expansion of ideal gas $p_0 = 0$

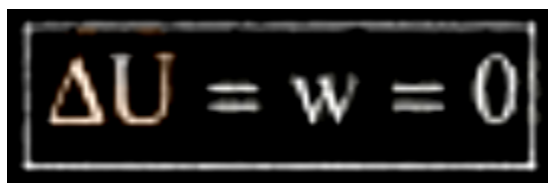
$$\Delta U = w = 0$$

As $\Delta U = C\Delta T = 0$

$$\Delta T = 0$$

23. Le-Chateliers' principle is not applicable to

- A. $\text{H}_2(\text{g}) + \text{I}_2(\text{g}) \rightleftharpoons 2\text{HI}(\text{g})$
- B. $\text{Fe}(\text{s}) + \text{S}(\text{s}) \rightleftharpoons \text{FeS}(\text{s})$
- C. $\text{N}_2(\text{g}) + 3\text{H}_2(\text{g}) \rightleftharpoons 2\text{NH}_3(\text{g})$
- D. $\text{N}_2(\text{g}) + \text{O}_2(\text{g}) \rightleftharpoons 2\text{NO}(\text{g})$

Ans. B

Solution:

Le-Chatelier principle is not applicable to pure solids and liquids because they experience negligible change in concentration during chemical equilibrium.

24.

The ratio $\frac{K_P}{K_C}$ for the reaction

$\text{CO}(\text{g}) + \frac{1}{2}\text{O}_2(\text{g}) \rightleftharpoons \text{CO}_2(\text{g})$ is:

- A. $(RT)^{1/2}$
- B. RT
- C. 1
- D. $1/\sqrt{RT}$

Ans. D

Solution:

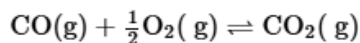

K_P and K_C are related as

$$K_P = K_C(RT)^{\Delta n_g}$$

$$\Rightarrow \Delta n_g = n_P - n_R = 1 - 1\frac{1}{2} = -\frac{1}{2}$$

$$\Delta n_g \text{ for the given reaction} = -\frac{1}{2}$$

$$\therefore \frac{K_P}{K_C} = \frac{1}{\sqrt{RT}}$$

25. The pH of 1 N aqueous solutions of HCl, CH₃COOH and HCOOH follows the order:

- A. HCl > HCOOH > CH₃COOH
- B. HCl = HCOOH > CH₃COOH
- C. CH₃COOH > HCOOH > HCl
- D. CH₃COOH = HCOOH > HCl

Ans. C

Solution:

Stronger the acid, lower is the pH or weaker the acid, higher the pH .

The strength of the given acid is in the order



Hence, their pH is in the order

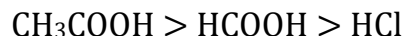

26. 20 mL of 0.1 M acetic acid is mixed with 50 mL of potassium acetate. K_a of acetic acid = 1.8×10^{-5} at 27°C. Calculate the concentration of potassium acetate if pH of mixture is 4.8 .

- A. 0.1 M
- B. 0.04 M
- C. 0.03 M
- D. 0.02 M

Ans. B

Solution:

For an acidic buffer,

$$\text{pH} = \text{p}K_a + \log \frac{[\text{Salt}]}{[\text{Acid}]} \dots (i)$$

Let the concentration of potassium acetate solution = $x\text{M}$ 20 mL of 0.1 M acetic acid = 20×0.1 millimol = 2 millimol

50 mL of $x\text{M}$ potassium acetate = $x \times 50$ millimol

$$= 50x \text{ millimol}$$

$$\text{pH} = 4.8 (\text{Given})$$

Substitute all value in eq. (i),

$$4.8 = -(\log 1.8 + 10^{-5}) + \log \frac{50x}{2}$$

$$\log 25x = 0.06$$

$$x = 0.04\text{M}$$

27. What is the stoichiometric coefficient of SO_2 in the following balance reaction?

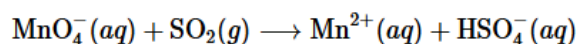

(in acidic solution)

A. 5

B. 4

C. 3

D. 2

Ans. A

Solution:

Oxidation half reaction:

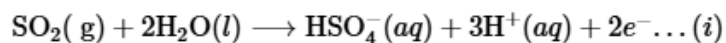

Reduction half reaction:

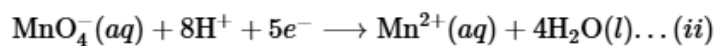

Multiply eq. (i) by 5 and (ii) by 2 and then add

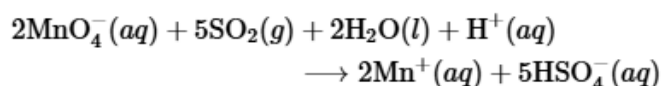

Thus, the stoichiometric coefficient of SO_2 in the above balance equation is 5 .

28. Volume of M/8 KMnO_4 solution required to react completely with 25.0 cm^3 of M/4 FeSO_4 in acidic medium is.

- A. 8.0 mL
- B. 5.0 mL
- C. 15.0 mL
- D. 10.0 mL

Ans. D

Solution:

The balance ionic equation for the reaction is

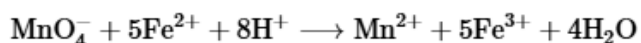

From the above equation it is clear that 1 mole of $\text{KMnO}_4 = 5$ moles of FeSO_4 .

Apply molarity equation to balance the redox reaction

$$\begin{aligned} \frac{M_1 V_1}{n_1} (\text{KMnO}_4) &= \frac{M_2 V_2}{n_2} (\text{FeSO}_4) \\ \frac{1 \times V_1}{8 \times 1} &= \frac{1}{4} \times \frac{25}{5} \\ V_1 &= \frac{1 \times 25 \times 8}{4 \times 5} \\ V_1 &= 10 \text{ cm}^3 \text{ or } V_1 = 10.0 \text{ mL} \end{aligned}$$

29. Which of the following is only a redox reaction but not a disproportionation reaction?

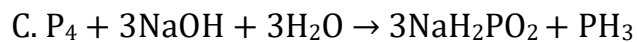
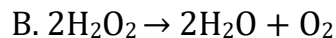
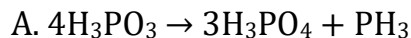

Ans. D

Solution:

The reaction $\text{P}_4 + 8\text{SOCl}_2 \rightarrow 4\text{PCl}_3 + 2\text{S}_2\text{Cl}_2 + 4\text{SO}_2$ involves change of oxidation state of P from 0 to +3 and that of S from +4 to +2 .

Thus, it is a redox reaction but not a disproportionation reaction.

30. Among the following the correct statements are

I. LiH, BeH₂ and MgH₂ are saline hydrides with significant covalent character

II. Saline hydrides are volatile

III. Electron - precise hydrides are Lewis bases

IV. The formula for chromium hydride is CrH

A. I, III only

B. II, IV only

C. I, IV only

D. III, IV only

Ans. C

Solution:

Saline hydrides are not volatile as the strong ionic bonds keep the constituent ions together.

Thus, statement II is incorrect.

Electron-precise hydrides like CH₄, SiH₄, act as pH - neutral species.

Thus, statement 3 is incorrect.

31. In which of the following reactions of H_2O_2 acts as an oxidising agent (either in acidic, alkaline or neutral medium)?

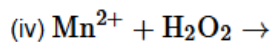
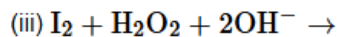
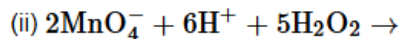
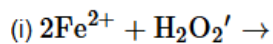

A. (ii),(iii)

B. (i), (iv)

C. (i), (iii)

D. (ii), (iv)

Ans. B

Solution:

Let us complete the reactions:

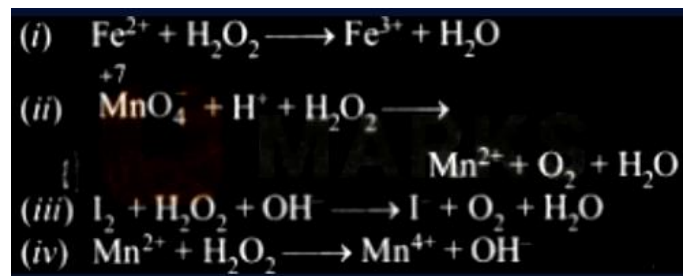

In reactions, (i) and (iv) H_2O_2 , acts as oxidising agent and itself gets reduced to H_2O ,

32. The strongest reducing agent among the following is:

A. SbH_3

B. NH_3

C. BiH_3

D. PH_3

Ans. C

Solution:

The stability of hydrides decreases from NH_3 to BiH_3 but their reducing character increases down the group.

33. The correct order of melting points of the following salts is



A. $\text{I} > \text{II} > \text{III}$

B. $\text{II} > \text{I} > \text{III}$

C. $\text{III} > \text{II} > \text{I}$

D. $\text{II} > \text{III} > \text{I}$

Ans. B

Solution:

Smaller the size of anion, smaller is the covalent character and higher will be its melting point. Hence, the order of melting point of lithium salts is $\text{LiF} > \text{LiCl} > \text{LiBr}$.

34. Which among the following is used in detergent

A. Sodium acetate

B. Sodium stearate

C. Calcium stearate

D. Sodium lauryl sulphate

Ans. D

Solution:

Sodium stearate is used in soap and sodium lauryl sulphate

$\text{CH}_3(\text{CH}_2)_{10}\text{CH}_2 - \text{OSO}_3^\ominus\text{Na}^\oplus$ is an anionic detergent

35. Thermal decomposition of lithium nitrate gives

A. LiO_2 , O_2 , NO_2

B. Li_2O , O_2 , N_2O

C. Li_2O , O_2 , N_2

D. Li_2O , O_2 , NO_2

Ans. D

Solution:

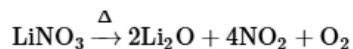

lithium nitrate

36. The number of geometrical isomers possible for the compound, $\text{CH}_3\text{CH}=\text{CH}-\text{CH}=\text{CH}_2$ is

A. 2

B. 3

C. 4

D. 6

Ans. A

Solution:

Although $\text{CH}_3\text{C}=\text{CH}-\text{CH}=\text{CH}_2$ has two double bond but one of them has two similar atoms (i.e. H-atom) therefore no geometrical isomerism is possible around the double bond. However each carbon atom of other double bond has two different atoms/groups and hence geometrical isomerism is possible around this double bond.

Hence, only two geometrical isomers are possible.

37. Correct order of stability of carbanion is

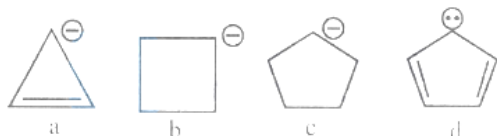

A. $\text{C} > \text{B} > \text{D} > \text{A}$

B. $\text{A} > \text{B} > \text{C} > \text{D}$

C. $\text{D} > \text{A} > \text{C} > \text{B}$

D. $D > C > B > A$

Ans. D

Solution:

As we know compound (4) is aromatic and the compound (1) is anti-aromatic. Hence compound (4) is most stable and compound (1) is least stable among these in compound (2) and (3) carbon atom having charge is sp^3 hybridised. On the basis of angle strain theory compound (3) is more stable than compound (2).



38. Which of the following is not correct about Grignard reagent?

- A. It is a nucleophile
- B. Forms new carbon-carbon bond
- C. Reacts with carbonyl compounds
- D. It is an organomanganese compound

Ans. D

Solution:

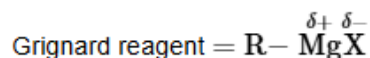

39. The IUPAC name of the following molecule is

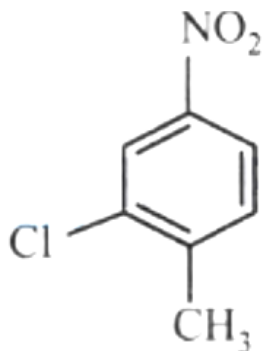

- A. 2-Methyl-5 nitro-1-chlorobenzene
- B. 3-Chloro-4 methyl-1-nitrobenzene
- C. 2-Chloro-1 methyl-4-nitorbenzene

D. 2-Chloro-4 nitro-1-methylbenzene

Ans. C

Solution:

–NO₂ and -Cl are written as prefixes with CH₃ being given the highest preference for numbering (C–1).

Thus, the name of the compound will be 2– chloro-1-methyl-4-nitrobenzene.

40. Choose the correct stability order of the given free radicals.

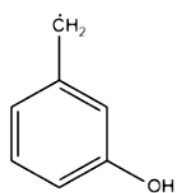

I

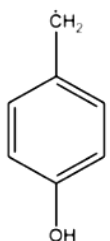

II

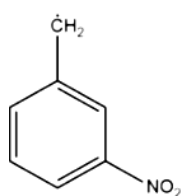

III

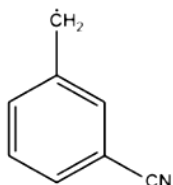

IV

A. I > II > III > IV

B. II > I > IV > III

C. II = I > IV > III

D. III > IV > II > I

Ans. B

Solution:

In compounds (I), (III) and (IV) the -M effect and hyperconjugation effect are inoperative at meta positions. So we should consider the inductive effect of the groups. -I effect will decrease the stability of the free radical by withdrawing the electrons toward it itself. The order of -I effect is NO₂ > CN > OH. Therefore (III) is most destabilised.

In compound (II) the OH act as electron donating group through +M effect which is operative at para position. This increase the electron density at para position and

stabilise the free radical. Hence compound (1) is most stabilised. The order of stability of free radical is

II > I > IV > III

41. Which of the following is strongest Bronsted base?

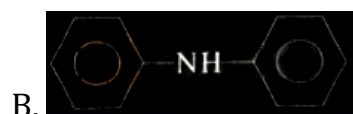
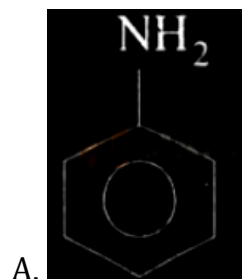

Ans. D

Solution:

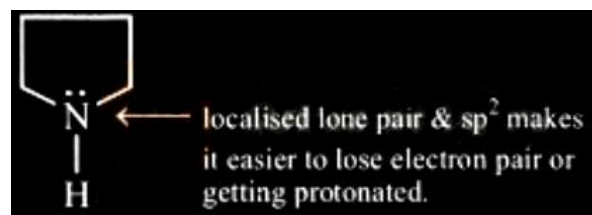

42. The major product X in the following given reaction is

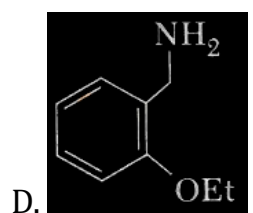
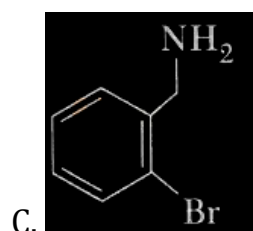
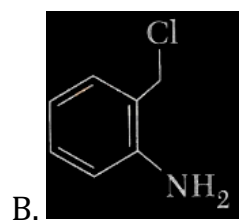
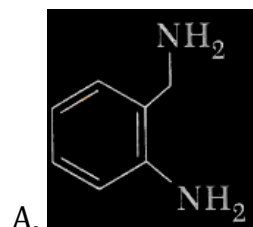
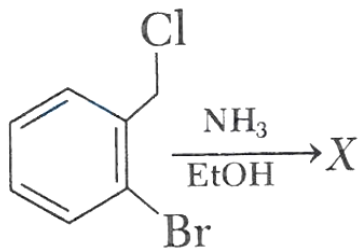

Ans. C

Solution:

Since, benzyl halides are more reactive than aryl halides, therefore reaction occur at the benzyl chloride part.

The reaction is as follow,

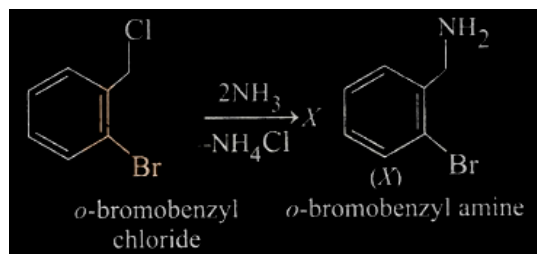

43. The major product of the reaction between $\text{CH}_3\text{CH}_2\text{ONa}$ and $(\text{CH}_3)_3\text{CCl}$ in ethanol is

- A. $\text{CH}_3\text{CH}_2\text{OC}(\text{CH}_3)_3$
- B. $\text{CH}_2 = \text{C}(\text{CH}_3)_2$
- C. $\text{CH}_3\text{CH}_2\text{C}(\text{CH}_3)_3$
- D. $\text{CH}_3\text{CH} = \text{CHCH}_3$

Ans. B

Solution:

Tertiary alkyl halides readily undergo dehydrohalogenation to form alkenes.

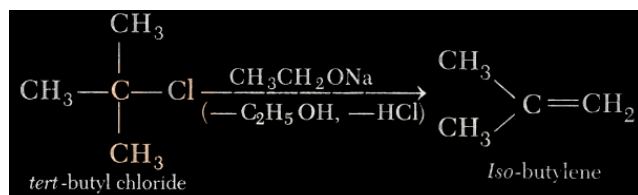

44. Dinitrogen is a robust compound, but reacts at high altitude to form oxides. The oxide of nitrogen that can damage plant leaves and retard photosynthesis is :

- A. NO
- B. NO_3^-
- C. NO_2
- D. NO_2^-

Ans. C

Solution:

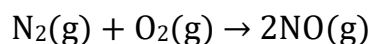

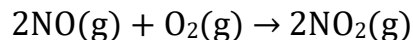

Higher concentration of NO_2 damage the leaves and retard the rate of photosynthesis.

45. A decimolar solution potassium ferrocyanide is 50% dissociated at 300 K. The osmotic pressure of solution is ($R = 8.314 \text{ JK}^{-1} \text{ mol}^{-1}$)

A. 7.48 atm

B. 4.99 atm

C. 3.74 atm

D. 6.23 atm

Ans. A

Solution:

$$\alpha = 0.5 \alpha \text{ (50\% dissociated)}$$

The reaction involves is

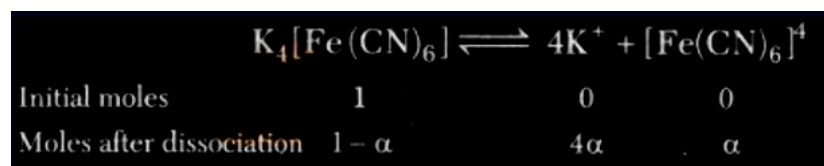

$$\text{Total moles at equilibrium} = 1 - \alpha + 4\alpha + \alpha$$

$$\text{Total} = 1 + 4\alpha$$

$$\therefore \text{van't Hoff factor } (i) = \frac{1+4\alpha}{1} = 1 + 4 \times 0.5 = 3$$

$$\text{Osmotic pressure, } \pi = iCRT$$

$$C = 0.1\text{M} = 10^2 \text{ mol m}^{-3}$$

$$\begin{aligned} \pi &= 3 \times 10^2 \times 8.314 \times 300 \\ &= 7.483 \times 10^5 \text{ Nm}^{-2} \end{aligned}$$

or

$$\pi = 7.48 \text{ atm}$$

46. 58.5 g of NaCl and 180 g of glucose were separately dissolved in 1000 mL of water. Identify the correct statement regarding the elevation of boiling point of the resulting solution.

- A. NaCl solution will show higher elevation of boiling point.
- B. Glucose solution will show higher elevation of boiling point.
- C. Both the solution will show equal elevation of boiling point.
- D. None will show boiling point elevation.

Ans. A

Solution:

$$58.5 \text{ gNaCl} = \frac{58.5}{58.5} \text{ mol}$$

$$= 1 \text{ mol}$$

$$180 \text{ g of glucose} = \frac{180}{180} = 1 \text{ mol}$$

Thus, we have 1 M NaCl and 1 M glucose solution.

But NaCl dissociates in the solution and glucose does not dissociates.

Thus particle concentration is more in NaCl .

Hence, NaCl solution will have higher elevation in boiling point.

47. One molar concentration of a solution represents :

- A. 1 mole of solute in 1 kg of solution.
- B. 1 mole of solute in 1 L of solution.
- C. 1 mole of solvent in 1 kg of solution.
- D. 1 mole of solvent in 1 L of solution.

Ans. B

Solution:

1M = 1 mole of solute in 1 L solution.

48. Which of the following substances show the highest colligative properties?

- A. 0.1M BaCl_2
- B. 0.1M AgNO_3
- C. 0.1 M urea
- D. 0.1M $(\text{NH}_4)_3\text{PO}_4$

Ans. D

Solution:

Colligative property depends on the number of particles or ions. Option (d) consists 4 of ions due to which it shows highest colligative property.

49. The pH of 0.5 L of 1.0 M NaCl solution after electrolysis for 965 s using 5.0 A current is,

- A. 1.0
- B. 12.7
- C. 1.30
- D. 13.0

Ans. D

Solution:

The reaction involved is,

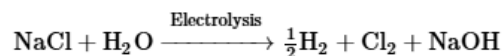

Amount of NaCl present in 0.5 L of 1.0M, $\text{NaCl} = 0.5 \text{ mol}$

Quantity of electricity passed = 965×5 coulombs.

\therefore 4825 coulombs will decompose NaCl .

$$\begin{aligned} &= \frac{4825}{96500} \text{ mol} \\ &= 0.05 \text{ mol} \end{aligned}$$

NaOH formed in the solution will also be 0.05 mol .

Volume of solution = 0.5 L

\therefore Molarity of NaOH in the solution

$$\begin{aligned} &= \frac{0.05 \text{ moles}}{0.5 \text{ L}} = 0.1 \text{ M} \\ &= 10^{-1} \text{ M} \end{aligned}$$

$$\begin{aligned} \therefore \quad &\text{pOH} = 1 \\ \text{or } &\text{pH} = 14 - 1 = 13 \end{aligned}$$

50. Calculate the molarity of a solution containing 5 g of NaOH dissolved in the product of H₂ – O₂ fuel cell operated at 1 A current for 595.1 hours. (Assume F = 96500C/mol of electron and molecular weight of NaOH as 40 g mol⁻¹).

- A. 0.625 M
- B. 0.05 M
- C. 0.1 M
- D. 6.25 M

Ans. A

Solution:

The overall reaction of H₂ – O₂ fuel is,

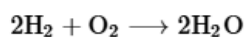

Thus $4F = 4 \times 96500\text{C}$ produce water = 2 mol = 36 g

$$\begin{aligned}\text{Charge actually passed} &= i \times t \\ &= 1 \times 595.1 \times 60 \times 60 \\ &= 2142360\text{C}\end{aligned}$$

$$\begin{aligned}\therefore \text{Water produced} &= \frac{36}{4 \times 96500} \times 2142360 \\ &\cong 200 \text{ g or } 200 \text{ mL}\end{aligned}$$

$$\begin{aligned}\therefore \text{Molarity of NaOH solution} &= \frac{5}{40} \times \frac{1}{200} \times 1000 \\ &= 0.625\text{M}\end{aligned}$$

51. When the same quantity of electricity is passed through the aqueous solutions of the given electrolytes for the same amount of time, which metal will be deposited in maximum amount on the cathode?

- A. ZnSO₄
- B. FeCl₃
- C. AgNO₃
- D. NiCl₂

Ans. C

Solution:

$$\frac{\text{Mass of metal}_1 \text{ deposited}}{\text{Mass of metal}_2 \text{ deposited}} = \frac{\text{Eq. wt. of metal}_1}{\text{Eq. wt. of metal}_2}$$

The equivalent weight of silver is highest among the given options.

52. For the reaction $2\text{SO}_2 + \text{O}_2 \rightleftharpoons 2\text{SO}_3$, the rate of disappearance of O_2 is $2 \times 10^{-4} \text{ mol L}^{-1} \text{ s}^{-1}$. The rate appearance of SO_3 is

- A. $2 \times 10^{-4} \text{ mol L}^{-1} \text{ s}^{-1}$
- B. $4 \times 10^{-4} \text{ mol L}^{-1} \text{ s}^{-1}$
- C. $1 \times 10^{-1} \text{ mol L}^{-1} \text{ s}^{-1}$
- D. $6 \times 10^{-4} \text{ mol L}^{-1} \text{ s}^{-1}$

Ans. B

Solution:

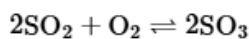

$$\text{Rate of reaction} = -\frac{1}{2} \frac{d[\text{SO}_2]}{dt} = -\frac{d[\text{O}_2]}{dt} = \frac{1}{2} \frac{d[\text{SO}_3]}{dt}$$

Rate of appearance of SO_3 ,

$$\begin{aligned} \frac{d[\text{SO}_3]}{dt} &= 2 \times \left[\frac{-d[\text{O}_2]}{dt} \right] = 2 \times (2 \times 10^{-4}) \\ &= 4 \times 10^{-4} \text{ mol L}^{-1} \text{ s}^{-1} \end{aligned}$$

53. If for a first order reaction, the value of A and E_a are $4 \times 10^{13} \text{ s}^{-1}$ and 98.6 kJ mol^{-1} respectively, then at what temperature will its half life period be 10 minutes?

- A. 330 K
- B. 300 K
- C. 330.95 K
- D. 311.15 K

Ans. D

Solution:

According to Arrhenius equation,

$$\log k = \log A - \frac{E_a}{2.303RT} \dots (i)$$

For 1st order reaction,

$$k = \frac{0.693}{t_{1/2}} = \frac{0.693}{600s} = 1.1 \times 10^{-3} \text{ s}^{-1}$$

Substitute the value of k in Eq. (i)

$$\log(1.1 \times 10^{-3}) = \log(4 \times 10^{13}) - \frac{98.6 \times 10^3}{2.303 \times 8.314 \times T}$$

Solving for T ,

$$T = 311.15 \text{ K}$$

54. In the chemical reaction $A \rightarrow B$, what is the order of the reaction? Given that, the rate of reaction doubles if the concentration of A is increased four times.

A. 2

B. 1.5

C. 0.5

D. 1

Ans. C

Solution:

$$\text{We know, } r_1 = k[A]^n \dots (i)$$

If conc. of A is increased four times rate of reaction on doubles.

$$2r_1 = k[4A]^n \dots (ii)$$

Divide Eq. (ii) by (i).

$$\frac{2r_1}{r_1} = \frac{k(4A)^n}{k(A)^n}$$

$$\Rightarrow 2 = (4)^n \Rightarrow 2n = (2)^{2n} \Rightarrow n = 0.5$$

55. Calculate the activation energy of a reaction, whose rate constant doubles on raising the temperature from 300 K to 600 K .

A. 3.45 kJ/mol

B. 6.90 kJ/mol

C. 9.68 kJ/mol

D. 19.6 kJ/mol

Ans. A

Solution:

$$\log\left(\frac{k_2}{k_1}\right) = \frac{E_a}{2.303R} \left[\frac{1}{T_1} - \frac{1}{T_2} \right]$$

$$\text{or, } \log\left(\frac{2k}{k}\right) = \frac{E_a}{2.303 \times 8.3} \times \frac{[600 - 300]}{300 \times 600}$$

$$E_a \approx 3.45 \text{ kJ/mol}$$

56. In the reaction, $A \rightarrow \text{products}$, If the concentration of the reactant is doubled rate of the reaction remains unchanged. The order of the reaction with respect to A is

A. 1

B. 2

C. 0.5

D. 0

Ans. D

Solution:

$$r_1 = k[A]^n \text{ and } r_2 = k[2A]^n$$

$$\therefore r_1 = r_2 \quad \therefore k[A]^n = k(2[A])^n$$

$$\text{or, } 2^n = 1$$

$$\text{or, } 2^n = 2^0 \Rightarrow n = 0$$

It is a zero order reaction.

57. In a first order reaction, the concentration of the reactant, decreases from 0.8 M to 0.4 M in 15 minutes. The time taken for the concentration to change from 0.1 M to 0.025 M is

A. 7.5 minutes

B. 15 minutes

C. 30 minutes

D. 60 minutes

Ans. C

Solution:

As the concentration of reactant decreases from 0.8 to 0.4 in 15 minutes, hence the $t_{1/2}$ is 15 minutes. To fall the concentration from 0.1 to 0.025, we need two half lives, i.e., 30 minutes.

58. The charge on colloidal particles is due to

A. presence of electrolyte

B. very small size of particles

C. adsorption of ions from the solution

D. can't be determined

Ans. C

Solution:

The colloidal particles have a tendency to preferentially adsorb a particular type of ions from the solution. This preferential adsorption of a particular type of ions imparts a particular type of charge to colloidal particles.

59. The chemical composition of 'slag' formed during the smelting process in the extraction of copper is

A. $\text{Cu}_2\text{O} + \text{FeS}$

B. FeSiO_3

C. CuFeS_2

D. $\text{Cu}_2\text{S} + \text{FeO}$

Ans. B

Solution:

During the extraction of copper, iron is present in the ore as impurity (FeS).

The ore together with a little coke and silica is smelted; FeS present as impurity in the ore is oxidized to iron oxide, which then reacts with silica to form fusible ferrous silicate which is removed as slag.

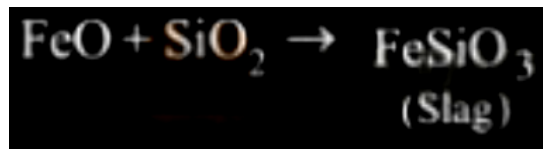
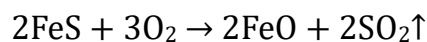

60. Calamine, malachite, magnetite and cryolite, respectively, are

- A. ZnCO_3 , $\text{CuCO}_3 \cdot \text{Cu}(\text{OH})_2$, Fe_3O_4 , Na_3AlF_6
- B. ZnSO_4 , $\text{Cu}(\text{OH})_2$, Fe_3O_4 , Na_3AlF_6
- C. ZnSO_4 , CuCO_3 , Fe_2O_3 , AlF_3
- D. ZnCO_3 , CuCO_3 , Fe_2O_3 , Na_3AlF_6

Ans. A

Solution:

Calamine $\rightarrow \text{ZnCO}_3$

Malachite $\rightarrow \text{CuCO}_3 \cdot \text{Cu}(\text{OH})_2$

Magnetite $\rightarrow \text{Fe}_3\text{O}_4$

Cryolite $\rightarrow \text{Na}_3\text{AlF}_6$

61. In which of the following molecules, all bond lengths are not equal?

- A. SF_6
- B. PCl_5
- C. BCl_3
- D. CCl_4

Ans. B

Solution:

In PCl_5 bond length of axial bond is greater than the length of equatorial bond.

62. The sol formed in the following unbalanced equation is

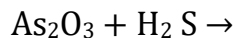

A. As_2S_2

B. As_2S_3

C. As

D. S

Ans. B

Solution:

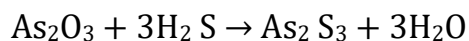

63. Which of the following has least tendency to liberate H₂ from mineral acids?

A. Cu

B. Mn

C. Ni

D. Zn

Ans. A

Solution:

In reactivity series, Cu lies below Hydrogen and it is least electropositive among the given metals.

64. The metal that shows highest and maximum number of oxidation state is:

A. Fe

B. Mn

C. Ti

D. Co

Ans. B

Solution:

Mn shows highest oxidation state of +7 in 3d series metals. Ti, Co and Fe shows highest. Oxidation state of +2, +4 and +6 respectively. Oxidation state of +2, +4 and +6 respectively.

65. Hybridisation and geometry of $[\text{Ni}(\text{CN})_4]^{2-}$ are

- A. sp^3d and tetrahedral
- B. sp^3 and square planar
- C. sp^3 and tetrahedral
- D. dsp^2 and square planar

Ans. D

Solution:

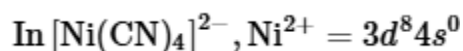

As CN^- is a strong ligand, pairing of electrons take place, Therefore,

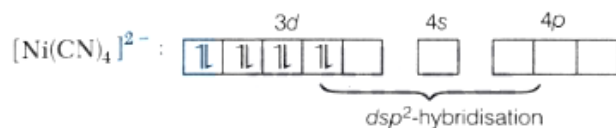

dsp^2 hybridisation gives square planar geometry.

66. Match List I with List II.

<i>List I</i> c (Complex)	<i>List II</i> c (Oxidation number of metal)
A. $\text{Ni}(\text{CO})_4$	I. +1
B. $[\text{Fe}(\text{H}_2\text{O})_5\text{NO}]^{2+}$	II. Zero
C. $[\text{Co}(\text{CO})_5]^{2-}$	III. -1
D. $[\text{Cr}_2(\text{CO})_{10}]^{2-}$	IV. -2

Choose the correct answer from the options given below:

- A. A-II, B-I, C-IV, D-III
- B. A-II, B-IV, C-I, D-III
- C. A-II, B-III, C-I, D-IV
- D. A-I, B-II, C-IV, D _ III

Ans. A

Solution:

The correct match is A-II, B-I, C-IV, D-III.

67. Which of the following is correct order of ligand field strength?

- A. $\text{CO} < \text{en} < \text{NH}_3 < \text{C}_2\text{O}_4^{2-} < \text{S}^{2-}$
- B. $\text{S}^{2-} < \text{C}_2\text{O}_4^{2-} < \text{NH}_3 < \text{en} < \text{CO}$
- C. $\text{NH}_3 < \text{en} < \text{CO} < \text{S}^{2-} < \text{C}_2\text{O}_4^{2-}$
- D. $\text{S}^{2-} < \text{NH}_3 < \text{en} < \text{CO} < \text{C}_2\text{O}_4^{2-}$

Ans. B

Solution:

The increasing order of field strength of ligands (according to spectrochemical series)

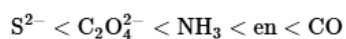

68. The correct statement among the following is;

- A. Ferrocene has two cyclohexadiene rings coordinated to iron atom.
- B. Ferrocene has two cyclopentadienyl anion rings bonded to iron (II) ion.
- C. Perxenate ion is $[\text{XeO}_2 \text{F}_2]^{2-}$
- D. Perxenate ion is tetrahedral in shape.

Ans. B

Solution:

Ferrocene is $\text{Fe}(\eta^5 - \text{C}_5\text{H}_5)_2$

Perxenate ion is $[\text{XeO}_6]^{4-}$ which is octahedral.

69. The type of isomerism present in nitropentammine chromium (III) chloride is

- A. optical
- B. linkage
- C. ionization

D. polymerisation.

Ans. B

Solution:

The chemical formula of nitropenta ammine chromium(III) chloride is:

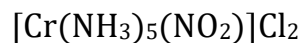

It can exist in following two structures

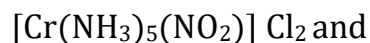

Pentaamminenitrochromium (III) chloride

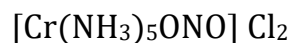

Pentaamminenitrochromium (III) chloride

Therefore, the type of isomerism found in this compound is linkage isomerism as NO_2 group is linked through N as $-\text{NO}_2$ or through O as ONO .

70. Identify, from the following, the diamagnetic, tetrahedral complex

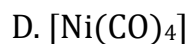
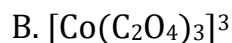
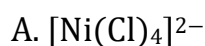

Ans. D

Solution:

(a) Ni in $[\text{Ni}(\text{Cl})_4]^{2-}$ exist as Ni^{2+} ion.

Cl is a weak field ligand (high spin). It will not cause pairing of electrons.

Hence, configuration of $[\text{Ni}(\text{Cl})_4]^{2-}$ is

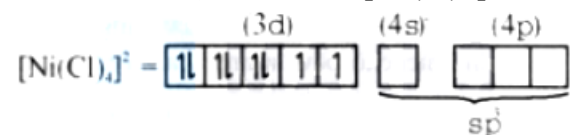

Tetrahedral with two unpaired electrons (i.e., paramagnetic) and has sp^3 hybridisation.

(b) In $[\text{Co}(\text{C}_2\text{O}_4)_3]^{3-}$, $(\text{C}_2\text{O}_4)_3^{2-}$ is a bidentate ligand thus, give octahedral structure.

(c) In $[\text{Ni}(\text{CN})_4]^{2-}$, Ni exist as Ni^{2+} ion.

CN^- is a strong field ligand (low spin). Causes pairing of electrons of 3d orbital.

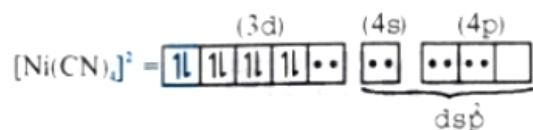

Hence, the structure of is square planar and it is diamagnetic.

(d) In $[\text{Ni}(\text{CO})_4]$, Ni has zero oxidation state. i.e.,



CO is a strong field ligand causes rearrangement and pairing of electrons of 3d and 4s orbital.



Structure of $\text{Ni}(\text{CO})_4$ is tetrahedral with sp^3 hybridisation and it is diamagnetic.

Hence, (4) is the correct answer.

71. Ferrocene is:

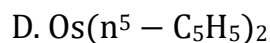
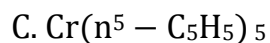
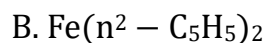
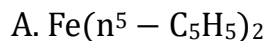

Ans. A

Solution:

Ferrocene has two cyclopentadienyl rings coordinated to an Fe^{2+} ion. The hapticity of each ring is 5 .

72. The chemical name of calgon is

A. Sodium hexametaphosphite

B. Potassium hexametaphosphate

C. Calcium hexametaphosphate

D. Sodium hexametaphosphate

Ans. D

Solution:

Calgon is sodium hexametaphosphate with the formula $\text{Na}_6\text{P}_6\text{O}_{18}$:

73. The complex with highest magnitude of crystal field splitting energy (Δ_0) is

- A. $[\text{Cr}(\text{OH}_2)_6]^{3+}$
- B. $[\text{Ti}(\text{OH}_2)_6]^{3+}$
- C. $[\text{Fe}(\text{OH}_2)_6]^{3+}$
- D. $[\text{Mn}(\text{OH}_2)_6]^{3+}$

Ans. A

Solution:

smaller cations prefer coordinate bonding due to greater polarizing power. $\text{Ti}^{+3} = 67\text{pm}$ radius, $\text{Cr}^{3+} = 62\text{pm}$ radius $\text{Mn}^{+3} = 65\text{pm}$ radius, $\text{Fe}^{+3} = 65\text{pm}$ radius
So, Cr^{3+} has highest tendency to attract ligand.

74. IUPAC name of $[\text{Pt}(\text{NH}_3)_2\text{Cl}(\text{NH}_2\text{CH}_3)] \text{Cl}$ is

- A. (Amino methane) chloro (diammine) platinum (II) chloride.
- B. Chlorodiammine (methanamine) platinum(II) chloride.
- C. Diamminechloro(methanamine) platinum(II) chloride.
- D. Diamminechloro(methylamine) platinum(IV) chloride.

Ans. C

Solution:

The complex is a cationic complex with two ammine (NH_3), one chloro (Cl) and one methanamine ligand.

Thus, the name will be :Diamminechloro (methanamine) platinum (II) chloride.

75. Which of the following complexes will exhibit maximum attraction to an applied magnetic field?

- A. $[\text{Zn}(\text{H}_2\text{O})_6]^{2+}$
- B. $[\text{Co}(\text{H}_2\text{O})_6]^{2+}$

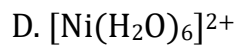
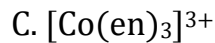

Ans. B

Solution:

Complex with maximum number of unpaired electron will exhibit maximum attraction to an applied magnetic field.

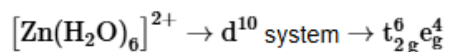

0 unpaired e^-

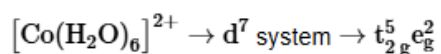

3 unpaired e^-

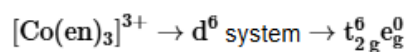

0 unpaired e^-

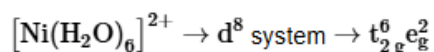

2 unpaired e^-

76. In S_N2 substitution reaction of the type

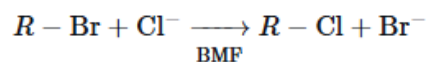

Which one of the following has highest relative rate?

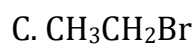
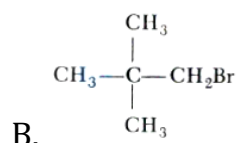
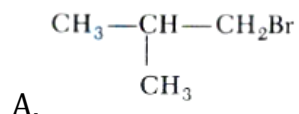

Ans. C

Solution:

The rate of S_N2 reaction is the maximum with 1° alkyl halide having least steric hindrance. Out of

$\text{CH}_3\text{CH}_2\text{Br}$ and $\text{CH}_3\text{CH}_2\text{CH}_2\text{Br}$, $\text{CH}_3\text{CH}_2\text{Br}$ has the least steric hindrance and hence has the highest relative rate.

77. The final product in following reaction Y is,

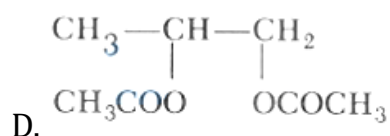
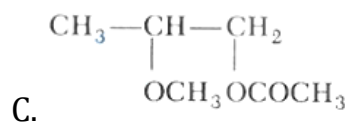
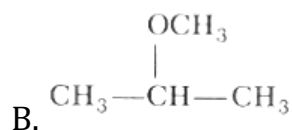
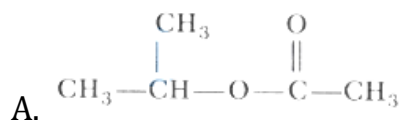
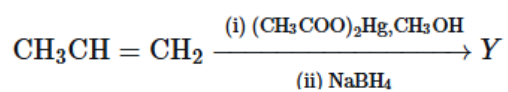

Ans. B

Solution:

The complete reaction is as follows,

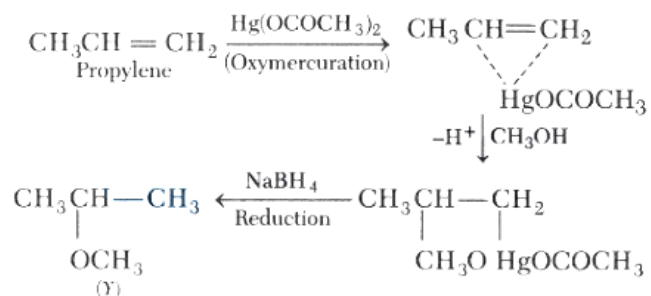

78. In the Victor-Meyer's test, the colour given by 1°, 2° and 3° alcohols are respectively:

- A. Red, colourless, blue
- B. Red, blue, colourless
- C. Colourless, red, blue
- D. Red, blue, violet

Ans. B

Solution:

Victor Meyer's test: The various steps involved are

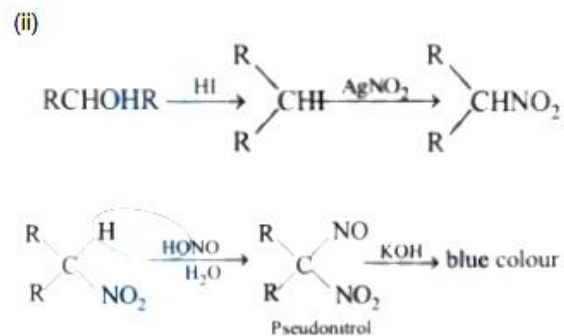
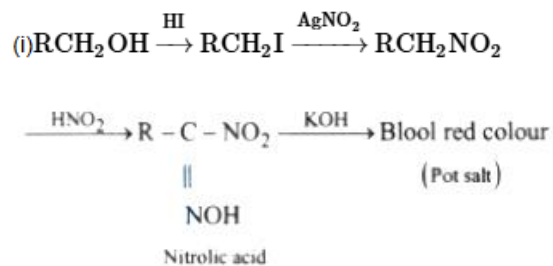

(iii)

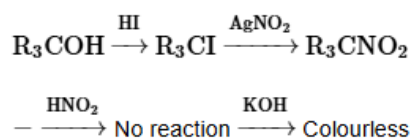

79. What is X in the following reaction?

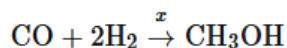

A. 623 K/300 atm

B. $\text{KMnO}_4/\text{H}^\oplus$

C. Zn/Δ

D. $\text{ZnO} - \text{Cr}_2\text{O}_3$, 200 – 300 atm, 573 – 673 K

Ans. D

Solution:

The given reaction is for the industrial preparation methanol from a mixture of carbon monoxide and hydrogen. In the reaction the gaseous mixture is subjected to 200 atmosphere and then passed over heated catalyst mixture of ZnO and Cr_2O_3 kept at 573 – 673 K. This reaction results the formation of methanol vapours which are then condensed to liquid state.

80. An unknown alcohol is treated with the "Lucas reagent" to determine whether the alcohol is primary, secondary or tertiary. Which alcohol reacts fastest and by what mechanism :

A. secondary alcohol by $\text{S}_{\text{N}}1$

B. tertiary alcohol by $\text{S}_{\text{N}}1$

C. secondary alcohol by $\text{S}_{\text{N}}2$

D. tertiary alcohol by $\text{S}_{\text{N}}2$

Ans. B

Solution:

The reaction of alcohol with Lucas reagent is mostly an $\text{S}_{\text{N}}1$ mechanism reaction and the rate of reaction is directly proportional to the carbocation stability formed in the reaction, hence tertiary alcohol will react fastest.

81. Which of the following compounds will undergo self aldol condensation in the presence of cold dilute alkali?

- A. $\text{CH}_2 = \text{CH} - \text{CHO}$
- B. $\text{CH} \equiv \text{C} - \text{CHO}$
- C. $\text{C}_6\text{H}_5\text{CHO}$
- D. $\text{CH}_3\text{CH}_2\text{CHO}$

Ans. D

Solution:

Aldehydes which contain α -hydrogen on a saturated carbon, i.e. $\text{CH}_3\text{CH}_2\text{CHO}$ will undergo aldol condensation.

Although $\text{CH}_2 = \overset{\alpha}{\text{C}}\text{H} - \text{CHO}$ also contain a α -hydrogen atom but cannot be easily abstracted by a base to form a carbanion and hence does not undergo aldol condensation.

82. An alkene X on ozonolysis gives a mixture of Propan-2-one and methanal. What is X?

- A. Propene
- B. 2-Methylpropene
- C. 2-Methylbut-1-ene
- D. 2-Methylbut-2-ene

Ans. B

Solution:

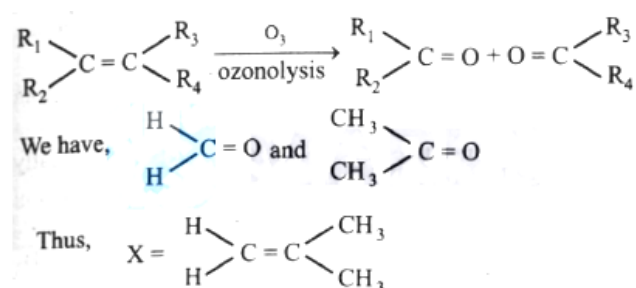

83. Cheilosis and digestive disorders are due to deficiency of

- A. Vitamin A

- B. Thiamine
- C. Riboflavin
- D. Ascorbic acid

Ans. C

Solution:

Deficiency of riboflavin (vitamin B₂) can cause cheilosis and digestive disorder.

84. A tetrapeptide is made of naturally occurring alanine, serine, glycine and valine. If the C-terminal amino acid is alanine and N-terminal amino acid is chiral, the number of possible sequence of the tetrapeptide is

- A. 4
- B. 8
- C. 6
- D. 12

Ans. A

Solution:

Since glycine (gly) is achiral, alanine (Ala) is the C-terminal amino acid, therefore N-terminal amino acid can be valine (val) or serine (ser). In the view of these condition, the following four sequences for the tetrapeptide is possible.

- (i) Val-gly-Ser-Ala
- (ii) Val-Ser-gly-Ala
- (iii) Ser-gly-Val-Ala
- (iv) Ser-Val-gly-Ala

85. Which one of the following is a water soluble vitamin, that is not excreted easily?

- A. Vitamin B₂
- B. Vitamin B₁
- C. Vitamin B₆
- D. Vitamin B₁₂

Ans. D

Solution:

B group vitamins and vitamin C are soluble in water except vitamin B₁₂ all are excreted easily.

86. Glycosidic linkage between C₁ of α-glucose and C₂ of β-fructose is found in

- A. maltose
- B. sucrose
- C. lactose
- D. amylose

Ans. B

Solution:

- Maltose is composed of two glucose units.
- Sucrose has glycosidic linkage between C₁ of α-glucose and C₂ of β-fructose.
- Lactose is composed of galactose and glucose
- Amylose has glycosidic linkage between C₁ of α-glucose C₄ of α-glucose.

87. The naturally occurring amino acid that contains only one basic functional group in its chemical structure is

- A. arginine
- B. lysine
- C. asparagine
- D. histidine

Ans. C

Solution:

Asparagine has only one basic functional group in its chemical structure.

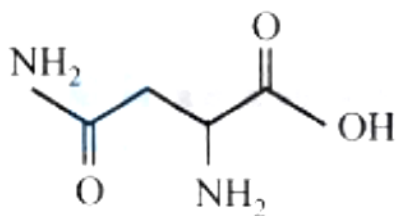

Others are basic amino acid with more than one basic functional group.

88. Which of the following is not a semi-synthetic polymer?

- A. Cis-polyisoprene
- B. Cellulose nitrate
- C. Cellulose acetate
- D. Vulcanised rubber

Ans. A

Solution:

cis-polyisoprene is natural rubber.

89. Zinc acetate - antimony trioxide catalyst used in the preparation of which polymer?

- A. High density polythene
- B. Teflon
- C. Terylene
- D. PVC

Ans. C

Solution:

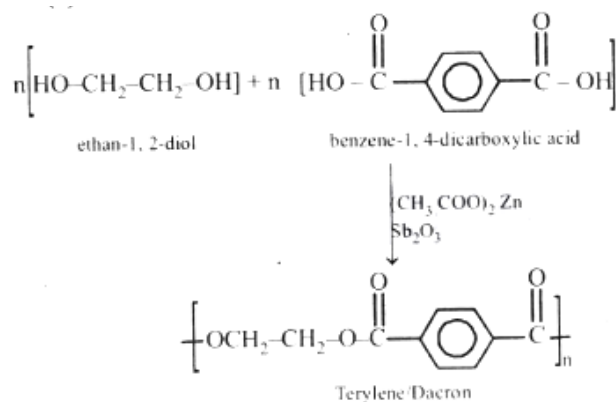

90. is a potent vasodilator.

- A. Histamine

- B. Serotonin
- C. Codeine
- D. Cimetidine

Ans. A

Solution:

Histamine is a potent vasodilator. It contracts smooth muscles and relaxes other muscles of blood vessels of stomach walls. In stomach, histamine stimulates the secretion of hydrochloric acid and pepsin.

Mathematics

1. Roots of the equation $x^2 + bx - c = 0$ ($b, c > 0$) are

- A. both positive
- B. both negative
- C. of opposite sign
- D. None of the above

Ans. C

Solution:

We know that, if roots are of same sign \Rightarrow Product of root is + ve if roots are of opposite sign \Rightarrow Product of roots is -ve Here, $x^2 + bx - c = 0$ ($b, c > 0$)

Product of roots = $-c/1 = -ve$

\therefore Roots are of opposite sign.

2. Rational roots of the equation $2x^4 + x^3 - 11x^2 + x + 2 = 0$ are

- A. $1/2$ and 2
- B. $\frac{1}{2}, 2, \frac{1}{4}, -2$
- C. $\frac{1}{2}, 2, 3, 4$
- D. $\frac{1}{2}, 2, \frac{3}{4}, -2$

Ans. A

Solution:

Given equation can be reduced to a quadratic equation.

$$\therefore 2x^2 + x - 11 + \frac{1}{x} + \frac{2}{x^2} = 0$$

$$\Rightarrow 2\left(x^2 + \frac{1}{x^2}\right) + \left(x + \frac{1}{x}\right) - 11 = 0$$

$$\text{Put } x + \frac{1}{x} = y$$

$$2(y^2 - 2) + y - 11 = 0$$

$$\Rightarrow 2y^2 + y - 15 = 0$$

$$\Rightarrow y = -3 \text{ and } \frac{5}{2}$$

$$\Rightarrow x + \frac{1}{x} = -3, x + \frac{1}{x} = \frac{5}{2}$$

$$\Rightarrow x^2 + 3x + 1 = 0, 2x^2 - 5x + 2 = 0$$

Only 2nd equation has rational roots as $D = 9$ and roots are $\frac{1}{2}$ and 2.

3. If $\tan 15^\circ$ and $\tan 30^\circ$ are the roots of the equation

$x^2 + px + q = 0$, then $pq =$

A. $\frac{6\sqrt{3}+10}{\sqrt{3}}$

B. $\frac{10-6\sqrt{3}}{3}$

C. $\frac{10+6\sqrt{3}}{3}$

D. $\frac{10-6\sqrt{3}}{\sqrt{3}}$

Ans. B

Solution:

$$\therefore \tan 15^\circ = \tan(45 - 30)^\circ = \frac{\sqrt{3}-1}{\sqrt{3}+1}$$

$$\therefore \tan 15^\circ + \tan 30^\circ = -p$$

$$\Rightarrow p = \frac{-4}{\sqrt{3}(\sqrt{3}+1)}$$

$$q = \tan 15^\circ \times \tan 30^\circ$$

$$= \frac{\sqrt{3}-1}{\sqrt{3}(\sqrt{3}+1)} \Rightarrow q = \frac{\sqrt{3}-1}{\sqrt{3}(\sqrt{3}+1)}$$

$$\therefore p \cdot q = \frac{-4}{\sqrt{3}(\sqrt{3}+1)} \times \frac{(\sqrt{3}-1)}{\sqrt{3}(\sqrt{3}+1)}$$

$$\Rightarrow p \cdot q = \frac{-4(\sqrt{3}-1)}{3(\sqrt{3}+1)^2} = \frac{10-6\sqrt{3}}{3}$$

$$\Rightarrow p \cdot q = \frac{10-6\sqrt{3}}{3}$$

\Rightarrow Option (2) is correct.

4. The points represented by the complex number $1 + i$, $-2 + 3i$, $5/3i$ on the argand plane are

- A. Vertices of an equilateral triangle
- B. Vertical of an isosceles triangle
- C. Collinear
- D. None of the above

Ans. C

Solution:

According to question,

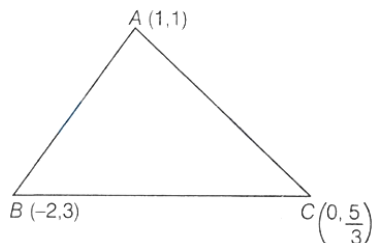

Let find slope of AB , BC and CA

$$\text{Slope of } AB = \frac{1-3}{1-(-2)} = \frac{-2}{3}$$

$$\text{Slope of } BC = \frac{3-\left(\frac{5}{3}\right)}{-2-0} = \frac{-2}{3}$$

$$\text{Slope of } CA = \frac{\frac{5}{3}-1}{0-1} = \frac{-2}{3}$$

Since, slope of all lines are same, therefore, points are collinear.

5. The modulus of the complex number z such that $|z + 3 - i| = 1$ and $\arg(z) = \pi$ is equal to

- A. 3
- B. 2
- C. 9
- D. 4

Ans. A

Solution:

Let $z = x + iy$

Given, $|z + 3 - i| = 1$

$$\Rightarrow |(x + 3) + (y - 1)i| = 1$$

$$\Rightarrow \sqrt{(x + 3)^2 + (y - 1)^2} = 1$$

$$\Rightarrow (x + 3)^2 + (y - 1)^2 = 1 \dots (i)$$

Above is the equation of circle with centre $\equiv (-3, 1)$ and

radius = 1

Also, $\arg(z) = \pi \Rightarrow \tan^{-1}\left|\frac{y}{x}\right| = \pi$

$$\Rightarrow \left|\frac{y}{x}\right| = \tan \pi = 0 \Rightarrow y = 0$$

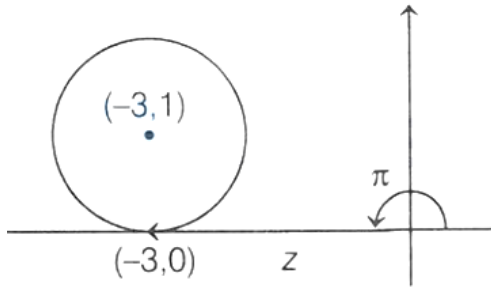

By Eq. (i),

$$\Rightarrow x = -3$$

$$\therefore z = -3 + 0i$$

$$\Rightarrow \text{Modulus of } z = 3$$

6. If $z, \bar{z}, -z, -\bar{z}$ forms a rectangle of area $2\sqrt{3}$ square units, then one such z is

A. $1/2 + \sqrt{3}i$

B. $\frac{\sqrt{5} + \sqrt{3}i}{4}$

C. $\frac{3}{2} + \frac{\sqrt{3}i}{2}$

D. $\frac{\sqrt{3} + \sqrt{11}i}{2}$

Ans. A

Solution:

Let a complex number, $z = x + iy$

$$\Rightarrow \bar{z} = \bar{x} - iy$$

Then, vertices of rectangle for $z, \bar{z}, -z, -\bar{z}$ are $(x, y), (x, -y), (-x, -y), (-x, y)$

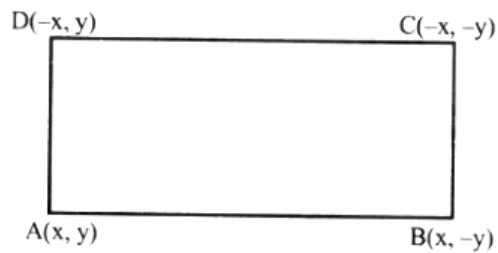

Now, Area of rectangle = $(2x)(2y) = 4xy$

It is given that,

$$\text{Area} = 2\sqrt{3} = 4xy \Rightarrow 2xy = \sqrt{3}$$

$$\therefore x = \frac{1}{2}, y = \sqrt{3} \quad \therefore z = \frac{1}{2} + \sqrt{3}i$$

7. If z_1, z_2, \dots, z_n are complex numbers such that $|z_1| = |z_2| = \dots = |z_n| = 1$, then $|z_1 + z_2 + \dots + z_n|$ is equal to

A. $|z_1 z_2 z_3 \dots z_n|$

B. $|z_1| + |z_2| + \dots + |z_n|$

C. $\left| \frac{1}{z_1} + \frac{1}{z_2} + \dots + \frac{1}{z_n} \right|$

D. n

Ans. C

Solution:

$$|z_1| = |z_2| = |z_3| = \dots = |z_n| = 1$$

$$\Rightarrow z_1 \bar{z}_1 = z_2 \bar{z}_2 = z_3 \bar{z}_3 = \dots = z_n \bar{z}_n = 1$$

$$\bar{z}_1 = \frac{1}{z_1}, \bar{z}_2 = \frac{1}{z_2}, \bar{z}_3 = \frac{1}{z_3}, \dots, \bar{z}_n = \frac{1}{z_n}$$

$$\text{Now, } |z_1 + z_2 + z_3 + \dots + z_n|$$

$$= |\bar{z}_1 + \bar{z}_2 + \dots + \bar{z}_n|$$

$$|\bar{z}_1 + \bar{z}_2 + \bar{z}_3 + \dots + \bar{z}_n| = \left| \frac{1}{z_1} + \frac{1}{z_2} + \frac{1}{z_3} + \dots + \frac{1}{z_n} \right|$$

8. If $|z_1| = 2, |z_2| = 3, |z_3| = 4$ and $|2z_1 + 3z_2 + 4z_3| = 4$, then absolute value of $8z_2z_3 + 27z_3z_1 + 64z_1z_2$ equals

A. 24

B. 48

C. 72

D. 96

Ans. D

Solution:

$$\begin{aligned} |8z_2z_3 + 27z_3z_1 + 64z_1z_2| &= |z_1| |z_2| |z_3| \\ \left| \frac{8}{z_1} + \frac{27}{z_2} + \frac{64}{z_3} \right| & \\ &= (2)(3)(4) \left| \frac{8\bar{z}_1}{|z_1|^2} + \frac{27\bar{z}_2}{|z_2|^2} + \frac{64\bar{z}_3}{|z_3|^2} \right| \\ &= 24 |2\bar{z}_1 + 3\bar{z}_2 + 4\bar{z}_3| \\ &= 24 |\overline{2z_1 + 3z_2 + 4z_3}| \\ &= 24 |2z_1 + 3z_2 + 4z_3| = (24)(4) = 96 \end{aligned}$$

9. A person invites a party of 10 friends at dinner and place so that 4 are on one round table and 6 on the other round table. Total number of ways in which he can arrange the guests is

- A. $10!/6!$
- B. $10!/24$
- C. $9!/24$
- D. None of these

Ans. B

Solution:

Total person = 10

Two groups are formed containing 4 and 6 persons.

\therefore Total ways of formation of groups = $10!/4!6!$

Now, 4 persons can be arranged on round table

$$= (4 - 1)! = 3$$

and 6 persons can be arranged on round table = $(6 - 1)!$

$$= 5!$$

\therefore Total ways of arranging the guest

$$= \frac{10!}{4!6!} \times 3! \times 5! = \frac{10!}{24}$$

10. How many different nine digit numbers can be formed from the number 223355888 by rearranging its digits so that the odd digits occupy even positions

- A. 16
- B. 36
- C. 60
- D. 100

Ans. C

Here we have 4 odd digits (3, 3, 5, 5) and 5 even digits (2, 2, 8, 8, 8).

$\bar{O}\bar{E}\bar{O}\bar{E}\bar{O}\bar{O}\bar{E}\bar{O}$

where, $E \rightarrow$ even place and $O \rightarrow$ odd place

\Rightarrow Number of ways odd digits will be place on even places

$$= \frac{4!}{2!2!}$$

Number of ways even digits will be place on odd places

$$= \frac{5!}{2!3!}$$

$$\therefore \text{Total number of ways} = \frac{4!}{2!2!} \times \frac{5!}{2!3!} = 60$$

11. If ${}^{22}P_{r+1} : {}^{20}P_{r+2} = 11 : 52$, then r is equal to

- A. 3
- B. 5
- C. 7
- D. 9

Ans. C

Solution:

$${}^{22}P_{r+1} : {}^{20}P_{r+2} = 11 : 52$$

$$\text{or } (21 - r)(20 - r)(19 - r) = 52 \times 2 \times 21$$

$$\Rightarrow (21 - r)(20 - r)(19 - r) = 14 \times 13 \times 12$$

$$\Rightarrow (21 - r)(20 - r)(19 - r) = (21 - 7)(20 - 7)(19 - 7)$$

$$\Rightarrow r = 7$$

12. At an election a voter may vote for any number of candidates not exceeding the number to be elected. If 4 candidates are to be elected out of the 12 contested in the election and voter votes for at least one candidate, then the number of way of selections

- A. 793
- B. 298
- C. 781
- D. 1585

Ans. A

Solution:

Total contested candidates = 12

4 candidates are to be elected and voter votes for at least one candidate then total number of ways of selections.

$$\begin{aligned} &= {}^{12}C_1 + {}^{12}C_2 + {}^{12}C_3 + {}^{12}C_4 \\ &= 12 + \frac{12 \times 11}{2 \times 1} + \frac{12 \times 11 \times 10}{3 \times 2 \times 1} + \frac{12 \times 11 \times 10 \times 9}{4 \times 3 \times 2 \times 1} \\ &= 12 + 66 + 220 + 495 = 793 \end{aligned}$$

13. The number of arrangements of all digits of 12345 such that at least 3 digits will not come in its position is

- A. 89
- B. 109
- C. 78

D. 57

Ans. B

Solution:

Total number of ways such that at least 3 digits will not come in its position

$$\begin{aligned} &= {}^5C_3 \{3! - {}^3C_1 2! + {}^3C_2 1! - {}^3C_3 0!\} \\ &+ {}^5C_4 \{4! - {}^4C_1 3! + {}^4C_2 2! - {}^4C_3 1! + {}^4C_4 0!\} \\ &+ {}^5C_4 \{5! - {}^5C_1 4! + {}^5C_2 3! - {}^5C_3 2! + {}^5C_4 1! - {}^5C_5 0!\} \\ &= 10(2) + 5(9) + (44) = 20 + 45 + 44 = 109 \end{aligned}$$

14. If $a > 0$, $b > 0$, $c > 0$ and a, b, c are distinct, then $(a + b)(b + c)(c + a)$ is greater than

A. $2(a + b + c)$

B. $3(a + b + c)$

C. $6abc$

D. $8abc$

Ans. D

Solution:

We know that $AM \geq GM \dots (i)$

Now, applying Eq. (i) in a and b

$$\Rightarrow \frac{a+b}{2} \geq \sqrt{ab} \dots (ii)$$

applying Eq. (i) in b and c

$$\Rightarrow \frac{b+c}{2} \geq \sqrt{bc} \dots (iii)$$

and applying Eq. (i) in c and a

$$\Rightarrow \frac{c+a}{2} \geq \sqrt{ca} \dots (iv)$$

By E'qs. (ii), (iii) and (iv)

$$\Rightarrow \frac{(a+b)(b+c)(c+a)}{8} \geq abc$$

$$\Rightarrow (a+b)(b+c)(c+a) \geq 8abc$$

15. If $\sum_{k=1}^n k(k+1)(k-1) = pn^4 + qn^3 + tn^2 + sn$ where p, q, t and s are constants, then the value of s is equal to

A. $-1/4$

B. $-1/2$

C. $1/2$

D. $1/4$

Ans. B

Solution:

$$\begin{aligned}\text{Let } S &= \sum_{k=1}^n k(k+1)(k-1) \\ &= \sum_{k=1}^n k^3 - k\end{aligned}$$

We know that

$$\sum_{r=1}^P r = \frac{P(P+1)}{2}$$

and

$$\sum_{r=1}^P r^3 = \left[\frac{P(P+1)}{2} \right]^2$$

$$\begin{aligned}S &= \left[\frac{n(n+1)}{2} \right]^2 - \left[\frac{n(n+1)}{2} \right] \\ &= \frac{n(n+1)}{2} \left[\frac{n(n+1)}{2} - 1 \right] \\ &= \left(\frac{n^2+n}{2} \right) \left[\frac{n^2+n-2}{2} \right] \\ &= \frac{n^4}{4} + \frac{n^3}{2} - \frac{n^2}{4} - \frac{n}{2} \dots (i)\end{aligned}$$

Now, by comparing $pn^4 + qn^3 + tn^2 + sn$ with Eq. (i),

$$S = -\frac{1}{2}$$

16. There are four numbers of which the first three are in GP and the last three are in AP, whose common difference is 6. If the first and the last numbers are equal, then two other numbers are

- A. -2,4
- B. -4,2
- C. 2,6
- D. None of the above

Ans. B

Solution:

Let 3 numbers in AP are $a, (a + 6), (a + 12)$

Also, first and last number out of 4 numbers are equal \therefore 4 numbers are $(a + 12), a, (a + 6), (a + 12)$

Also, given, first 3 numbers are in GP

$$\Rightarrow a^2 = (a + 12)(a + 6)$$

$$\Rightarrow a^2 = a^2 + 18a + 72$$

$$\Rightarrow a = -\frac{72}{18} = -4$$

\therefore 4 numbers are 8, -4, 2, 8

17. If $A = 1 + r^a + r^{2a} + r^{3a} + \dots \infty$ and $B = 1 + r^b + r^{2b} + r^{3b} + \dots \infty$, then a/b is equal to

A. $\log_B(A)$

B. $\log_{1-B}(1 - A)$

C. $\log_{\frac{B-1}{B}}\left(\frac{A-1}{A}\right)$

D. None of these

Ans. C

Solution:

$$A = \frac{1}{1-r^a} \Rightarrow 1 - r^a = \frac{1}{A} \Rightarrow r^a = 1 - \frac{1}{A} = \frac{A-1}{A}$$

$$B = \frac{1}{1-r^b} \Rightarrow 1 - r^b = \frac{1}{B} \Rightarrow r^b = 1 - \frac{1}{B} = \frac{B-1}{B}$$

$$\therefore a \log r = \log\left(\frac{A-1}{A}\right)$$

$$\text{and } b \log r = \log\left(\frac{B-1}{B}\right)$$

$$\therefore \frac{a}{b} = \frac{\log\left(\frac{A-1}{A}\right)}{\log\left(\frac{B-1}{B}\right)} = \log_{\frac{B-1}{B}}\left(\frac{A-1}{A}\right)$$

18. The sum of the infinite series

$1 + \frac{5}{6} + \frac{12}{6^2} + \frac{22}{6^3} + \frac{35}{6^4} + \frac{51}{6^5} + \frac{70}{6^6} + \dots$ is equal to:

A. $425/216$

B. $429/216$

C. $288/125$

D. $280/125$

Ans. C

Solution:

$$\text{Let } S = 1 + \frac{5}{6} + \frac{12}{6^2} + \frac{22}{6^3} + \frac{35}{6^4} + \dots \dots \dots \text{(i)}$$

$$\frac{S}{6} = \frac{1}{6} + \frac{5}{6^2} + \frac{12}{6^3} + \frac{22}{6^4} + \dots \dots \dots \text{(ii)}$$

On subtracting (i) from (ii)

$$\frac{5}{6}S = 1 + \frac{4}{6} + \frac{7}{6^2} + \frac{10}{6^3} + \frac{13}{6^4} + \dots$$

$$\frac{5}{36}S = \frac{1}{6} + \frac{4}{6^2} + \frac{7}{6^3} + \frac{10}{6^4} + \frac{13}{6^5} + \dots$$

on subtraction

$$\frac{25}{36}S = 1 + \frac{3}{6} + \frac{3}{6^2} + \frac{3}{6^3} + \dots = \frac{8}{5}$$

$$S = \frac{8}{5} \times \frac{36}{25} = \frac{288}{125}$$

19. If $\tan^{-1}\left[\frac{1}{1+1.2}\right] + \tan^{-1}\left[\frac{1}{1+2.3}\right] + \dots + \tan^{-1}\left[\frac{1}{1+n(n+1)}\right] = \tan^{-1}[x]$, then x is equal to

A. $\frac{1}{n+1}$

B. $\frac{n}{n+1}$

C. $\frac{1}{n+2}$

D. $\frac{n}{n+2}$

Ans. D

$$\begin{aligned}
&\text{Given } \tan^{-1}\left(\frac{1}{1+1.2}\right) + \tan^{-1}\left(\frac{1}{1+2.3}\right) + \dots \\
&+ \tan^{-1}\left(\frac{1}{1+n(n+1)}\right) = \tan^{-1}(x) \\
\Rightarrow &\tan^{-1}\left(\frac{2-1}{1+1.2}\right) + \tan^{-1}\left(\frac{3-2}{1+2.3}\right) + \dots \\
&+ \tan^{-1}\left(\frac{n+1-n}{1+n(n+1)}\right) = \tan^{-1}(x) \\
\Rightarrow &\tan^{-1}(2) - \tan^{-1}(1) + \tan^{-1}(3) - \tan^{-1}(2) + \dots \\
&+ \tan^{-1}(n+1) - \tan^{-1}(n) = \tan^{-1}(x) \\
\Rightarrow &\tan^{-1}(n+1) - \tan^{-1}(1) = \tan^{-1}(x) \\
\left\{ \because \tan^{-1}(A) - \tan^{-1}(B) = \tan^{-1}\left(\frac{A-B}{1+AB}\right) \right\} \\
\Rightarrow &\tan^{-1}\left(\frac{n}{n+2}\right) = \tan^{-1}(x) \Rightarrow x = \frac{n}{n+2}
\end{aligned}$$

20. If arithmetic mean of two distinct positive real number a and b ($a > b$) be twice their geometric mean, then $a : b =$

- A. $(2 + \sqrt{3}) : (2 - \sqrt{3})$
- B. $(2 + \sqrt{5}) : (2 - \sqrt{5})$
- C. $(2 + \sqrt{2}) : (2 - \sqrt{2})$
- D. None of these

Ans. A

Solution:

By the given condition,

$$\frac{a+b}{2} = 2\sqrt{ab} \Rightarrow a + b = 4\sqrt{ab}$$

$$\text{Now, } (a - b)^2 = (a + b)^2 - 4ab = 16ab - 4ab = 12ab$$

$$\therefore a - b = \sqrt{12ab} = 2\sqrt{3}\sqrt{ab}$$

(Taking + ve sign only as $a > b$)

$$\therefore \frac{a+b}{a-b} = \frac{4\sqrt{ab}}{2\sqrt{3}\sqrt{ab}} = \frac{2}{\sqrt{3}}$$

By componendo and dividendo,

$$\frac{2a}{2b} = \frac{2+\sqrt{3}}{2-\sqrt{3}} \text{ or } \frac{a}{b} = \frac{2+\sqrt{3}}{2-\sqrt{3}}$$

If $y = \tan^{-1} \frac{1}{x^2+x+1} + \tan^{-1} \frac{1}{x^2+3x+3}$

21. $+ \tan^{-1} \frac{1}{x^2+5x+7} + \dots$ to n terms, then $\frac{dy}{dx} =$

A. $\frac{1}{x^2+n^2} - \frac{1}{x^2+1}$

B. $\frac{1}{(x+n)^2+1} - \frac{1}{x^2+1}$

C. $\frac{1}{x^2+(n+1)^2} - \frac{1}{x^2+1}$

D. None of these

Ans. B

Solution:

Given, $y = \tan^{-1} \frac{1}{x^2+x+1}$

$+ \tan^{-1} \frac{1}{x^2+3x+3} + \tan^{-1} \frac{1}{x^2+5x+7} + \dots$

to n terms

$$= \tan^{-1} \left\{ \frac{1}{1+x(x+1)} \right\} + \tan^{-1} \left\{ \frac{1}{1+(x+1)(x+2)} \right\}$$

$$+ \tan^{-1} \left\{ \frac{1}{1+(x+2)(x+3)} \right\}$$

$$+ \dots + \tan^{-1} \left\{ \frac{1}{1+(x+(n-1))(x+n)} \right\}$$

$$= \tan^{-1} \left\{ \frac{(x+1)-x}{1+(x+1)x} \right\}$$

$$+ \tan^{-1} \left\{ \frac{(x+2)-(x+1)}{1+(x+2)(x+1)} \right\}$$

$$+ \tan^{-1} \left\{ \frac{(x+3)-(x+2)}{1+(x+3)(x+2)} \right\}$$

$$+ \dots + \tan^{-1} \left(\frac{(x+n)-(x+n-1)}{1+(x+n)(x+n-1)} \right)$$

$\therefore y = \{ \tan^{-1}(x+1) - \tan^{-1}(x) \}$

$$\begin{aligned}
 &+ \{ \tan^{-1}(x+2) - \tan^{-1}(x+1) \} \\
 &+ \{ \tan^{-1}(x+3) - \tan^{-1}(x+2) \} \\
 &+ \dots + \{ \tan^{-1}(x+n) - \tan^{-1}[x+(n-1)] \}
 \end{aligned}$$

So, $y = \tan^{-1}(x+n) - \tan^{-1}(x)$

On differentiating both sides w.r.t. x , we get

$$\frac{dy}{dx} = \frac{1}{1+(x+n)^2} - \frac{1}{1+x^2}$$

22. The coefficient of x^2 term in the binomial expansion of $\left(\frac{1}{3}x^{\frac{1}{2}} + x^{-\frac{1}{4}}\right)^{10}$ is

- A. 70/243
- B. 60/423
- C. 50/13
- D. None of these

Ans. A

Solution:

General term of given binomial expansion is

$$\begin{aligned}
 T_{r+1} &= {}^{10}C_r \left(\frac{1}{3}x^{\frac{1}{2}}\right)^{10-r} \left(x^{-\frac{1}{4}}\right)^r \\
 &= {}^{10}C_r \times \left(\frac{1}{3}\right)^{10-r} x^{\frac{10-r}{2} - \frac{r}{4}}
 \end{aligned}$$

We have to find coefficient of x^2

$$\frac{10-r}{2} - \frac{r}{4} = 2 \Rightarrow r = 4$$

$$\Rightarrow T_{4+1} = {}^{10}C_4 \left(\frac{1}{3}\right)^6 x^2$$

$$\begin{aligned}
 \therefore \text{Coefficient of } x^2 &= {}^{10}C_4 \left(\frac{1}{3}\right)^6 \\
 &= \frac{10 \times 9 \times 8 \times 7}{4 \times 3 \times 2 \times 1} \times \frac{1}{3^6} = \frac{70}{243}
 \end{aligned}$$

23. The coefficient of x^n in the expansion of $\frac{e^{7x} + e^x}{e^{3x}}$ is

A. $\frac{4^{n-1} + (-2)^n}{n!}$

B. $\frac{4^{n-1} + 2^n}{n!}$

C. $\frac{4^n + (-2)^n}{n!}$

D. $\frac{4^{n-1} + (-2)^{n-1}}{n!}$

Ans. C

Solution:

Given, $\frac{e^{7x} + e^x}{e^{3x}} \Rightarrow e^{4x} + e^{-2x}$

Series of $e^a = 1 + \frac{a}{1!} + \frac{a^2}{2!} + \frac{a^3}{3!} \dots$

$$\Rightarrow e^{4x} + e^{-2x} = \left(1 + \frac{4x}{1!} + \frac{(4x)^2}{2!} + \frac{(4x)^3}{3!} + \dots \right) + \left(1 + \frac{(-2x)}{1!} + \frac{(-2x)^2}{2!} + \dots \right)$$

Here, coefficient of

$$x^2 \equiv \frac{4^2}{2!} + \frac{(-2)^2}{2!}$$

$$x^3 \equiv \frac{4^3}{3!} + \frac{(-2)^3}{3!}$$

⋮

$$x^n = \frac{4^n}{n!} + \frac{(-2)^n}{n!}$$

24. The coefficient of the highest power of x in the expansion of

$$(x + \sqrt{x^2 - 1})^8 + (x - \sqrt{x^2 - 1})^8$$

A. 64

B. 128

C. 256

D. 512

Ans. C

Solution:

$$\begin{aligned} &\text{Since } (x + \sqrt{x^2 - 1})^8 + (x - \sqrt{x^2 - 1})^8 \\ &= 2 \left\{ {}^8C_0 x^8 + {}^8C_2 x^6 (x^2 - 1) + {}^8C_4 x^4 (x^2 - 1)^2 \right. \\ &\quad \left. + {}^8C_6 x^2 (x^2 - 1)^3 + {}^8C_8 x^0 (x^2 - 1)^4 \right\} \\ &\text{So coefficient of highest power of } x \\ &= 2 \{ {}^8C_0 + {}^8C_2 + {}^8C_4 + {}^8C_6 + {}^8C_8 \} \\ &= (1 + 1)^8 + (1 - 1)^8 = 2^8 = 256 \end{aligned}$$

25. If the 17th and the 18th terms in the expansion of $(2 + a)^{50}$ are equal, then the coefficient of x^{35} in the expansion of $(a + x)^{-2}$ is

- A. -35
- B. 3
- C. 36
- D. -36

Ans. D

Solution:

Given, 17th and 18th terms in the expansion $(2 + a)^{50}$ are equal

$$\begin{aligned} &\therefore T_{17} = T_{18} \\ &\Rightarrow {}^{50}C_{16} (2)^{34} (a)^{16} = {}^{50}C_{17} (2)^{33} (a)^{17} \\ &\Rightarrow a = \frac{{}^{50}C_{16}}{{}^{50}C_{17}} \times 2 = 1 \\ &\therefore \text{Now, coefficient of } x^{35} \text{ in the expansion} \\ &(1 + x)^{-2} = -36 \\ &\therefore \text{Coefficient of } x^r \text{ is } (r + 1) \text{ in } (1 - x)^{-2}. \end{aligned}$$

26. Let A, B and C are the angles of a triangle and $\tan A/2 = 1/3$, $\tan B/2 = 2/3$. Then, $\tan C/2$ is equal to

- A. 7/9

B. $\frac{2}{9}$

C. $\frac{1}{3}$

D. $\frac{2}{3}$

Ans. A

Solution:

$A + B + C = 180^\circ$ (Angle sum property of a triangle)

$$\Rightarrow A + B = 180^\circ - C$$

$$\Rightarrow \frac{A + B}{2} = 90^\circ - \frac{C}{2}$$

$$\Rightarrow \tan\left(\frac{A}{2} + \frac{B}{2}\right) = \tan\left(90^\circ - \frac{C}{2}\right)$$

$$\Rightarrow \frac{\tan A/2 + \tan B/2}{1 - \tan A/2 \tan B/2} = \cot C/2$$

$$\Rightarrow \frac{\frac{1}{3} + \frac{2}{3}}{1 - \frac{1}{3} \times \frac{2}{3}} = \cot C/2 \Rightarrow \frac{1}{1 - \frac{2}{9}} = \cot C/2$$

$$\Rightarrow \frac{9}{7} = \cot C/2 \Rightarrow \tan C/2 = 7/9$$

27. The sum of all values of x in $[0, 2\pi]$, for which $\sin x + \sin 2x + \sin 3x + \sin 4x = 0$ is equal to :

A. 8π

B. 11π

C. 12π

D. 9π

Ans. D

Solution:

$$\begin{aligned}
& (\sin x + \sin 4x) + (\sin 2x + \sin 3x) = 0 \\
\Rightarrow & 2 \sin \frac{5x}{2} \cdot \cos \frac{3x}{2} + 2 \sin \frac{5x}{2} \cdot \cos \frac{x}{2} = 0 \\
\Rightarrow & 2 \sin \frac{5x}{2} \left\{ \cos \frac{3x}{2} + \cos \frac{x}{2} \right\} = 0 \\
\Rightarrow & 2 \sin \frac{5x}{2} \{ 2 \cos x \cos \frac{x}{2} \} = 0 \\
2 \sin \frac{5x}{2} = 0 \Rightarrow & \frac{5x}{2} = 0, \pi, 2\pi, 3\pi, 4\pi, 5\pi, \dots \\
\Rightarrow & x = 0, \frac{2\pi}{5}, \frac{4\pi}{5}, \frac{6\pi}{5}, \frac{8\pi}{5}, 2\pi \\
\cos \frac{x}{2} = 0 \Rightarrow & \frac{x}{2} = \frac{\pi}{2} \Rightarrow x = \pi; \\
\cos x = 0 \Rightarrow & x = \frac{\pi}{2}, \frac{3\pi}{2} \\
\text{So, sum} = & 6\pi + \pi + 2\pi = 9\pi
\end{aligned}$$

28. Number of solutions of equations $\sin 9\theta = \sin \theta$ in the interval $[0, 2\pi]$ is

- A. 16
- B. 17
- C. 18
- D. 15

Ans. B

Solution:

Given, $\sin 9\theta = \sin \theta$
 $\Rightarrow \sin 9\theta - \sin \theta = 0$
 $\Rightarrow 2 \cos \left(\frac{9\theta + \theta}{2} \right) \sin \left(\frac{9\theta - \theta}{2} \right) = 0$
 $\left[\because \sin C - \sin D = 2 \cos \left(\frac{C + D}{2} \right) \sin \left(\frac{C - D}{2} \right) \right]$
 $\Rightarrow 2 \cos 5\theta \sin 4\theta = 0$
 $\Rightarrow \text{Either } \cos 5\theta = 0 \text{ or } \sin 4\theta = 0, \text{ also } \theta \in [0, 2\pi]$
 $\Rightarrow 5\theta = (2n + 1) \frac{\pi}{2}$
or $4\theta = n\pi$
 $\Rightarrow \theta = (2n + 1) \frac{\pi}{10}$ or $\theta = \frac{n\pi}{4}$
 $\therefore \theta = \frac{\pi}{10}, \frac{3\pi}{10}, \frac{\pi}{2}, \frac{7\pi}{10}, \frac{9\pi}{10}, \frac{11\pi}{10}, \frac{13\pi}{10}, \frac{3\pi}{2}, \frac{17\pi}{10}, \frac{19\pi}{10}$
or $0, \frac{\pi}{4}, \frac{\pi}{2}, \frac{3\pi}{4}, \pi, \frac{5\pi}{4}, \frac{3\pi}{2}, \frac{7\pi}{4}, 2\pi$
 $\therefore \text{Total number of solutions} = 17$
 $\left(\because \frac{\pi}{2} \text{ and } \frac{3\pi}{2} \text{ are common} \right)$

29. The range of $(8 \sin \theta + 6 \cos \theta)^2 + 2$ is

- A. (0,2)
- B. [2,102]
- C. $(-\infty, \infty)$
- D. (2,1)

Ans. B

Solution:

$$-10 \leq 8 \sin \theta + 6 \cos \theta \leq 10$$

$$\Rightarrow 0 \leq (8 \sin \theta + 6 \cos \theta)^2 \leq 100$$

$$\Rightarrow 2 \leq (8 \sin \theta + 6 \cos \theta)^2 + 2 \leq 102$$

30. The locus of the point of intersection of the lines $x = a \left(\frac{1-t^2}{1+t^2} \right)$ and $y = \frac{2at}{1+t^2}$ represent (t being a parameter)

- A. Circle
- B. Parabola
- C. Ellipse

D. Hyperbola

Ans. A

Solution:

$$\text{Given } x = a \left(\frac{1-t^2}{1+t^2} \right) \text{ and } y = \frac{2at}{1+t^2}$$

$$\text{Let } t = \tan \theta$$

$$\Rightarrow x = a \left(\frac{1 - \tan^2 \theta}{1 + \tan^2 \theta} \right)$$

$$\text{and } y = \frac{2a \tan \theta}{1 + \tan^2 \theta}$$

$$\Rightarrow x = a \cos 2\theta \text{ and } y = a \sin 2\theta$$

$$\Rightarrow \cos 2\theta = \frac{x}{a} \text{ and } \sin 2\theta = \frac{y}{a}$$

Squaring both sides, we get

$$\cos^2 2\theta = \frac{x^2}{a^2} \dots (i)$$

and

$$\sin^2 2\theta = \frac{y^2}{a^2} \dots (ii)$$

Adding Eqs. (i) and (ii), we get

$$\begin{aligned} \cos^2 2\theta + \sin^2 2\theta &= \frac{x^2}{a^2} + \frac{y^2}{a^2} \\ \Rightarrow x^2 + y^2 &= a^2 \end{aligned}$$

\therefore Locus is a circle having centre at origin and radius a.

31. If the straight line $2x + 3y - 1 = 0$, $x + 2y - 1 = 0$ and $ax + by - 1 = 0$ form a triangle with origin as orthocentre, then (a,b) is equal to

- A. (6,4)
- B. (-3,3)
- C. (-8,8)
- D. (0,7)

Ans. C

Here, point A is the intersection of line AB and AC so equation of line passing through A.

$$(x + 2y - 1) + \lambda(2x + 3y - 1) = 0 \dots(i)$$

This line passes through the orthocentre (0,0), then

$$-1 - \lambda = 0$$

$$\Rightarrow \lambda = -1$$

On substituting $\lambda = -1$ in Eq. (i), we get $x + y = 0$ as the equation of AD. Since $AD \perp BC$, therefore

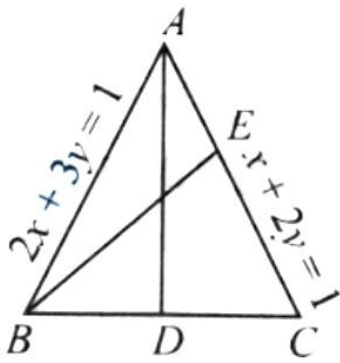

$$-1 \times -\frac{a}{b} = -1$$

$$\Rightarrow a + b = 0 \dots(ii)$$

Similarly, by applying the condition that BE is perpendicular to CA, we get $a + 2b = 8 \dots(iii)$

Now, solving Eqs. (ii) and (iii), we get $a = -8, b = 8$

33. The distance from the origin to the image of (1,1) with respect to the line $x + y + 5 = 0$ is

A. $7\sqrt{2}$

B. $3\sqrt{2}$

C. $6\sqrt{2}$

D. $4\sqrt{2}$

Ans. C

Solution:

As we know that the image of (1,1) with respect to line $x + y + 5 = 0$ is

$$\frac{x-1}{1} = \frac{y-1}{1} = \frac{2(1+1+5)}{1+1}$$

$$\Rightarrow x - 1 = -7, y - 1 = -7$$

$$\Rightarrow x = -6, y = -6$$

\therefore Image of point (1, 1) is (-6, -6) Now, distance from origin

This is the required transformed equation.

$$D = \sqrt{(0+6)^2 + (0+6)^2}$$

$$D = \sqrt{72} = 6\sqrt{2}$$

34. A(3,2,0), B(5,3,2), C(-9,6,-3) are three points forming a triangle. AD, the bisector of angle BAC meets BC in D. Find the co-ordinates of D.

A. $\frac{19}{8}, \frac{57}{15}, \frac{57}{15}$

B. $\frac{19}{8}, \frac{57}{16}, \frac{17}{16}$

C. (2,3,0)

D. (4,5,6)

Ans. B

Solution:

Since AD is the bisector of $\angle BAC$.

$$\Rightarrow \frac{BD}{DC} = \frac{AB}{AC} \dots(i)$$

Now,

$$AB = \sqrt{(5-3)^2 + (3-2)^2 + (2-0)^2}$$

$$= \sqrt{4+1+4} = \sqrt{9} = 3$$

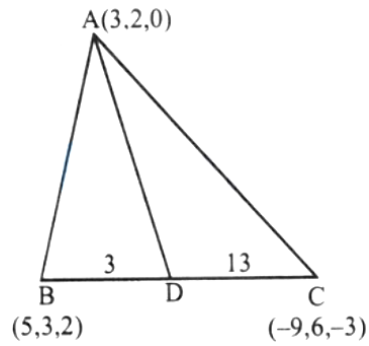

$$AC = \sqrt{(-9 - 3)^2 + (6 - 2)^2 + (-3 - 0)^2}$$

$$= \sqrt{144 + 16 + 9} = 13$$

$$\therefore \frac{BD}{DC} = \frac{3}{13}$$

Hence, D divides BC in the ratio 3 : 13

The co-ordinates of D are

$$\left(\frac{3(-9) + 13(5)}{3 + 13}, \frac{3(6) + 13(3)}{3 + 13}, \frac{3(-3) + 13(2)}{3 + 13} \right)$$

$$= \left(\frac{19}{8}, \frac{57}{16}, \frac{17}{16} \right)$$

35. The locus of the mid-point of a chord of the circle $x^2 + y^2 = 4$, which subtends a right angle at the origin is

A. $x + y = 2$

B. $x^2 + y^2 = 1$

C. $x^2 + y^2 = 2$

D. $x + y = 1$

Ans. C

Solution:

According to question,

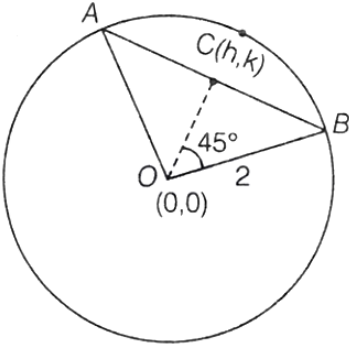

$$OC = \sqrt{h^2 + k^2}$$

In $\triangle OCB$,

$$\begin{aligned} \cos 45^\circ &= \frac{\sqrt{h^2 + k^2}}{2} \\ \Rightarrow \frac{\sqrt{h^2 + k^2}}{2} &= \frac{1}{\sqrt{2}} \\ \Rightarrow h^2 + k^2 &= 2 \end{aligned}$$

Replacing $h \rightarrow x$ and $k \rightarrow y$

$$\text{Locus} \Rightarrow x^2 + y^2 = 2$$

36. If p and q be the longest and the shortest distance respectively of the point $(-7,2)$ from any point (α,β) on the curve whose equation is $x^2 + y^2 - 10x - 14y - 51 = 0$, then G.M. of p

- A. $2\sqrt{11}$
- B. $5\sqrt{5}$
- C. 13
- D. 11

Ans. A

Solution:

The centre C of the circle = $(5,7)$ and the radius

$$= \sqrt{5^2 + 7^2 + 51} = 5\sqrt{5}$$

$$PC = \sqrt{12^2 + 5^2} = 13 \Rightarrow q = PA = 13 - 5\sqrt{5}$$

$$\text{and } p = PB = 13 + 5\sqrt{5}$$

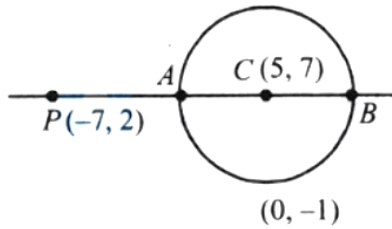

∴ G.M. of p and q

$$= \sqrt{pq} = \sqrt{(13 - 5\sqrt{5})(13 + 5\sqrt{5})}$$

$$= \sqrt{169 - 125} = 2\sqrt{11}.$$

37. From a point A(0,3) on the circle $(x + 2)^2 + (y - 3)^2 = 4$, a chord AB is drawn and it is extended to a point Q such that $AQ = 2AB$. Then the locus of Q is

A. $(x + 4)^2 + (y - 3)^2 = 16$

B. $(x + 1)^2 + (y - 3)^2 = 32$

C. $(x + 1)^2 + (y - 3)^2 = 4$

D. $(x + 1)^2 + (y - 3)^2 = 1$

Ans. A

Solution:

Given equation of circle

$$(x + 2)^2 + (y - 3)^2 = 4$$

Let the coordinates of Q is (h,k).

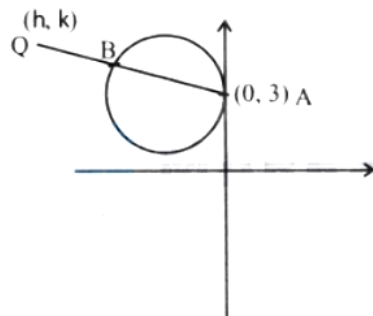

Coordinate of B which is midpoint of AQ because $AQ = 2AB$.

$$\text{Then, } B = \left(\frac{0+h}{2}, \frac{k+3}{2} \right) \rightarrow \left(\frac{h}{2}, \frac{k+3}{2} \right)$$

Point B also satisfy the equation of circle.

$$(x + 2)^2 + (y - 3)^2 = 4$$

$$\left(\frac{h}{2} + 2 \right)^2 + \left(\frac{k+3}{2} - 3 \right)^2 = 4$$

$$\frac{(h+4)^2}{4} + \frac{(k-3)^2}{4} = 4$$

$$(h + 4)^2 + (k - 3)^2 = 16$$

Replace (h, k) by (x, y) , then, the required equation is $(x + 4)^2 + (y - 3)^2 = 16$

38. If the focus of parabola $(y - k)^2 = 4(x - h)$ always lies between the lines $x + y = 1$ and $x + y = 3$ then

- A. $0 < h + k < 2$
- B. $0 < h + k < 1$
- C. $1 < h + k < 2$
- D. $1 < h + k < 3$

Ans. A

Solution:

Coordinate of focus will be $(h + 1, k)$

Now focus should lie to the opposite side of origin with respect to line $x + y - 1 = 0$ and same side as origin with respect to line $x + y - 3 = 0$

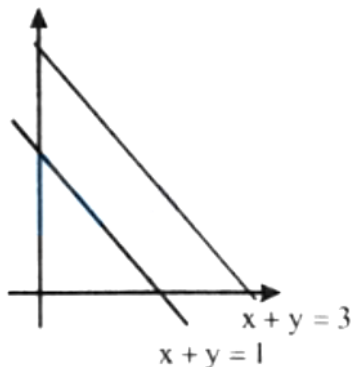

Hence $h + k > 0$ and $h + k < 2$.

39. Let L_1 be the length of the common chord of the curves $x^2 + y^2 = 9$ and $y^2 = 8x$, and L_2 be the length of the latus rectum of $y^2 = 8x$, then:

A. $L_1 > L_2$

B. $L_1 = L_2$

C. $L_1 < L_2$

D. $\frac{L_1}{L_2} = \sqrt{2}$

Ans. C

Solution:

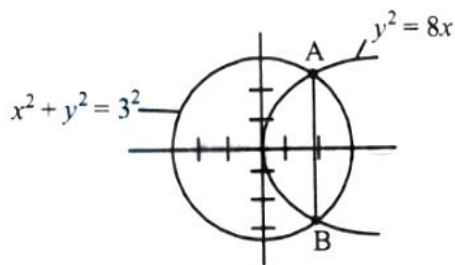

We have : $x^2 + (8x) = 9$

$\Rightarrow x^2 + 9x - x - 9 = 0$

$\Rightarrow x(x + 9) - 1(x + 9) = 0$

$\Rightarrow (x + 9)(x - 1) = 0 \Rightarrow x = -9, 1$

for $x = 1, y = \pm 2\sqrt{2x} = \pm 2\sqrt{2}$

$\sqrt{(2\sqrt{2} + 2\sqrt{2})^2 + (1 - 1)^2} = 4\sqrt{2}$

$L_n = \text{Length of latus rectum} = 4a = 4 \times 2 = 8$

$L_1 < L_2$

40. The foci of hyperbola $4x^2 - 9y^2 - 1 = 0$ are

A. $(\pm\sqrt{13}, 0)$

B. $(\pm\frac{\sqrt{13}}{6}, 0)$

C. $(0, \pm\frac{\sqrt{3}}{6})$

D. None of these

Ans. B

Solution:

$$\text{Given, Hyperbola} = 4x^2 - 9y^2 - 1 = 0$$

$$\Rightarrow \frac{x^2}{\left(\frac{1}{4}\right)} - \frac{y^2}{\left(\frac{1}{9}\right)} = 1$$

$$\Rightarrow \frac{x^2}{\frac{1}{2}} - \frac{y^2}{\frac{1}{3}} = 1$$

We know that, if hyperbola is $\frac{x^2}{a^2} - \frac{y^2}{b^2} = 1$, then Eccentricity:

$$e = \sqrt{1 + \frac{b^2}{a^2}}$$

$$\text{and focus} \equiv (\pm be, 0) = \left(\pm \frac{1}{2} \times \frac{\sqrt{1/3}}{3}, 0\right) = \left(\pm \frac{\sqrt{13}}{6}, 0\right)$$

41. Given a real valued function ' f ' such that

$$f(x) = \begin{cases} \frac{\tan^2\{x\}}{x^2 - [x]^2} & \text{for } x > 0 \\ 1 & \text{for } x = 0 \\ \sqrt{\{x\} \cot\{x\}} & \text{for } x < 0 \end{cases}$$

Then

A. LHL = 1

B. RHL = $\sqrt{\cot 1}$

$\lim_{x \rightarrow 0} f$ exist

C. (x)

D. $\lim_{x \rightarrow 0} f(x)$ does not exist

Ans. D

Solution:

$$\lim_{x \rightarrow 0^-} f(x) = \lim_{h \rightarrow 0} \sqrt{\{-h\} \cot\{-h\}}$$

$$= \lim_{h \rightarrow 0} \sqrt{(1-h) \cot(1-h)} = \sqrt{\cot 1}$$

$$\lim_{x \rightarrow 0^+} f(x) = \lim_{h \rightarrow 0} \frac{\tan^2\{h\}}{h^2 - |h|^2} = \lim_{h \rightarrow 0} \frac{\tan^2 h}{h^2} = 1$$

$\therefore \lim_{x \rightarrow 0} f(x)$ does not exist.

Let $f(x) = \sin x$, $g(x) = \cos x$, $h(x) = x^2$ then

42. $\lim_{x \rightarrow 1} \frac{f(g(h(x))) - f(g(h(1)))}{x-1} =$

A. 0

B. $-2 \sin 1 \cos(\cos 1)$

C. ∞

D. $-2 \sin 1 \cos 1$

Ans. B

Solution:

Given $f(x) = \sin x$, $g(x) = \cos x$, $h(x) = x^2$

$$\lim_{x \rightarrow 1} \frac{f(g(h(x))) - f(g(h(1)))}{x-1}$$

When limit is applied, it gives $\frac{0}{0}$ form, so we apply L'Hospital rule.

$$\Rightarrow \lim_{x \rightarrow 1} \frac{\cos(\cos x^2) (-\sin x^2)(2x) - 0}{1-0}$$

Apply the limit,

$$\Rightarrow -2(1) \sin(1) \cos(\cos 1)$$

$$= -2 \sin(1) \cos(\cos 1)$$

43. The Boolean expression $\sim (p \vee q) \vee (\sim p \wedge q)$ is equivalent to

A. p

B. q

C. $\sim q$

D. $\sim p$

Ans. D

Solution:

Given, $\sim (p \vee q) \vee (\sim p \wedge q)$
 $\Rightarrow (\sim p \wedge \sim q) \vee (\sim p \wedge q)$ (By De Morgan's Law)
 $\Rightarrow \sim p \wedge (\sim q \vee q)$ (Distributive Law)
 $\Rightarrow \sim p \wedge t$ (By complement law, where $t = \text{tautology}$)
 $\Rightarrow \sim p$ (Identity law)

44. If p : 2 is an even number

q : 2 is a prime number,

r : $2 + 2 = 2^2$

Then the symbolic statement $p \rightarrow (q \vee r)$ means

A. 2 is an even number and 2 is a prime number or $2 + 2 = 2^2$

B. 2 is an even number then 2 is a prime number or $2 + 2 = 2^2$.

C. 2 is an even number or 2 is a prime number then $2 + 2 = 2^2$

D. If 2 is not even number then 2 is a primenumber $\alpha = 2 + 2 = 2^2$

Ans. B

Solution:

$P \rightarrow (q \vee r)$. If 2 is even number then 2 is a prime number or $2 + 2 = 2^2$.

45. Consider the following statements :

A: Rishi is a judge.

B : Rishi is honest.

C: Rishi is not arrogant.

The negation of the statement "if Rishi is a judge and he is not arrogant, then he is honest" is

A. $B \rightarrow (A \vee C)$

B. $(\sim B) \wedge (A \wedge C)$

C. $B \rightarrow ((\sim A) \vee (\sim C))$

D. $B \rightarrow (A \wedge C)$

Ans. B

Solution:

$$\Rightarrow \frac{2(1 + \sin t) \cos t}{2 \cos^2 t} = \sqrt{3}$$
$$\Rightarrow t = \frac{\pi}{6}, y_0 = 27$$

46. If p : It raining today, q : I go to school, r : I shall meet any friends and s : I shall go for a movie, then which of the following is the proposition : 'If it does not rain or if I do not go to school, then I shall meet my friend and go for a movie'?

A. $\sim (p \wedge q) \Rightarrow (r \wedge s)$

B. $\sim (p \wedge \sim q) \Rightarrow (r \wedge s)$

C. $\sim (p \wedge q) \Rightarrow (r \vee s)$

D. None of these

Ans. A

Solution:

Correct result is $(\sim p \vee \sim q) \Rightarrow (r \wedge s)$

So, $\sim(p \wedge q) \Rightarrow (r \wedge s)$

47. Let p, q, r be three logical statements. Consider the compound statements

$S_1 : ((\sim p) \vee q) \vee ((\sim p) \vee r)$ and

$S_2 : p \rightarrow (q \vee r)$

Then, which of the following is NOT true?

A. If S_2 is true, then S_1 is true

B. If S_2 is false, then S_1 is false

C. If S_2 is false, then S_1 is true

D. If S_1 is false, then S_2 is false

Ans. C

Solution:

Given statement $S_1 : (\sim p \vee q) \vee (\sim p \vee r)$

$$\equiv \sim p \vee (q \vee r)$$

$$S_2 : p \rightarrow (q \vee r)$$

$$\equiv \sim p \vee (q \vee r) \rightarrow \text{By conditional law}$$

$$S_1 \equiv S_2$$

48. Consider the following two propositions:

$$P_1 : \sim (p \rightarrow \sim q)$$

$$P_2 : (p \wedge \sim q) \wedge ((\sim p) \vee q)$$

If the proposition $p \rightarrow ((\sim p) \vee q)$ is evaluated as FALSE, then :

- A. P_1 is TRUE and P_2 is FALSE
- B. P_1 is FALSE and P_2 is TRUE
- C. Both P_1 and P_2 are FALSE
- D. Both P_1 and P_2 are TRUE

Ans. C

Solution:

Given propositions $P_1 : \sim (p \rightarrow \sim q)$

$$P_2 : (p \wedge \sim q) \wedge ((\sim p) \vee q)$$

Required table is shown below.

p	q	$\sim p$	$\sim q$	$\sim p \vee q$	$p \rightarrow (\sim (p \vee q))$	$p \rightarrow \sim q$	$\sim (p \rightarrow \sim q)$	$p \wedge \sim q$	p_2
T	T	F	F	T	T	F	T	F	F
T	F	F	T	F	F	T	F	T	F
F	T	T	F	T	T	T	F	F	F
F	F	T	T	T	T	T	F	F	F

$p \rightarrow (\sim p \vee q)$ is *F* when p is true q is false From table P_1 & P_2 both are false

49. If the variance of the data 2, 3, 5, 8, 12 is σ^2 and the mean deviation from the median for this data is M , then $\sigma^2 - M =$

- A. 10.2
- B. 5.8
- C. 10.6

D. 8.2

Ans. A

Solution:

Observations : 2, 3, 5, 8, 12

$$\text{Mean} = \frac{2+3+5+8+12}{5} = 6$$

$$\therefore \sigma^2 = 13.2$$

$$\text{Median} = 5 = m$$

\therefore Mean deviation about median

$$\Rightarrow \frac{\sum |x_i - m|}{n} = \frac{3+2+0+3+7}{5} = 3$$

$$M = 3 \Rightarrow \sigma^2 - M = 13.2 - 3 = 10.2$$

50. The mean of n items is X . If the first item is increased by 1, second by 2 and so on, the new mean is :

A. $\bar{X} + \frac{x}{2}$

B. $\bar{X} + x$

C. $\bar{X} + \frac{n+1}{2}$

D. None of these

Ans. C

Solution:

Let the items be a_1, a_2, \dots, a_n

$$\text{then } \bar{X} = \frac{a_1 + a_2 + \dots + a_n}{n}$$

Now, according to the given condition:

$$\begin{aligned}\bar{X} &= \frac{(a_1+1) + (a_2+2) + \dots + (a_n+n)}{n} \\ &= \bar{X} + \frac{1+2+3+\dots+n}{n} = \bar{X} + \frac{n(n+1)}{2n}\end{aligned}$$

(using sum of n natural nos.)

$$= \bar{X} + \frac{n+1}{2}.$$

51. The variance of 20 observations is 5. If each observation is multiplied by 2, then the new variance of the resulting observation is

- A. $2^3 \times 5$
- B. $2^2 \times 5$
- C. 2×5
- D. $2^4 \times 5$

Ans. B

Solution:

Let the observations be x_1, x_2, \dots, x_{20} and \bar{x} be their mean. Given that, variance = 5 and $n = 20$. We know that,

$$\text{Variance } (\sigma^2) = \frac{1}{n} \sum_{i=1}^{20} (x_i - \bar{x})^2$$

$$\text{i.e. } 5 = \frac{1}{20} \sum_{i=1}^{20} (x_i - \bar{x})^2$$

$$\text{or } \sum_{i=1}^{20} (x_i - \bar{x})^2 = 100 \dots (i)$$

If each observation is multiplied by 2 and the new resulting observations are y_i , then

$$y_i = 2x_i \text{ i.e., } x_i = \frac{1}{2}y_i$$

Therefore,

$$\bar{y} = \frac{1}{n} \sum_{i=1}^{20} y_i = \frac{1}{20} \sum_{i=1}^{20} 2x_i = 2 \cdot \frac{1}{20} \sum_{i=1}^{20} x_i$$

$$\text{i.e., } \bar{y} = 2\bar{x} \text{ or } \bar{x} = \frac{1}{2}\bar{y}.$$

On substituting the values of x_i and \bar{x} in eq. (i), we get

$$\sum_{i=1}^{20} \left(\frac{1}{2}y_i - \frac{1}{2}\bar{y}\right)^2 = 100$$

$$\text{i.e., } \sum_{i=1}^{20} (y_i - \bar{y})^2 = 400$$

Thus, the variance of new observations

$$= \frac{1}{20} \times 400 = 20 = 2^2 \times 5.$$

52. If the function $f(x)$, defined below, is continuous on the interval $[0,8]$, then

$$f(x) = \begin{cases} x^2 + ax + b & , 0 \leq x < 2 \\ 3x + 2, & 2 \leq x \leq 4 \\ 2ax + 5b, & 4 < x \leq 8 \end{cases}$$

A. $a = 3, b = -2$

B. $a = -3, b = 2$

C. $a = -3, b = -2$

D. $a = 3, b = 2$

Ans. A

Solution:

Here, $f(x)$ is continuous on the interval $[0,8]$.

So it will also be continuous on 2 and 4.

At $x = 2$,

$$\lim_{x \rightarrow 2^-} f(x) = \lim_{x \rightarrow 2^+} f(x)$$

$$\lim_{x \rightarrow 2^-} (x^2 + ax + b) = \lim_{x \rightarrow 2^+} (3x + 2)$$

$$4 + 2a + b = 3(2) + 2$$

$$\therefore 2a + b = 4 \dots(i)$$

At $x = 4$

$$\lim_{x \rightarrow 4^-} f(x) = \lim_{x \rightarrow 4^+} f(x)$$

$$\lim_{x \rightarrow 4^-} (3x + 2) = \lim_{x \rightarrow 4^+} 2ax + 5b$$

$$3(4) + 2 = 2a(4) + 5b$$

$$\therefore 8a + 5b = 14 \dots(ii)$$

On solving Eqs. (i) and (ii), we get

$$a = 3 \text{ and } b = -2.$$

53. From the top of a cliff 50 m high, the angles of depression of the top and bottom of a tower are observed to be 30° and 45° . The height of tower is

- A. 50 m
- B. $50\sqrt{3}$ m
- C. $50(\sqrt{3} - 1)$ m
- D. $50\left(1 - \frac{\sqrt{3}}{3}\right)$ m

Ans. D

Solution:

According to condition,

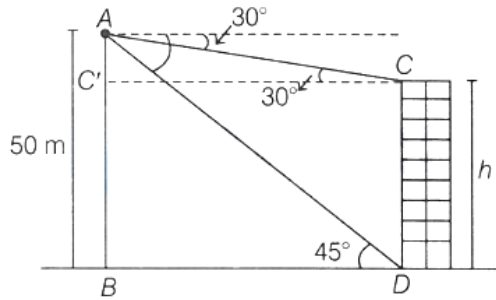

Let, height of tower = h

$$\text{In } \triangle ABD, \quad \tan 45^\circ = \frac{AB}{BD} \Rightarrow BD = 50 \text{ m}$$

Now, In $\triangle ACC'$

$$\begin{aligned} \tan 30^\circ &= \frac{AC'}{C'C} \\ \Rightarrow \frac{1}{\sqrt{3}} &= \frac{50 - h}{50} \\ \Rightarrow 50 &= 50\sqrt{3} - h\sqrt{3} \\ \Rightarrow h\sqrt{3} &= 50(\sqrt{3} - 1) \\ h &= 50 \left(1 - \frac{1}{\sqrt{3}} \right) \\ &= 50 \left(1 - \frac{\sqrt{3}}{3} \right) \text{ m} \end{aligned}$$

54. ABC is a triangular park with $AB = AC = 100$ m. A TV tower stands at the mid-point of BC. The angles of elevation of the top of the tower at A, B, C are $45^\circ, 60^\circ, 60^\circ$ respectively. The height of the tower is

- A. 50 m
- B. $50\sqrt{3}$ m
- C. $50\sqrt{2}$ m
- D. $50(3 - \sqrt{3})$ m

Ans. B

Solution:

According to question,

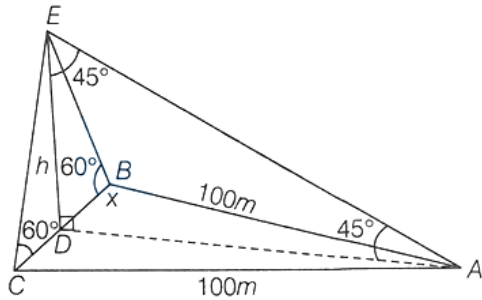

Let $DE = h$ and $CD = DB = x$

$$\text{In } \triangle EBD, \quad \tan 60^\circ = \frac{h}{x} \Rightarrow x = \frac{h}{\sqrt{3}}$$

Now, in $\triangle ADE$

$$\begin{aligned} \tan 45^\circ &= \frac{ED}{DA} \\ \Rightarrow DA &= h \end{aligned}$$

In $\triangle ABD$, by applying Pythagoras theorem

$$\begin{aligned} \Rightarrow \left(\frac{h}{\sqrt{3}}\right)^2 + h^2 &= 100^2 \\ \Rightarrow \frac{4h^2}{3} &= 10000 \quad \Rightarrow h = 50\sqrt{3} \end{aligned}$$

55. In a statistical investigation of 1003 families of Calcutta, it was found that 63 families has neither a radio nor a TV, 794 families has a radio and 187 has TV. The number of families in that group having both a radio and a TV is

- A. 36
- B. 41
- C. 32
- D. None of these

Ans. B

Solution:

$$\begin{aligned} \text{Given, } n(R) &= 794 \\ n(T) &= 187 \\ n(R \cup T)' &= 63 \\ n(\text{Total}) &= n(R \cup T) + n(R \cup T)' \\ \Rightarrow 1003 &= n(R \cup T) + 63 \\ \Rightarrow n(R \cup T) &= 940 \end{aligned}$$

By set theory

$$\begin{aligned} \Rightarrow n(R \cup T) &= n(R) + n(T) - n(R \cap T) \\ \Rightarrow 940 &= 794 + 187 - n(R \cap T) \\ \Rightarrow n(R \cap T) &= 981 - 940 = 41 \end{aligned}$$

56. Let R be the relation "is congruent to" on the set of all triangles in a plane is

- A. Reflexive only
- B. Symmetric only
- C. Symmetric and reflexive only
- D. Equivalence relation

Ans. D

Solution:

Let S denote the set of all triangles in a plane.

Let R be the relation on S defined by $(\Delta_1, \Delta_2) \in R$

\Rightarrow triangle $\Delta_1 \cong \Delta_2$:

(i) Let any triangle $\Delta \in S$, we have

$\Delta_1 \cong \Delta_2 \Rightarrow (\Delta, \Delta) \in R \forall \Delta \in S \Rightarrow R$ is reflexive on

(ii) Let $\Delta_1, \Delta_2 \in S$, such that $(\Delta_1, \Delta_2) \in R$, then $\Delta_1 \cong \Delta_2 \Rightarrow \Delta_2 \cong \Delta_1 \Rightarrow (\Delta_2, \Delta_1) \in R \Rightarrow R$ is symmetric

(iii) Again, let $\Delta_1, \Delta_2, \Delta_3 \in S$ such that $(\Delta_1, \Delta_2) \in R$ and

$(\Delta_2, \Delta_3) \in R \therefore \Delta_1 \cong \Delta_2 \cong \Delta_3$

$\therefore (\Delta_1, \Delta_3) \in R$

$\Rightarrow R$ is transitive.

$\therefore R$ is an equivalence relation.

57. Number of subsets of set of letter of word 'MONOTONE'.

A. 8

B. 256

C. 64

D. 32

Ans. D

Solution:

Set created out of alphabet of word 'MONO- TONE' is $\{M,N,O,T,E\}$

\therefore Total number of subsets = $2^5 = 32$

58. In an examination, 62% of the candidates failed in English, 42% in Mathematics and 20% in both. The number of those who passed in both the subjects is

A. 11

B. 16

C. 18

D. None of these

Ans. B

Solution:

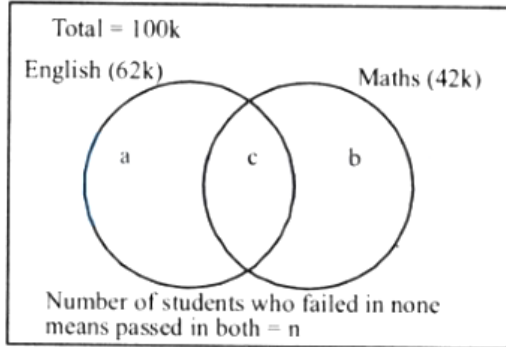

From the given condition,

$$a + c = 62k; b + c = 42k \text{ and } c = 20k$$

$$\text{Hence } a = 42k \text{ and } b = 22k$$

Number of students who failed in none means passed in both = $n = 100k - (a + b + c)$

$$= 100k - (42k + 22k + 20k) = 16k. \text{ or } 16\%$$

59. If $A = \frac{1}{3} \begin{bmatrix} 1 & 2 & 2 \\ 2 & 1 & -2 \\ a & 2 & b \end{bmatrix}$ is an orthogonal matrix, then

A. $a = -2, b = -1$

B. $a = 2, b = 1$

C. $a = 2, b = -1$

D. $a = -2, b = 1$

Ans. A

Solution:

We know that, if A is an orthogonal matrix, then

$$\Rightarrow AA^T = I$$

$$\Rightarrow \begin{bmatrix} 1 & 2 & 2 \\ 2 & 1 & -2 \\ a & 2 & b \end{bmatrix} \cdot \frac{1}{3} \begin{bmatrix} 1 & 2 & a \\ 2 & 1 & 2 \\ 2 & -2 & b \end{bmatrix} = \begin{bmatrix} 1 & 0 & 0 \\ 0 & 1 & 0 \\ 0 & 0 & 1 \end{bmatrix}$$

$$\Rightarrow \begin{bmatrix} 1 & 2 & 2 \\ 2 & 1 & -2 \\ a & 2 & b \end{bmatrix} \begin{bmatrix} 1 & 2 & a \\ 2 & 1 & 2 \\ 2 & -2 & b \end{bmatrix} = \begin{bmatrix} 9 & 0 & 0 \\ 0 & 9 & 0 \\ 0 & 0 & 9 \end{bmatrix}$$

$$\begin{bmatrix} 9 & 0 & a+4+2b \\ 0+4+2b & 9 & 2a+2-2b \\ 2a+2-2b & a^2+4+b^2 & \end{bmatrix}$$

$$= \begin{bmatrix} 9 & 0 & 0 \\ 0 & 9 & 0 \\ 0 & 0 & 9 \end{bmatrix}$$

$$\Rightarrow a+4+2b=0 \text{ and } 2a+2-2b=0$$

$$a+2b=-4 \dots (i)$$

$$a-b=-1 \dots (ii)$$

By solving Eqs. (i) and (ii), we get

$$a = -2, b = -1$$

60. If matrix $A = \begin{bmatrix} 3 & -2 & 4 \\ 1 & 2 & -1 \\ 0 & 1 & 1 \end{bmatrix}$ and $A^{-1} = \frac{1}{k} \text{adj}(A)$, then k is

- A. 7
- B. -7
- C. 15
- D. -11

Ans. C

Solution:

$$\text{Given, } A = \begin{bmatrix} 3 & -2 & 4 \\ 1 & 2 & -1 \\ 0 & 1 & 1 \end{bmatrix}$$

and

$$A^{-1} = \frac{1}{k} \text{adj}(A) \dots (i)$$

$$\text{We know that, } A^{-1} = \frac{\text{adj}(A)}{|A|} \dots (ii)$$

By comparing Eqs. (i) and (ii),

$$k = |A|$$

So,

$$\begin{aligned} |A| &= \begin{vmatrix} 3 & -2 & 4 \\ 1 & 2 & -1 \\ 0 & 1 & 1 \end{vmatrix} \\ &= 3(2 + 1) + 2(1 + 0) + 4(1 - 0) = 15 \end{aligned}$$

61. If A and B are symmetric matrices of same order such that $AB + BA = X$ and $AB - BA = Y$, then $(XY)^T =$

- A. XY
- B. $X^T Y^T$
- C. -YX
- D. $-Y^T X^T$

Ans. C

Solution:

$$\text{Since } XY = (AB + BA)(AB - BA)$$

$$= (AB)AB + (BA)(AB) - (AB)(BA) - (BA)(BA)$$

$$\text{Now } (XY)^T = ((AB) \cdot (AB))^T + (BA \cdot AB)^T - (AB \cdot BA)^T$$

$$= (AB)^T \cdot (AB)^T + (AB)^T \cdot (BA)^T - (BA)^T (AB)^T - (BA)^T (BA)^T$$

$$= (B^T \cdot A^T) (B^T \cdot A^T) + (B^T \cdot A^T) \cdot (A^T B^T)$$

$$- (A^T B^T) (B^T A^T) - (A^T B^T) (A^T B^T)$$

Since, A & B are symmetric matrix.

$$= (BA)(BA) + (BA)(AB) - (AB)(BA)$$

$$- (AB)(AB)$$

$$= (BA - AB)(BA + AB) = -YX$$

62. If $A = \begin{bmatrix} 1 & 0 \\ 0 & -1 \end{bmatrix}$, $P = \begin{bmatrix} 1 & 1 \\ 0 & 1 \end{bmatrix}$ and $X = APA^T$, then $A^T X^{50} A =$

A. $\begin{bmatrix} 0 & 1 \\ 1 & 0 \end{bmatrix}$

B. $\begin{bmatrix} 2 & 1 \\ 0 & -1 \end{bmatrix}$

C. $\begin{bmatrix} 25 & 1 \\ 1 & -25 \end{bmatrix}$

D. $\begin{bmatrix} 1 & 50 \\ 0 & 1 \end{bmatrix}$

Ans. D

Solution:

Since $AA^T = I$ therefore matrix A is orthogonal matrix.

$$\text{Now, } A^T X^{50} A = A^T X^{49} (APA^T) A$$

$$= A^T X^{49} AP (A^T A) = A^T X^{49} AP$$

$$= A^T X^{48} (APA^T) AP = A^T X^{48} AP^2 \dots\dots$$

$$= A^T AP^{50} = IP^{50} = P^{50}$$

$$\therefore P = \begin{bmatrix} 1 & 1 \\ 0 & 1 \end{bmatrix} \Rightarrow P^2 = \begin{bmatrix} 1 & 2 \\ 0 & 1 \end{bmatrix}$$

$$\Rightarrow P^3 = \begin{bmatrix} 1 & 3 \\ 0 & 1 \end{bmatrix} \dots\dots$$

$$\Rightarrow P^{50} = \begin{bmatrix} 1 & 50 \\ 0 & 1 \end{bmatrix}$$

$$\text{So, } A^T X^{50} A = P^{50} = \begin{bmatrix} 1 & 50 \\ 0 & 1 \end{bmatrix}$$

63. If A is a square matrix of order 3, then $|\text{Adj}(\text{Adj } A^2)| =$

A. $|A|^2$

B. $|A|^4$

C. $|A|^8$

D. $|A|^{16}$

Ans. C

Solution:

$$|\text{adj}(\text{adj } A^2)| =$$

$$|\text{adj } A| = |A|^{n-1} = |A|^2$$

$$|\text{adj } A^2| = |\text{adj } A|^2 = (|A|^2)^2 = |A|^4$$

$$|\text{adj}(\text{adj } A^2)| = (|A|^4)^{3-1}$$

$$= (|A|^4)^2 = |A|^8$$

64. Suppose $p, q, r \neq 0$ and system of equation

$$(p + a)x + by + cz = 0$$

$$ax + (q + b)y + cz = 0$$

$ax + by + (r + c)z = 0$, has a non-trivial solution, then the value of $\frac{a}{p} + \frac{b}{q} + \frac{c}{r}$ is

A. -1

B. 0

C. 1

D. 2

Ans. A

Solution:

$$\text{Let } |A| = \begin{vmatrix} p+a & b & c \\ a & q+b & c \\ a & b & r+c \end{vmatrix}$$

Also, given that equations has non trivial solution

$$|A| = 0$$

$$\begin{aligned} \Rightarrow \begin{vmatrix} p+a & b & c \\ a & q+b & c \\ a & b & r+c \end{vmatrix} &= 0 \\ \Rightarrow (p+a)[(q+b)(r+c) - bc] - b[a(r+c) - ca] &+ c[ab - a(q+b)] = 0 \\ \Rightarrow (p+a)[qr + qc + br] - b[ar] + c[-aq] &= 0 \\ \Rightarrow pqr + pqc + pbr + aqr &= 0 \end{aligned}$$

Dividing whole equation by pqr

$$\begin{aligned} \Rightarrow \frac{pqr}{pqr} + \frac{pqc}{pqr} + \frac{pbr}{pqr} + \frac{aqr}{pqr} &= 0 \\ \Rightarrow 1 + \frac{c}{r} + \frac{b}{q} + \frac{a}{p} &= 0 \\ \Rightarrow \frac{a}{p} + \frac{b}{q} + \frac{c}{r} &= -1 \end{aligned}$$

65. If x is a complex root of the equation

$$\begin{vmatrix} 1 & x & x \\ x & 1 & x \\ x & x & 1 \end{vmatrix} + \begin{vmatrix} 1-x & 1 & 1 \\ 1 & 1-x & 1 \\ 1 & 1 & 1-x \end{vmatrix} = 0,$$

then $x^{2007} + x^{-2007} =$

- A. 1
- B. -1
- C. -2
- D. 2

Ans. C

Solution:

Expanding the two determinants, we get

$$(1 - 3x^2 + 2x^3) + (3x^2 - x^3) = 0$$

$$\Rightarrow x^3 + 1 = 0$$

$$\Rightarrow x = -\omega, -\omega^2, -1$$

$$x^{2007} + x^{-2007} = -1 - 1 = -2$$

66. The equations $x - y + 2z = 4$

$$3x + y + 4z = 6$$

$$x + y + z = 1$$

have

- A. unique solution
- B. infinitely many solutions
- C. no solution
- D. two solutions

Ans. B

Solution:

Given equations, $x - y + 2z = 4$

$$3x + y + 4z = 6$$

$$x + y + z = 1$$

$$\text{Let } \Delta = \begin{vmatrix} 1 & -1 & 2 \\ 3 & 1 & 4 \\ 1 & 1 & 1 \end{vmatrix}$$

$$= 1(1 - 4) + 1(3 - 4) + 2(3 - 1)$$

$$= -3 - 1 + 4 = 0$$

$$\text{and } \Delta_1 = \begin{vmatrix} 4 & -1 & 2 \\ 6 & 1 & 4 \\ 1 & 1 & 1 \end{vmatrix}$$

$$= 4(1 - 4) + 1(6 - 4) + 2(6 - 1)$$

$$= -12 + 2 + 10 = 0$$

Now, $\Delta = 0$ and $\Delta_1 = 0$

\therefore These equations have infinitely many solutions.

67. If the system of linear equations $2x + y - z = 7$

$$x - 3y + 2z = 1; x + 4y + \delta z = k$$

where $\delta, k \in \mathbb{R}$ has infinitely many solutions, then $\delta + k$ is equal to:

A. -3

B. 3

C. 6

D. 9

Ans. B

Solution:

For getting infinite solutions $D = 0, D_1 = D_2 = D = 0$ then check all the three equations

$$\text{Let } \Delta = \begin{vmatrix} 2 & 1 & -1 \\ 1 & -3 & 2 \\ 1 & 4 & \delta \end{vmatrix} = 0 \Rightarrow \delta = -3$$

$$\text{And } \Delta_1 = \begin{vmatrix} 7 & 1 & -1 \\ 1 & -3 & 2 \\ k & 4 & -3 \end{vmatrix} = 0 \Rightarrow k = 6$$

$$\Rightarrow \delta + k = 3$$

$$\text{If } \cot(\cos^{-1} x) = \sec\left\{\tan^{-1}\left(\frac{a}{\sqrt{b^2-a^2}}\right)\right\}$$

68. $b > a$, then $x =$

A. $\frac{b}{\sqrt{2b^2-a^2}}$

B. $\frac{\sqrt{b^2-a^2}}{ab}$

C. $\frac{a}{\sqrt{2b^2-a^2}}$

D. $\frac{\sqrt{b^2-a^2}}{a}$

Ans. A

Solution:

Given that,

$$\cot(\cos^{-1} x) = \sec\left\{\tan^{-1}\left(\frac{a}{\sqrt{b^2-a^2}}\right)\right\}$$

$$\text{Since, } \cos^{-1} x = \cot^{-1}\left(\frac{x}{\sqrt{1-x^2}}\right) \text{ and } \tan^{-1} x = \sec^{-1}(\sqrt{1+x^2})$$

$$\Rightarrow \cot\left(\cot^{-1}\frac{x}{\sqrt{1-x^2}}\right) =$$

$$\sec\left\{\sec^{-1}\sqrt{1+\left(\frac{a}{\sqrt{b^2-a^2}}\right)^2}\right\}$$

$$\Rightarrow \frac{x}{\sqrt{1-x^2}} = \sqrt{\frac{b^2-a^2+a^2}{b^2-a^2}}$$

$$\Rightarrow \frac{x}{\sqrt{1-x^2}} = \frac{b}{\sqrt{b^2-a^2}}$$

On squaring both the sides, we get

$$\Rightarrow \frac{x^2}{1-x^2} = \frac{b^2}{b^2-a^2}$$

$$\Rightarrow x^2 b^2 - x^2 a^2 = b^2 - b^2 x^2$$

$$x^2 b^2 + b^2 x^2 - x^2 a^2 = b^2$$

$$\Rightarrow 2x^2 b^2 - x^2 a^2 = b^2 \Rightarrow x^2 (2b^2 - a^2) = b^2$$

$$\Rightarrow x = \frac{b}{\sqrt{2b^2 - a^2}}$$

69. If $\cos \cot^{-1}(1/2) = \cot(\cos^{-1} x)$, then the value of x is

- A. $1/\sqrt{6}$
- B. $-1/\sqrt{12}$
- C. $2/\sqrt{6}$
- D. $-2/\sqrt{6}$

Ans. A

Solution:

We have

$$\cos(\cot^{-1}(\frac{1}{2})) = \cot(\cos^{-1} x)$$

$$\text{Let } \cot^{-1}(\frac{1}{2}) = \alpha \Rightarrow \cot \alpha = \frac{1}{2} \Rightarrow \cos^{-1} \frac{1}{\sqrt{5}}$$

$$\Rightarrow \cos(\cos^{-1} \frac{1}{\sqrt{5}}) = \cot(\cot^{-1} \frac{x}{\sqrt{1-x^2}})$$

$$\Rightarrow \frac{1}{\sqrt{5}} = \frac{x}{\sqrt{1-x^2}} \Rightarrow \sqrt{1-x^2} = \sqrt{5}x$$

On squaring both sides, we get,

$$1 - x^2 = 5x^2 \Rightarrow 1 = 6x^2$$

$$\Rightarrow x = \pm \frac{1}{\sqrt{6}}$$

$$x = \frac{1}{\sqrt{6}} \quad [\text{neglecting - ve sign}]$$

70. Let $[x]$ denote the greatest integer $\leq x$. If $f(x) = [x]$ and $g(x) = |x|$, then the value of $f(g(\frac{8}{5})) - g(f(-\frac{8}{5}))$ is

A. 2

B. -2

C. 1

D. -1

Ans. D

Solution:

Given, $f(x) = [x]$ and $g(x) = |x|$

Now,

$$f\left(\frac{-8}{5}\right) = \left[\frac{-8}{5}\right] = -2 \dots (i)$$

$$g\left(\frac{8}{5}\right) = \left|\frac{8}{5}\right| = \frac{8}{5} \dots (ii)$$

$$\text{Now, } f\left(g\left(\frac{8}{5}\right)\right) - g\left(f\left(\frac{-8}{5}\right)\right) = f\left(\frac{8}{5}\right) - g(-2)$$

By Eqs. (i) and (ii),

$$\begin{aligned} &= \left[\frac{8}{5}\right] - |-2| \\ &= 1 - 2 \\ &= -1 \end{aligned}$$

71. Number of real solution of $\sqrt{5 - \log_2 |x|} = 3 - \log_2 |x|$ is equal to

- A. 1
- B. 2
- C. 3
- D. 4

Ans. B

Solution:

$$\begin{aligned} \text{Let } \log_2 |x| &= t \dots (i) \\ \therefore \sqrt{5-t} &= 3-t \\ \Rightarrow 5-t &= (3-t)^2 \\ \Rightarrow 5-t &= 9+t^2-6t \\ \Rightarrow t^2-5t+4 &= 0 \\ \Rightarrow (t-4)(t-1) &= 0 \\ \Rightarrow t &= 1 \text{ or } 4 [\text{rejected}] \\ [\because \sqrt{5-4} &= 3-4, 1 \neq -1] \\ \Rightarrow \log_2 |x| &= 1 \\ \Rightarrow |x| &= 2 \\ \Rightarrow x &= \pm 2 \end{aligned}$$

\therefore Total 2 real solutions.

72. $f(x) = \frac{\cos x}{\left[\frac{2x}{\pi}\right] + \frac{1}{2}}$, where x is not an integral multiple of π and $[\cdot]$ denotes the greatest integer function, is

- A. an odd function
- B. an even function
- C. neither odd nor even
- D. None of these

Ans. A

Solution:

$$f(-x) = \frac{\cos(-x)}{\left[-\frac{2x}{\pi}\right] + \frac{1}{2}} = \frac{\cos x}{-1 - \left[\frac{2x}{\pi}\right] + \frac{1}{2}}$$

(As x is not an integral multiple of π)

$$= -\frac{\cos x}{\left[\frac{2x}{\pi}\right] + \frac{1}{2}} = -f(x)$$

Therefore, $f(x)$ is an odd function.

73. The function $f: \mathbf{R} \rightarrow \mathbf{R}$ defined by $f(x) = \frac{x}{\sqrt{1+x^2}}$ is

- A. surjective but not injective
- B. bijective
- C. injective but not surjective
- D. neither injective nor surjective

Ans. C

Solution:

Given that, $f(x) = \frac{x}{\sqrt{1+x^2}}$

For injective: Let $x_1, x_2 \in \mathbf{R}$ such that $f(x_1) = f(x_2)$

$$\Rightarrow \frac{x_1}{\sqrt{1+x_1^2}} = \frac{x_2}{\sqrt{1+x_2^2}} \Rightarrow \frac{x_1^2}{1+x_1^2} = \frac{x_2^2}{1+x_2^2}$$

$$\Rightarrow x_1^2 + x_1^2 x_2^2 = x_2^2 + x_1^2 x_2^2 \Rightarrow x_1^2 = x_2^2$$

$$\Rightarrow x_1 = x_2$$

So, $f(x)$ is injective.

For surjective: Let $y = \frac{x}{\sqrt{1+x^2}}$

$$\Rightarrow y^2(1+x^2) = x^2 \Rightarrow y^2 + y^2 x^2 = x^2$$

$$\Rightarrow x^2(1-y^2) = y^2 \Rightarrow x = \sqrt{\frac{y^2}{1-y^2}}$$

$$\Rightarrow \frac{y^2}{1-y^2} \geq 0$$

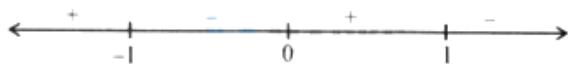

$$\therefore y \in (-1, 1)$$

So, $f(x)$ is not surjective.

74. If $f: \mathbf{R} \rightarrow \mathbf{R}$, $g: \mathbf{R} \rightarrow \mathbf{R}$ are defined by $f(x) = 5x - 3$, $g(x) = x^2 + 3$, then $g \circ f^{-1}(3)$ is equal to

A. 25/3

B. 111/25

C. 9/25

D. 25/111

Ans. B

Solution:

Given, $f(x) = 5x - 3$ and $g(x) = x^2 + 3$

Let, $y = f(x)$, $\therefore y = 5x - 3$

$$y + 3 = 5x \Rightarrow x = \frac{y+3}{5}$$

$$\therefore f^{-1}(y) = \frac{y+3}{5} \Rightarrow f^{-1}(x) = \frac{x+3}{5}$$

Now, $g(x) = x^2 + 3$

So, $g \circ f^{-1}(3) = g[f^{-1}(3)]$

$$= g\left(\frac{3+3}{5}\right) = g\left(\frac{6}{5}\right) = \left(\frac{6}{5}\right)^2 + 3 = \frac{36}{25} + 3 = \frac{111}{25}$$

75. The domain of the real valued function

$$f(x) = \sqrt{\frac{2x^2 - 7x + 5}{3x^2 - 5x - 2}}$$
 is

A. $(-\infty, -\frac{1}{3}) \cup [1, 2) \cup [\frac{5}{2}, \infty)$

B. $(-\infty, 1) \cup (2, \infty)$

C. $(-\frac{1}{3}, \frac{5}{2}]$

D. $(-\infty, -\frac{1}{3}] \cup [\frac{5}{2}, \infty)$

Ans. A

Solution:

Given function $f(x) = \sqrt{\frac{2x^2 - 7x + 5}{3x^2 - 5x - 2}}$

Here, $f(x)$ should be greater than or equal to 0 .

So, $2x^2 - 7x + 5 = 0$

$\Rightarrow 2x^2 - 5x - 2x + 5 = 0$

$\Rightarrow (x - 1)(2x - 5) = 0$

$\Rightarrow x = 1, \frac{5}{2}$

$3x^2 - 5x - 2 = 0 \Rightarrow 3x^2 - 6x + x - 2 = 0$

$3x(x - 2) + 1(x - 2) = 0 \Rightarrow (x - 2)(3x + 1) = 0$

$\Rightarrow x = 2, -\frac{1}{3}$

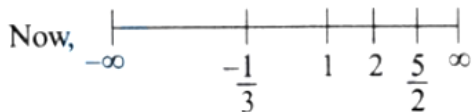

When we include $x = -1/3, 2$ then $f(x)$ would give not define value so, we will exclude these values from the domain.

When we take values between $(-\frac{1}{3}, 1)$ and

So, domain is $(-\infty, -\frac{1}{3}) \cup [1, 2) \cup [\frac{5}{2}, \infty)$

76. If a function $f : \mathbb{R} - \{1\} \rightarrow \mathbb{R} - \{m\}$ defined by $f(x) = x + 3/x - 2$ is a bijection, then $3l + 2m =$

- A. 10
- B. 12
- C. 8
- D. 14

Ans. C

Solution:

$$f(x) = \frac{x+3}{x-2}$$

$\therefore f(x)$ is not defined for $x = 2$

i.e. domain of $f(x)$ is $\mathbb{R} - \{2\}$

$$\therefore l = 2$$

$$\text{Now, } y = \frac{x+3}{x-2}$$

$$xy - 2y = x + 3$$

$$x(y - 1) = 2y + 3$$

$$x = \frac{2y+3}{y-1}$$

y can take any value except $y = 1$

$$\text{Co-domain} = \mathbb{R} - \{1\}$$

$$m = 1$$

$$3l + 2m = 3(2) + 2(1) = 8$$

77. $f(x) = \sin x + \cos x, g(x) = x^2 - 1$, then $g(f(x))$ is invertible if

A. $-\frac{\pi}{4} \leq x \leq \frac{\pi}{4}$

B. $-\frac{\pi}{2} \leq x \leq 0$

C. $-\frac{\pi}{2} \leq x \leq \pi$

D. $0 \leq x \leq \frac{\pi}{2}$

Ans. A

Solution:

Given that, $f(x) = \sin x + \cos x$

$$g(x) = x^2 - 1$$

$$g[f(x)] = (\sin x + \cos x)^2 - 1$$

$$= \sin^2 x + \cos^2 x + 2 \sin x \cos x - 1$$

$$= 1 + \sin 2x - 1 = \sin 2x$$

$$(\because \sin^2 x + \cos^2 x = 1, \sin x = 2 \sin x \cos x)$$

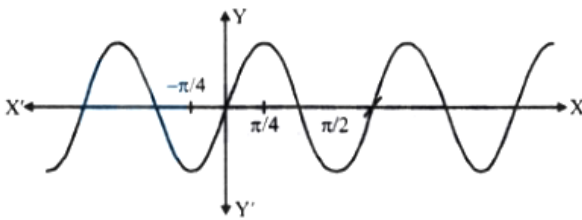

Among the given options, $\sin 2x$ is monotonous

(here strictly increasing) in $-\frac{\pi}{4} \leq x \leq \frac{\pi}{4}$.

So, $g(f(x))$ is invertible in $-\frac{\pi}{4} \leq x \leq \frac{\pi}{4}$.

78. Let the function $g : (-\infty, \infty) \rightarrow (-\pi/2, \pi/2)$ be given by $g(u) = 2 \tan^{-1}(e^u) - \pi/2$. Then, g is

- A. even and is strictly increasing in $(0, \infty)$
- B. odd and is strictly decreasing in $(-\infty, \infty)$
- C. odd and is strictly increasing in $(-\infty, \infty)$
- D. neither even nor odd, but is strictly increasing in $(-\infty, \infty)$

Ans. C

Solution:

Given that $g(u) = 2 \tan^{-1}(e^u) - \frac{\pi}{2}$

$$\therefore g(-u) = 2 \tan^{-1}(e^{-u}) - \frac{\pi}{2} =$$

$$2 \tan^{-1}\left(\frac{1}{e^u}\right) - \frac{\pi}{2}$$

$$= 2 \cot^{-1}(e^u) - \frac{\pi}{2} = 2 \left[\frac{\pi}{2} - \tan^{-1}(e^u) \right] - \frac{\pi}{2}$$

$$= \pi - 2 \tan^{-1}(e^u) - \frac{\pi}{2}$$

$$= \frac{\pi}{2} - 2 \tan^{-1}(e^u) = -g(u)$$

$\therefore g$ is an odd function.

$$\text{Also } g'(u) = \frac{2e^u}{1+e^{2u}} > 0, \forall u \in (-\infty, \infty)$$

$\therefore g$ is strictly increasing on $(-\infty, \infty)$.

79. Let f be the function defined by

$$f(x) = \begin{cases} \frac{x^2-1}{x^2-2|x-1|-1}, & x \neq 1 \\ \frac{1}{2}, & x = 1 \end{cases}$$

A. The function is continuous for all values of x

B. The function is continuous only for $x > 1$

C. The function is continuous at $x = 1$

D. The function is not continuous at $x = 1$

Ans. D

Solution:

$$f(x) = \begin{cases} \frac{x^2-1}{x^2-2x+1}; & x > 1 \\ \frac{1}{2}; & x = 1 \\ \frac{x^2-1}{x^2+2x-3}; & x < 1 \end{cases}$$

$$\therefore x^2 + 3x - x - 3$$

$$= x(x+3) - 1(x+3)$$

Lets Find

$$\text{LHL, } \lim_{x \rightarrow 1^-} \frac{x^2-1}{x^2-2x+1} \text{ and RHL, } \lim_{x \rightarrow 1^+} \frac{x^2-1}{x^2+2x-3}$$

$$\Rightarrow \lim_{x \rightarrow 1^-} \frac{(x-1)(x+1)}{(x-1)^2} \Rightarrow \lim_{x \rightarrow 1^+} \frac{(x-1)(x+1)}{(x+3)(x-1)}$$

$$\Rightarrow \lim_{x \rightarrow 1^-} \frac{x+1}{x-1} = \infty \Rightarrow \lim_{x \rightarrow 1^+} \frac{x+1}{x+3} = \frac{2}{4} = \frac{1}{2}$$

$\therefore \text{LHL} \neq f(1) \Rightarrow f(x)$ is not continuous at $x = 1$

80. If $f(x) = \begin{cases} \frac{x^2 \log(\cos x)}{\log(1+x)}, & x \neq 0 \\ 0, & x = 0 \end{cases}$, then at $x = 0$, $f(x)$ is

- A. not continuous
- B. continuous but not differentiable
- C. differentiable
- D. not continuous, but differentiable

Ans. C

Solution:

$$\lim_{x \rightarrow 0} f(x) = \lim_{x \rightarrow 0} \frac{x^2 \log(\cos x)}{\log(1+x)}$$

$$= \lim_{x \rightarrow 0} \frac{x \cdot \log(\cos x)}{\frac{\log(1+x)}{x}}$$

$$= \lim_{x \rightarrow 0} x \cdot \log(\cos x) = 0 \cdot \log 1 = 0$$

$$\therefore \lim_{x \rightarrow 0} f(x) = f(0)$$

$\therefore f(x)$ is continuous at $x = 0$

$$\text{Now, } \lim_{x \rightarrow 0} \frac{f(x+h) - f(x)}{h}$$

$$\lim_{h \rightarrow 0} \frac{f(h) - f(0)}{h} = \lim_{h \rightarrow 0} \frac{h^2 \log \cos h - 0}{\log(1+h)}$$

$$\lim_{h \rightarrow 0} \frac{h^2 \log(\cos h)}{1} = 0$$

$\therefore f(x)$ is differentiable at $x = 0$

81.
$$f(x) = \begin{cases} 4 & -\infty < x < -\sqrt{5} \\ x^2 - 1 & -\sqrt{5} \leq x \leq \sqrt{5} \\ 4 & \sqrt{5} \leq x < \infty \end{cases}$$

If k is the number of points where $f(x)$ is not differentiable then $k - 2 =$

A. 2

B. 1

C. 0

D. 3

Ans. C

Solution:

Here $f(x)$ is continuous $\forall x \in \mathbf{R}$

Now At $x = -\sqrt{5}$

$$\text{L.H.D} = 0$$

$$\text{R.H.D} = 2x = -2\sqrt{5}$$

$\Rightarrow f(x)$ is not differentiable at $x = -\sqrt{5}$

At $x = \sqrt{5}$

$$\text{L.H.D.} = 2x = 2\sqrt{5}$$

$$\text{R.H.D.} = 0$$

$\Rightarrow f(x)$ is not differentiable at $x = \sqrt{5}$

$$\Rightarrow k = 2$$

$$k - 2 = 2 - 2 = 0$$

82. If $x\sqrt{1+y} + y\sqrt{1+x} = 0$, then $\frac{dy}{dx} =$

A. $x+1/x$

B. $1/1+x$

C. $-1/(1+x)^2$

D. $x/1+x$

Ans. C

Solution:

$$\text{Given, } x\sqrt{1+y} + y\sqrt{1+x} = 0$$

$$\Rightarrow x\sqrt{1+y} = -y\sqrt{1+x}$$

$$\Rightarrow (x\sqrt{1+y})^2 = (-y\sqrt{1+x})^2$$

$$\Rightarrow x^2(1+y) = y^2(1+x)$$

$$\Rightarrow x^2 - y^2 = y^2x - x^2y$$

$$\Rightarrow (x-y)(x+y) = xy(y-x)$$

$$\Rightarrow x+y = -xy$$

$$\Rightarrow x+y+xy = 0$$

$$\Rightarrow y = \frac{-x}{1+x} = -1 + \frac{1}{1+x}$$

Differentiating w.r.t, x

$$\frac{dy}{dx} = -\frac{1}{(1+x)^2}$$

If $y = \tan^{-1}\left(\frac{\sqrt{x-x}}{1+x^{\frac{3}{2}}}\right)$, then $y'(1)$ is equal to
83.

A. 0

B. $1/2$

C. -1

D. $-1/4$

Ans. D

Solution:

$$y = \tan^{-1}\left(\frac{\sqrt{x-x}}{1+x^{\frac{3}{2}}}\right)$$

$$\text{Given, } y = \tan^{-1}\left(\frac{\sqrt{x-x}}{1+\sqrt{x}\cdot x}\right)$$

$$y = \tan^{-1}(\sqrt{x}) - \tan^{-1}x$$

$$\left[\because \tan^{-1}\left(\frac{x-y}{1+xy}\right) = \tan^{-1}x - \tan^{-1}y\right]$$

Differentiating w.r.t x

$$y'(x) = \frac{dy}{dx} = \frac{1}{1+x} \times \frac{1}{2\sqrt{x}} - \frac{1}{1+x^2}$$

$$\text{Now, } y'(1) = \frac{1}{2} \times \frac{1}{2} - \frac{1}{2} = -\frac{1}{4}$$

84. $\text{At } x = \frac{\pi^2}{4}, \frac{d}{dx} (\tan^{-1}(\cos \sqrt{x}) + \sec^{-1}(e^x)) =$

A. $\frac{1}{\sqrt{e^{\frac{\pi^2}{2}} - 1}} - \frac{1}{\pi}$

B. $\frac{\pi}{4} + \frac{1}{\sqrt{e^{\pi^2} + e^{\pi^2/2}}}$

C. $\frac{1}{\sqrt{e^{\pi^2} + e^{\pi^2/2}}} + \frac{2}{\pi} \cot\left(\frac{\sqrt{\pi}}{2}\right)$

D. $\frac{1}{\sqrt{e^{\pi}}} + \frac{1}{\pi}$

Ans. A

Solution:

$$\begin{aligned} & \frac{d}{dx} (\tan^{-1}(\cos \sqrt{x}) + \sec^{-1}(e^x)) \\ &= \frac{(-\sin \sqrt{x})}{1 + \cos^2 \sqrt{x}} \cdot \left(\frac{1}{2\sqrt{x}}\right) + \frac{1}{e^x \sqrt{e^{2x} - 1}} \cdot e^x \\ & \text{but when } x = \frac{\pi^2}{4} \\ &= -\frac{\sin \frac{\pi}{2}}{1 + \cos^2 \frac{\pi}{2}} \left(\frac{1}{2}\right) \left(\frac{2}{\pi}\right) + \frac{1}{\sqrt{e^{\pi^2/2} - 1}} \\ &= -\frac{1}{\pi} + \frac{1}{\sqrt{e^{\pi^2/2} - 1}} \end{aligned}$$

85. The maximum area of rectangle inscribed in a circle of diameter R is

A. R^2

B. $R^2/2$

C. $R^2/4$

D. $R^2/8$

Ans. B

Solution:

According to question,

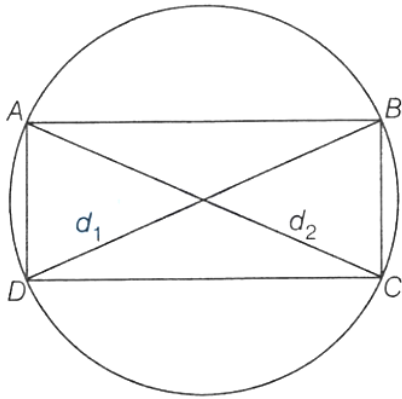

Diameter = R

Diagonals, $d_1 = d_2 = R$

$$\begin{aligned} \text{Max Area of rectangle (any quadrilateral)} &= \frac{1}{2}d_1 \times d_2 \\ &= \frac{1}{2} \times R \times R = \frac{R^2}{2} \end{aligned}$$

86. Consider the function $f(x) = \frac{|x-1|}{x^2}$, then $f(x)$ is

- A. increasing in $(0,1) \cup (2, \infty)$
- B. increasing in $(-\infty, 0) \cup (0, 1)$
- C. decreasing in $(-\infty, 0) \cup (2, \infty)$
- D. decreasing in $(0,1) \cup (2, \infty)$

Ans. D

Solution:

$$\text{Given, } f(x) = \begin{cases} \frac{x-1}{x^2}; x \geq 1 \\ -\frac{x+1}{x^2}; x < 1 \end{cases}$$

$$f(x) = \begin{cases} \frac{1}{x} - \frac{1}{x^2}; & x \geq 1 \\ -\frac{1}{x} + \frac{1}{x^2}; & x < 1 \end{cases}$$

$$f'(x) = \begin{cases} -\frac{1}{x^2} + \frac{2}{x^3}; & x \geq 1 \\ \frac{1}{x^2} - \frac{2}{x^3}; & x < 1 \end{cases}$$

$$f'(x) = \begin{cases} \frac{2-x}{x^3}; & x \geq 1 \\ \frac{x-2}{x^3}; & x < 1 \end{cases}$$

By observation, $f'(x)$ will be



Decreasing in $(0,1) \cup (2,\infty)$

and increasing in $(-\infty, 0) \cup (1,2)$

87. The maximum volume (in cu. units) of the cylinder which can be inscribed in a sphere of radius 12 units is

- A. $384\sqrt{3}\pi$
- B. $768\sqrt{3}\pi$
- C. $768\pi/\sqrt{3}$
- D. $1152\pi/\sqrt{3}$

Ans. B

Solution:

$$12^2 = r^2 + \left(\frac{h}{2}\right)^2 \Rightarrow V = \pi r^2 h$$

$$\Rightarrow V = \pi \left(144 - \frac{h^2}{4}\right) h$$

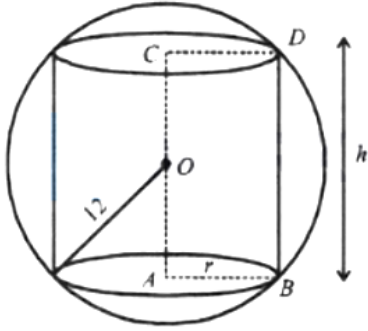

$$\Rightarrow V = 144\pi h - \frac{\pi}{4}h^3 \Rightarrow \frac{dV}{dh} = 144\pi - \frac{3\pi}{4}h^2$$

$$\Rightarrow \frac{dV}{dh} = 0 \Rightarrow 144\pi = \frac{3\pi}{4}h^2$$

$$\Rightarrow h^2 = 48 \times 4 \Rightarrow h = 8\sqrt{3}$$

$$\therefore 12^2 = r^2 + 48 \Rightarrow r^2 = 96$$

$$\text{Volume} = \pi r^2 h = \pi \times 96 \times 8\sqrt{3} = 768\sqrt{3}\pi \text{ cm}^3.$$

88. If the angle made by the tangent at the point (x_0, y_0) on the curve $x = 12(t + \sin t)$, $y = 12(1 + \sin t)^2$, $0 < t < \pi/2$, with the positive x-axis is $\pi/3$, then y_0 is equal to

(1 + $\sin t$)², $0 < t < \pi/2$, with the positive x-axis is $\pi/3$, then y_0 is equal to

A. $6(3 + 2\sqrt{2})$

B. $3(7 + 4\sqrt{3})$

C. 27

D. 48

Ans. C

Solution:

Given equation of curve

$$x = 12(t + \sin t \cos t), y = 12(1 + \sin t)^2$$

Differentiate w.r.t 't',

$$\frac{dx}{dt} = 12(1 + \cos^2 t - \sin^2 t)$$

$$\frac{dx}{dt} = 12(1 + \cos 2t) \text{ and } \frac{dy}{dt} \\ = 24(1 + \sin t) \cos t$$

$$\frac{dy}{dx} = \frac{2(1 + \sin t) \times \cos t}{1 + \cos 2t}$$

89. The altitude of a cone is 20 cm and its semi-vertical angle is 30° . If the semi-vertical angle is increasing at the rate of 2° per second, then the radius of the base is increasing at the rate of

- A. 30 cm/sec
- B. $160/3$ cm/sec
- C. 10 cm/sec
- D. 160 cm/sec

Ans. B

Solution:

Let θ be the semi-vertical angle and r be the radius of the cone at time t .

the radius of the cone at time t .

Then, $r = 20 \tan \theta$

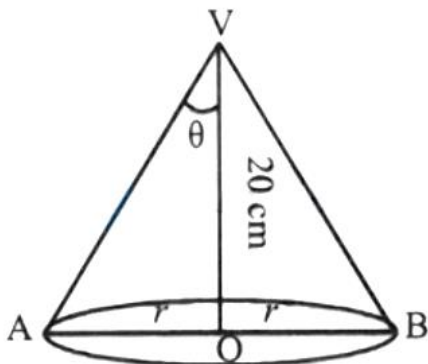

$$\Rightarrow \frac{dr}{dt} = 20 \sec^2 \theta \frac{d\theta}{dt}$$

$$\Rightarrow \frac{dr}{dt} = 20 \sec^2 30^\circ \times 2$$

$$[\because \theta = 30^\circ \text{ and } \frac{d\theta}{dt} = 2]$$

$$\Rightarrow \frac{dr}{dt} = 20 \times \frac{4}{3} \times 2 \text{ cm/s} = \frac{160}{3} \text{ cm/s}$$

90. The point of inflexion for the curve $y = (x - a)^n$, where n is odd integer and $n \geq 3$ is

- A. $(a, 0)$
- B. $(0, a)$
- C. $(0, 0)$
- D. None of these

Ans. A

Solution:

$$\text{Here } \frac{d^2y}{dx^2} = n(n-1)(x-a)^{n-2}$$

$$\text{Now, } \frac{d^2y}{dx^2} = 0 \Rightarrow x = a$$

Differentiating equation of the curve n times,

$$\text{we get, } \frac{d^ny}{dx^n} = n!$$

$$\therefore \text{ at } x = a, \frac{d^ny}{dx^n} \neq 0 \text{ and } \frac{d^{n-1}y}{dx^{n-1}} = 0,$$

where n is odd.

Therefore $(a, 0)$ is the point of inflexion

91. The population $p(t)$ at time t of a certain mouse species satisfies the differential equation $\frac{dp(t)}{dt} = 0.5p(t) - 450$. If $p(0) = 850$, then the time at which the population becomes zero is :

- A. $2 \ln 18$
- B. $\ln 9$

C. $\frac{1}{2} \ln 18$

D. $\ln 18$

Ans. A

Solution:

Given differential equation is

$$\frac{dp(t)}{dt} = 0.5p(t) - 450$$

$$\Rightarrow \frac{dp(t)}{dt} = \frac{1}{2}p(t) - 450$$

$$\Rightarrow \frac{dp(t)}{dt} = \frac{p(t) - 900}{2}$$

$$\Rightarrow 2 \frac{dp(t)}{dt} = -[900 - p(t)]$$

$$\Rightarrow 2 \frac{dp(t)}{900 - p(t)} = -dt$$

Integrate both the side, we get :

$$-2 \int \frac{dp(t)}{900 - p(t)} = \int dt$$

$$\text{Let } 900 - p(t) = u \Rightarrow -dp(t) = du$$

$$\therefore \text{ We have; } 2 \int \frac{du}{u} = \int dt \Rightarrow 2 \ln u = t + c$$

$$\Rightarrow 2 \ln[900 - p(t)] = t + c \text{ when } t = 0, p(0) = 850$$

$$2 \ln(50) = c \Rightarrow 2 \left[\ln \left(\frac{900 - p(t)}{50} \right) \right] = t$$

$$\Rightarrow 900 - p(t) = 50e^{\frac{t}{2}}$$

$$\Rightarrow p(t) = 900 - 50e^{\frac{t}{2}}$$

$$\text{let } p(t_1) = 0$$

$$0 = 900 - 50e^{\frac{t_1}{2}} \quad \therefore t_1 = 2 \ln 18$$

92. $\int \frac{x^3 - 1}{x^3 + x} dx =$

A. $x + \log|x| + \frac{1}{2} \log(x^2 + 1) + \sin^{-1}(x) + c$

B. $x - \log|x| + 1/2\log(x^2 + 1) - \sin^{-1}(x) + c$

C. $x + \log|x| - 1/2\log(x^2 + 1) + \tan^{-1}(x) + c$

D. $x - \log|x| + 1/2\log(x^2 + 1) - \tan^{-1}(x) + c$

Ans. D

Solution:

$$I = \int \left(\frac{x^3-1}{x^3+x} \right) dx = \int \left(1 - \frac{x+1}{x^3+x} \right) dx$$

$$\Rightarrow I = \int 1 \cdot dx - \int \frac{(x+1)}{x^3+x} dx$$

$$= x - \int \frac{(x+1)}{x(x^2+1)} dx$$

$$\text{Let } \frac{x+1}{x(x^2+1)} = \frac{A}{x} + \frac{Bx+C}{x^2+1}$$

$$\Rightarrow (x+1) = A(x^2+1) + (Bx+C)x$$

$$\Rightarrow (x+1) = (A+B)x^2 + Cx + A$$

On comparing coefficient, we get

$$A + B = 0, C = 1, A = 1$$

$$\Rightarrow B = -1$$

$$\therefore I = x - \int \frac{1}{x} dx - \int \frac{(1-x)}{x^2+1} dx$$

$$\Rightarrow I = x - \log|x| - \int \frac{1}{x^2+1} dx + \frac{1}{2} \int \frac{2x}{x^2+1} dx$$

$$\Rightarrow I = x - \log|x| - \tan^{-1} x + \frac{1}{2} \log(x^2+1) + c$$

93. $\int \sqrt{x + \sqrt{x^2 + 2}} dx =$

A. $\frac{3}{2}(x + \sqrt{x^2 + 2})^{3/2} - 2(x + \sqrt{x^2 + 2})^{1/4} + C$

B. $\frac{1}{3}(x + \sqrt{x^2 + 2})^{3/2} - 2(x + \sqrt{x^2 + 2})^{1/4} + C$

C. $(x + \sqrt{x^2 + 2})^{-3/2} - 2(x + \sqrt{x^2 + 2})^{-1/2} + C$

$$D. \frac{(x+\sqrt{x^2+2})^2-6}{3\sqrt{x+\sqrt{x^2+2}}} + C$$

Ans. D

Solution:

$$\int \sqrt{x + \sqrt{x^2 + 2}} dx$$

$$\sqrt{x + \sqrt{x^2 + 2}} = t \Rightarrow x + \sqrt{x^2 + 2} = t^2$$

$$\sqrt{x^2 + 2} = t^2 - x$$

$$\Rightarrow x^2 + 2 = t^4 + x^2 - 2t^2x$$

$$\Rightarrow x = \frac{t^4 - 2}{2t^2} \Rightarrow dx = \frac{t^4 + 2}{t^3} dt$$

$$\int t \cdot \frac{t^4 + 2}{t^3} dt = \int \left(t^2 + \frac{2}{t^2} \right) dt = \frac{t^3}{3} - \frac{2}{t} + C$$

$$= \frac{t^3}{3} - \frac{2}{t} + C = \frac{t^4 - 6}{3t} + C$$

$$= \frac{(x + \sqrt{x^2 + 2})^2 - 6}{3\sqrt{x + \sqrt{x^2 + 2}}} + C$$

94. The value of $\int e^{\tan\theta} (\sec\theta - \sin\theta) d\theta$ is

- A. $e^{\tan\theta} \sec\theta + c$
- B. $e^{\tan\theta} \sin\theta + c$
- C. $e^{\tan\theta} (\sec\theta + \sin\theta) + c$
- D. $e^{\tan\theta} \cos\theta + c$

Ans. D

Solution:

$$\text{Let } I = \int e^{\tan \theta} (\sec \theta - \sin \theta) d\theta$$

$$\text{Put } \tan \theta = t \Rightarrow \sec^2 \theta d\theta = dt \Rightarrow d\theta = \frac{dt}{1+t^2}$$

$$\Rightarrow I = \int e^t \left(\sqrt{1+t^2} - \frac{t}{\sqrt{1+t^2}} \right) \frac{dt}{1+t^2}$$

$$= \int e^t \left(\frac{1}{\sqrt{1+t^2}} - \frac{t}{(1+t^2)^{3/2}} \right) dt$$

Integrating first part by parts we have,

$$= \frac{1}{\sqrt{1+t^2}} e^t + \int \frac{t}{(1+t^2)^{3/2}} \cdot e^t dt$$

$$- \int \frac{t}{(1+t^2)^{3/2}} e^t dt + c$$

$$= \frac{e^t}{\sqrt{1+t^2}} + c = e^{\tan \theta} \cos \theta + c$$

95. $\int_0^\infty \frac{dx}{(x^2+a^2)(x^2+b^2)}$ is

A. $\frac{\pi ab}{a+b}$

B. $\frac{ab}{2(a+b)}$

C. $\frac{\pi}{2ab(a+b)}$

D. $\frac{\pi(a+b)}{2ab}$

Ans. C

Solution:

$$I = \int_0^\infty \frac{1}{(x^2+a^2)(x^2+b^2)} dx$$

$$I = \frac{1}{a^2-b^2} \int_0^\infty \frac{(x^2+a^2) - (x^2+b^2)}{(x^2+a^2)(x^2+b^2)} dx$$

$$I = \frac{1}{a^2-b^2} \int_0^\infty \left[\frac{1}{(x^2+b^2)} - \frac{1}{(x^2+a^2)} \right] dx$$

$$\text{Let } I = \frac{1}{a^2-b^2} \left[\frac{1}{b} \tan^{-1} \frac{x}{b} - \frac{1}{a} \tan^{-1} \frac{x}{a} \right]_0^\infty$$

$$I = \frac{1}{a^2-b^2} \left[\frac{1}{b} \times \frac{\pi}{2} - \frac{1}{a} \times \frac{\pi}{2} \right]$$

$$I = \frac{1}{(a+b)(a-b)} \left[\frac{a-b}{ab} \right] \times \frac{\pi}{2}$$

$$I = \frac{\pi}{2ab(a+b)}$$

96. The value of definite integral $\int_0^{\pi/2} \log(\tan x) dx$ is

A. 0

B. $\pi/4$

C. $\pi/2$

D. π

Ans. A

Solution:

$$\text{Let } I = \int_0^{\pi/2} \log(\tan x) dx \dots (i)$$

By applying property,

$$\int_a^b f(x) dx = \int_a^b f(a+b-x) dx$$
$$I = \int_0^{\pi/2} \log\left(\tan\left(\frac{\pi}{2} - x\right)\right) dx$$
$$I = \int_0^{\pi/2} \log(\cot x) dx \dots (ii)$$

Adding Eqs. (i) and (ii),

$$2I = \int_0^{\pi/2} [\log(\tan x) + \log(\cot x)] dx$$
$$2I = \int_0^{\pi/2} \log 1 dx = 0$$

97. $\int_5^9 \frac{\log 3x^2}{\log 3x^2 + \log(588 - 84x + 3x^2)} dx$ is equal to

A. 2

B. 1

C. 1/2

D. 4

Ans. A

Solution:

Let

$$\begin{aligned} I &= \int_5^9 \frac{\log 3x^2 dx}{\log 3x^2 + \log(588 - 84x + 3x^2)} \dots(i) \\ &= \int_5^9 \frac{\log 3x^2 dx}{\log 3x^2 + \log 3(14 - x)^2} \\ &= \int_5^9 \frac{\log 3(14 - x)^2 dx}{\log 3(14 - x)^2 + \log 3(14 - (14 - x))^2} \\ &\quad \left[\int_a^b f(x) dx = \int_a^b f(a + b - x) dx \right] \end{aligned}$$

$$I = \int_5^9 \frac{\log 3(14 - x)^2 dx}{\log 3(14 - x)^2 + \log 3x^2} \dots(ii)$$

Adding Eqs. (i) and (ii), we get

$$\begin{aligned} 2I &= \int_5^9 \frac{\log 3x^2 + \log 3(14 - x)^2}{\log 3(14 - x)^2 + \log 3x^2} dx \\ 2I &= \int_5^9 dx = 9 - 5 = 4 \Rightarrow I = 2 \end{aligned}$$

98. The integral $\int \frac{x^2(x \sec^2 x + \tan x)}{(x \tan x + 1)^2} dx$ is equal to

A. $-\frac{x^2}{x \tan x + 1} + c$

B. $2 \log_e |x \sin x + \cos x| + c$

C. $-\frac{x^2}{x \tan x + 1} + 2 \log_e |x \sin x + \cos x| + c$

D. $\frac{x^2}{x^2 \tan x - 1} - 2 \log_e |x \sin x + \cos x| + c$

Ans. C

Solution:

(c) We note that

$$\frac{d}{dx}(x \tan x + 1) = x \sec^2 x + \tan x$$

∴ integrating by parts with x^2 as first function, we get

$$\begin{aligned} I &= \int x^2 \frac{x \sec^2 x + \tan x}{(x \tan x + 1)^2} dx \\ &= x^2 \left(-\frac{1}{x \tan x + 1} \right) - \int 2x \left(-\frac{1}{x \tan x + 1} \right) dx \\ &= -\frac{x^2}{x \tan x + 1} + 2 \int \frac{x \cos x}{x \sin x + \cos x} dx \\ &= -\frac{x^2}{x \tan x + 1} + 2 \log_e |x \sin x + \cos x| + c \\ &\quad \left(\because \frac{d}{dx}(x \sin x + \cos x) = x \cos x \right) \end{aligned}$$

99. $\lim_{n \rightarrow \infty} \prod_{r=3}^{\infty} \frac{r^3 - 8}{r^3 + 8}$ equals to

A. 2/7

B. 3/7

C. 4/7

D. 6/7

Ans. A

Solution:

$$\begin{aligned} \lim_{n \rightarrow \infty} \prod_{r=3}^{\infty} \frac{r^3 - 8}{r^3 + 8} &= \left(\frac{3^3 - 8}{3^3 + 8} \right) \left(\frac{4^3 - 8}{4^3 + 8} \right) \\ &\dots \dots \dots \left(\frac{n^3 - 8}{n^3 + 8} \right) \\ &= \lim_{n \rightarrow \infty} \left[\frac{(3-2)(3^2+2^2+3.2)}{(3+2)(3^2+2^2-3.2)} \right] \left[\frac{(4-2)(4^2+2+4.2)}{(4+2)(4^2+2^2-4.2)} \right] \\ &\dots \dots \dots \left[\frac{(n-2)(n^2+2^n+n.2)}{(n+2)(n^2+2^2-n.2)} \right] \\ &= \lim_{n \rightarrow \infty} \left[\frac{(3-2)(4-2) \dots \dots \dots (n-2)}{(3+2)(4+2) \dots \dots \dots (n+2)} \right] \\ &\left[\frac{(3^2+2^2+3.2)(4^2+2^2+4.2) \dots \dots \dots (n^2+2^2+n.2)}{(3^2+2^2-3.2)(4^2+2^2-4.2) \dots \dots \dots (n^2+2^2-n.2)} \right] \\ &= \left[\frac{1 \cdot 2 \cdot 3 \cdot 4 \cdot 5 \cdot 6 \cdot \dots \dots \dots}{5 \cdot 6 \cdot 7 \cdot 8 \cdot \dots \dots \dots} \right] \left[\frac{19 \cdot 28 \cdot 39 \cdot 52 \cdot 63 \cdot \dots \dots \dots}{7 \cdot 12 \cdot 19 \cdot 28 \cdot 39 \cdot 52 \cdot \dots \dots \dots} \right] \\ &= \frac{2}{7} \end{aligned}$$

$$100. \int_0^{\frac{\pi}{2}} \frac{\sin\left(\frac{\pi}{4}+x\right)+\sin\left(\frac{3\pi}{4}+x\right)}{\cos x+\sin x} dx =$$

- A. $\pi/\sqrt{2}$
- B. $\pi/2\sqrt{2}$
- C. $\pi/3\sqrt{2}$
- D. $\pi/4\sqrt{2}$

Ans. B

Solution:

$$\begin{aligned} \text{Let } I &= \int_0^{\frac{\pi}{2}} \frac{\sin\left(\frac{\pi}{4}+x\right)+\sin\left(\frac{3\pi}{4}+x\right)}{\cos x+\sin x} dx \\ \Rightarrow I &= \int_0^{\pi/2} \frac{\sin\left(\frac{3\pi}{4}-x\right)+\sin\left(\frac{5\pi}{4}-x\right)}{\sin x+\cos x} dx \\ \Rightarrow I &= \int_0^{\pi/2} \frac{\sin\left(\frac{\pi}{4}+x\right)-\sin\left(\frac{3\pi}{4}+x\right)}{\cos x+\sin x} dx \\ \text{Now } I + I &= \int_0^{\pi/2} \frac{2\sin\left(\frac{\pi}{4}+x\right)}{\cos x+\sin x} dx \\ \Rightarrow I &= \int_0^{\pi/2} \frac{\frac{1}{\sqrt{2}}\cos x + \frac{1}{\sqrt{2}}\sin x}{\cos x - \sin x} dx = \frac{\pi}{2\sqrt{2}} \end{aligned}$$

101. The line $y = mx$ bisects the area enclosed by lines $x = 0$, $y = 0$ and $x = 3/2$ and the curve $y = 1 + 4x - x^2$. Then, the value of m is

- A. $13/6$
- B. $13/2$
- C. $13/5$
- D. $13/7$

Ans. A

Solution:

Given, $y = 1 + 4x - x^2$

$$\Rightarrow \frac{dy}{dx} = 4 - 2x = 0 \Rightarrow x = 2 \text{ [point of maxima]}$$

$$\Rightarrow y_{\max} = 1 + 4 \times 2 - 4 = 5$$

when, $x = 0, y = 1$

∴ Graph according to question and above information

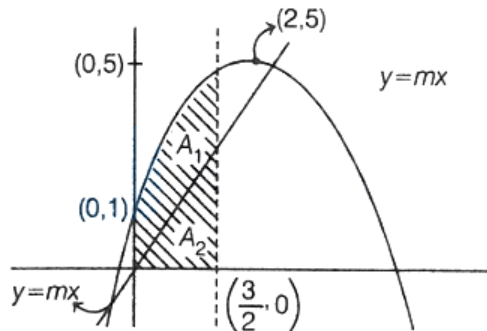

⇒ If $y = mx$ bisects the area bounded

$$\Rightarrow A_1 = A_2$$

$$\Rightarrow \int_0^{3/2} (1 + 4x - x^2) dx = 2 \int_0^{3/2} mx dx$$

$$\Rightarrow \left[x + 2x^2 - \frac{x^3}{3} \right]_0^{3/2} = [mx^2]_0^{3/2}$$

$$\Rightarrow \frac{3}{2} + 2 \times \frac{9}{4} - \frac{27}{8} \times \frac{1}{3} = m \times \frac{9}{4}$$

$$\therefore m = \frac{13}{6}$$

102. If a, c, b are in GP, then the area of the triangle formed by the lines $ax + by + c = 0$ with the coordinates axes is equal to

- A. 1
- B. 2
- C. $1/2$
- D. None of these

Ans. C

Solution:

Given a, c, b are in GP

$$\Rightarrow c^2 = ab \dots (i)$$

According to question,

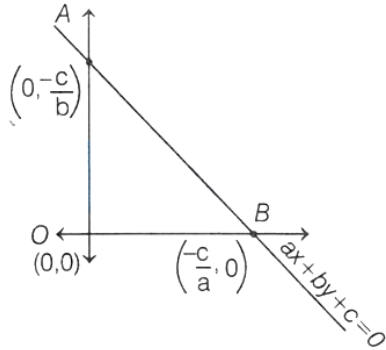

$$\begin{aligned} \therefore \text{Area of } \triangle OAB &= \left| \frac{1}{2} \times OA \times OB \right| \\ &= \left| \frac{1}{2} \times \left(\frac{-c}{b} \right) \times \left(\frac{-c}{a} \right) \right| \\ &= \frac{1}{2} \times \frac{c^2}{ab} = \frac{1}{2} [\text{by Eq. (i)}] \end{aligned}$$

103. The area enclosed by the curves $y = x^3$ and $y = \sqrt{x}$ is

- A. $5/3$ sq. units
- B. $5/4$ sq. units
- C. $5/12$ sq. unit
- D. $12/5$ sq. units

Ans. C

Solution:

Given curves are $y = x^3$ and $y = \sqrt{x}$

Both curves intersect at $x = 0$ and $x = 1$

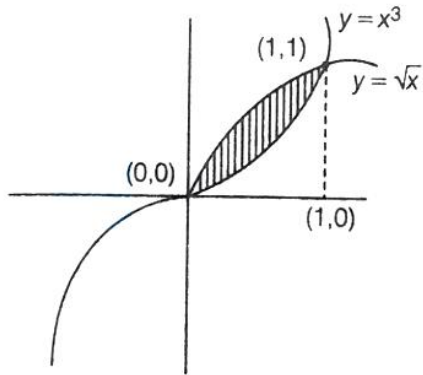

Shaded region is required area

$$\begin{aligned}
 A &= \left| \int_0^1 (x^3 - \sqrt{x}) dx \right| = \left| \left[\frac{x^4}{4} - \frac{2x^{3/2}}{3} \right]_0^1 \right| \\
 &= \left| \left[\frac{1}{4} - \frac{2}{3} \right] \right| \\
 &= \frac{5}{12} \text{ sq. unit}
 \end{aligned}$$

104. The area of the region bounded by the curves $x = y^2 - 2$ and $x = y$ is

- A. $9/4$
- B. 9
- C. $9/2$
- D. $9/7$

Ans. C

Solution:

Given, $x = y^2 - 2$ and $x = y$.

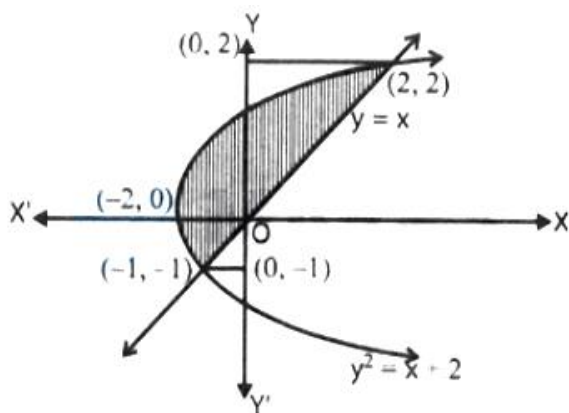

On solving, $x = y^2 - 2$ and $x = y$, we get $(-1, -1)$ and $(2, 2)$.

Area of the shaded region,

$$\begin{aligned} A &= \int_{-1}^2 y dy - \int_{-1}^2 (y^2 - 2) dy \\ &= \left[\frac{y^2}{2} - \frac{y^3}{3} + 2y \right]_{-1}^2 = \left(\frac{4}{2} - \frac{8}{3} + 4 \right) - \left(\frac{1}{2} + \frac{1}{3} - 2 \right) \\ &= \frac{10}{3} + \frac{7}{6} = \frac{27}{6} = \frac{9}{2}. \end{aligned}$$

105. If the area bounded by the curves $y = ax^2$ and $x = ay^2$, ($a > 0$) is 3 sq units, then the value of a is

- A. $2/3$
- B. $1/3$
- C. 1
- D. 4

Ans. B

Solution:

We have given, $y = ax^2$ (i)

and $x = ay^2$ (ii)

Put the value of y by Eq. (i) in Eq. (ii), we get

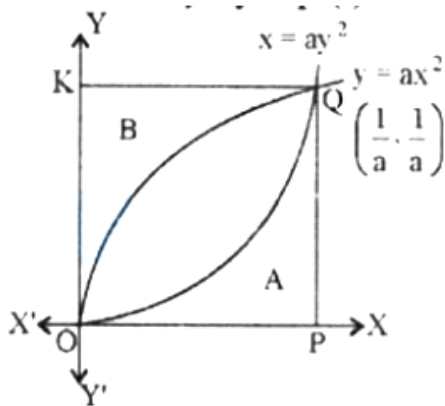

$$x = a \times a^2 x^4 \Rightarrow x^4 a^3 - x = 0$$

$$x(x^3 a^3 - 1) = 0 \Rightarrow x = 0, \frac{1}{a}$$

$$\text{When, } x = 0 \Rightarrow y = 0 \text{ and } x = \frac{1}{a} \Rightarrow y = \frac{1}{a}$$

Here, points of intersection of curves $y = ax^2$

and $x = ay^2$ are $(0, 0)$ and $(\frac{1}{a}, \frac{1}{a})$.

∴ Required area

$$A = \int_{x=a}^{x=b} [f_2(x) - f_1(x)] dx$$

$$3 = \int_0^{1/a} \left(\frac{\sqrt{x}}{\sqrt{a}} - ax^2 \right) dx$$

$$3 = \left[\frac{1}{\sqrt{a}} \times \frac{2}{3} x^{3/2} - \frac{ax^3}{3} \right]_0^{1/a}$$

$$3 = \frac{2}{3\sqrt{a}} \left[\left(\frac{1}{a} \right)^{3/2} \right] - \frac{a}{3} \left[\left(\frac{1}{a} \right)^3 \right]$$

$$3 = \frac{2}{3\sqrt{a}} \times \frac{1}{a\sqrt{a}} - \frac{a}{3} \times \frac{1}{a^3}$$

$$3 = \frac{2}{3a^2} - \frac{1}{3a^2} \Rightarrow 3 = \frac{2-1}{3a^2} \Rightarrow 9a^2 = 1$$

$$a^2 = \frac{1}{9} \Rightarrow a = \frac{1}{3}$$

106. The solution of the differential equation $(x + 1)dy/dx - y = e^{3x}(x + 1)^2$ is

A. $y = (x + 1)e^{3x} + C$

B. $3y = (x + 1) + e^{3x} + C$

C. $\frac{3y}{x+1} = e^{3x} + C$

D. $ye^{-3x} = 3(x + 1) + C$

Ans. C

Solution:

Given, $\frac{dy}{dx} - \frac{y}{x+1} = e^{3x}(x+1)$

Above is linear differential equation of form

$$\frac{dy}{dx} + Px = Q$$

$$\therefore \text{IF} = e^{\int P dx} = e^{\int -\frac{1}{x+1} dx} = e^{-\ln(1+x)} = \frac{1}{1+x}$$

⇒ Solution will be

$$y \cdot \text{IF} = \int Q \cdot \text{IF} dx$$

$$y \cdot \frac{1}{1+x} = \int e^{3x}(x+1) \times \frac{1}{(1+x)} dx$$

$$\frac{y}{1+x} = \frac{e^{3x}}{3} + C'$$

$$\frac{3y}{1+x} = e^{3x} + C' \quad [\because C = 3C']$$

107. If $\frac{dy}{dx} - y \log_e 2 = 2^{\sin x} (\cos x - 1) \log_e 2$, then y

- A. $2^{\sin x} + c2^x$
- B. $2^{\cos x} + c2^x$
- C. $2^{\sin x} + c2^{-x}$
- D. $2^{\cos x} + c2^{-x}$

Ans. A

Solution:

$$\frac{dy}{dx} - y \log_e 2 = 2^{\sin x} (\cos x - 1) \log_e 2$$

This is linear differential equation

$$\text{I.F.} = e^{-\log_e 2 \int dx} = e^{-x \log_e 2} = 2^{-x}$$

then general Solution is

$$y2^{-x} = \int 2^{-x} 2^{\sin x} (\cos x - 1) \log_e 2 dx + c$$

Now let $\sin x - x = t \Rightarrow (\cos x - 1) dx = dt$

$$\therefore y2^{-x} = \log_e 2 \int 2^t dt + c$$

$$\therefore y2^{-x} = 2^t + c$$

$$\therefore y = 2^{x+t} + c2^x$$

$$\therefore y = 2^{\sin x} + c2^x$$

108. Let $\mathbf{a} = \hat{i} - \hat{k}$, $\mathbf{b} = x\hat{i} + \hat{j} + (1-x)\hat{k}$ and $\mathbf{c} = y\hat{i} + x\hat{j} + (1+x-y)\hat{k}$. Then, $[\mathbf{a} \mathbf{b} \mathbf{c}]$ depends on

- A. only y
- B. only x
- C. both x and y
- D. neither x nor y

Ans. D

Solution:

Here, $[\mathbf{a} \mathbf{b} \mathbf{c}] = |\mathbf{a} \cdot (\mathbf{b} \times \mathbf{c})|$

Now, according to question,

$$\begin{aligned}
 [\mathbf{a} \ \mathbf{b} \mathbf{c}] &= \begin{vmatrix} 1 & 0 & -1 \\ x & 1 & 1-x \\ y & x & 1+x-y \end{vmatrix} \\
 &= 1(1+x-y-x(1-x)) - 1(x^2-y) \\
 &= 1+x-y-x+x^2-x^2+y \\
 &= 1 \\
 &= \text{Independent of } x \text{ and } y.
 \end{aligned}$$

109. Let ABC be a triangle and be $\vec{a}, \vec{b}, \vec{c}$ the position vectors of A,B,C respectively. Let D divide BC in the ratio 3 : 1 internally and E divide AD in the ratio 4 : 1 internally. Let BE meet AC in F. If E divides BF in the ratio 3 : 2 internally then the position vector of F is

- A. $\frac{\vec{a} + \vec{b} + \vec{c}}{3}$
- B. $\frac{\vec{a} - 2\vec{b} + 3\vec{c}}{2}$
- C. $\frac{\vec{a} + 2\vec{b} + 3\vec{c}}{2}$
- D. $\frac{\vec{a} - \vec{b} + 3\vec{c}}{3}$

Ans. D

Solution:

Here we are given that

$$\vec{OA} = \vec{a}, \vec{OB} = \vec{b}, \vec{OC} = \vec{c}$$

$$\text{Now P.V of Di.e } \vec{OD} = \frac{1 \times \vec{OB} + 3 \times \vec{OC}}{1+3}$$

$$\vec{OD} = \frac{\vec{b} + 3\vec{c}}{4}$$

$$\vec{OE} = \frac{4\vec{OD} + \vec{OA}}{4+1} = \frac{4(\frac{\vec{b}+3\vec{c}}{4}) + \vec{a}}{5}$$

$$\Rightarrow \vec{OE} = \frac{\vec{a} + \vec{b} + 3\vec{c}}{5}$$

$$\text{Now, } \vec{OF} = \frac{2\vec{OB} + 3\vec{OE}}{2+3}$$

$$\Rightarrow \vec{OF} = \frac{5\vec{OE} - 2\vec{OB}}{3}$$

$$\Rightarrow \vec{OF} = \frac{\frac{5(\vec{a} + \vec{b} + 3\vec{c})}{5} - 2\vec{b}}{3}$$

$$\Rightarrow \vec{OF} = \frac{\vec{a} - \vec{b} + 3\vec{c}}{3} \Rightarrow \text{P.V. of F is } \frac{\vec{a} - \vec{b} + 3\vec{c}}{3}$$

110. If $\vec{a} = 2\hat{i} + \hat{j} + 2\hat{k}$, then the value of

$$|\hat{i} \times (\vec{a} \times \hat{i})|^2 + |\hat{j} \times (\vec{a} \times \hat{j})|^2 + |\hat{k} \times (\vec{a} \times \hat{k})|^2$$

is equal to

- A. 17
- B. 18
- C. 19
- D. 20

Ans. B

Solution:

$$\hat{i} \times (\vec{a} \times \hat{i}) = (\hat{i} \cdot \hat{i})\vec{a} - (\hat{i} \cdot \vec{a})\hat{i} = \hat{j} + 2\hat{k}$$

$$\text{Similarly, } \hat{j} \times (\vec{a} \times \hat{j}) = 2\hat{i} + 2\hat{k}$$

$$\hat{k} \times (\vec{a} \times \hat{k}) = 2\hat{i} + \hat{j}$$

$$\begin{aligned} \Rightarrow & |\hat{j} + 2\hat{k}|^2 + |2\hat{i} + 2\hat{k}|^2 + |2\hat{i} + \hat{j}|^2 \\ & = 5 + 8 + 5 = 18 \end{aligned}$$

111. The magnitude of projection of line joining (3,4, 5) and (4,6,3) on the line joining (-1,2,4) and (1,0,5) is

- A. $\frac{4}{3}$
- B. $\frac{2}{3}$
- C. $\frac{8}{3}$
- D. $\frac{1}{3}$

Ans. A

Solution:

We know that, projection of \mathbf{a} on \mathbf{b} is given by projection, $|\mathbf{a}| \cos \theta = \frac{(\mathbf{a} \cdot \mathbf{b})}{|\mathbf{b}|}$

Let line joining points (3, 4, 5) and (4, 6, 3) is L_1 and line joining points (-1, 2, 4) and (1, 0, 5) is L_2

$$\Rightarrow \begin{aligned} L_1 &= \hat{\mathbf{i}} + 2\hat{\mathbf{j}} - 2\hat{\mathbf{k}} \\ L_2 &= 2\hat{\mathbf{i}} - 2\hat{\mathbf{j}} + \hat{\mathbf{k}} \end{aligned}$$

$$\therefore \text{Projection of } L_1 \text{ and } L_2 = \frac{L_1 \cdot L_2}{|L_2|}$$

$$= \frac{2 - 4 - 2}{\sqrt{4 + 4 + 1}} = \frac{-4}{3}$$

$$\therefore \text{Magnitude} = \frac{4}{3}$$

112. The angle between the lines whose direction cosines are given by the equations $3l + m + 5n = 0$, $6nm - 2n/l + 5/m = 0$ is

- A. $\cos^{-1}\left(\frac{1}{6}\right)$
- B. $\cos^{-1}\left(-\frac{1}{6}\right)$
- C. $\cos^{-1}\left(\frac{2}{3}\right)$
- D. $\cos^{-1}\left(-\frac{5}{6}\right)$

Ans. B

Solution:

The given equations are

$$3l + m + 5n = 0 \dots(i)$$

$$\text{and } 6mn - 2nl + 5lm = 0 \dots(ii)$$

From (i), we have $m = -3l - 5n$.

Putting $m = -3l - 5n$ in (ii),

$$\text{we get } 6(-3l - 5n)n - 2nl + 5l(-3l - 5n) = 0$$

$$\Rightarrow (n + l)(2n + l) = 0$$

$$\Rightarrow \text{either } l = -n \text{ or } l = -2n.$$

If $l = -n$, then putting $l = -n$ in (i), we obtain $m = -2n$.

If $l = -2n$, then putting $l = -2n$ in (i), we obtain $m = n$.

Thus, the direction ratios of two lines are $-n, -2n, n$ and $-2n, n, n$ i.e., $1, 2, -1$ and $-2, 1, 1$.

Hence, the direction cosines are

$$\frac{1}{\sqrt{6}}, \frac{2}{\sqrt{6}}, \frac{-1}{\sqrt{6}} \text{ or } \frac{-2}{\sqrt{6}}, \frac{1}{\sqrt{6}}, \frac{1}{\sqrt{6}}. \text{ The angle } \theta$$

between the lines is given by

$$\cos \theta = \frac{1}{\sqrt{6}} \times \frac{-2}{\sqrt{6}} + \frac{2}{\sqrt{6}} \times \frac{1}{\sqrt{6}} + \frac{-1}{\sqrt{6}} \times \frac{1}{\sqrt{6}} = \frac{-1}{6}$$
$$\Rightarrow \theta = \cos^{-1}\left(\frac{-1}{6}\right)$$

113. Let the acute angle bisector of the two planes $x - 2y - 2z + 1 = 0$ and $2x - 3y - 6z + 1 = 0$ be the plane P. Then which of the following points lies on P?

A. $(3, 1, -1/2)$

B. $(-2, 0, -1/2)$

C. $(0, 2, -4)$

D. $(4, 0, -2)$

Ans. B

Solution:

Given that $P_1 : x - 2y - 2z + 1 = 0$

$P_2 : 2x - 3y - 6z + 1 = 0$

Equation of plane bisectors

$$\left| \frac{x - 2y - 2z + 1}{\sqrt{1 + 4 + 4}} \right| = \left| \frac{2x - 3y - 6z + 1}{\sqrt{2^2 + 3^2 + 6^2}} \right|$$
$$\frac{x - 2y - 2z + 1}{3} = \pm \frac{2x - 3y - 6z + 1}{7}$$

Since $a_1a_2 + b_1b_2 + c_1c_2 = 20 > 0$

\therefore Negative sign will be taken for acute bisector.

$$\Rightarrow 7x - 14y - 14z + 7 = -[6x - 9y - 18z + 3]$$

$$\Rightarrow 13x - 23y - 32z + 10 = 0$$

$\left(-2, 0, -\frac{1}{2}\right)$ satisfy it

114. Let the foot of perpendicular from a point $P(1, 2, -1)$ to the straight line $L : \frac{x}{1} = \frac{y}{0} = \frac{z}{-1}$ be N . Let a line be drawn from P parallel to the plane $x + y + 2z = 0$ which meets L at point Q . If α is the acute angle between the lines PN and PQ , then $\cos \alpha$ is equal to

- A. $1/\sqrt{5}$
- B. $\sqrt{3}/2$
- C. $1/\sqrt{3}$
- D. $1/2\sqrt{3}$

Ans. C

Solution:

$$\text{Let } \frac{x}{1} = \frac{y}{0} = \frac{z}{-1} = \lambda$$

$$\Rightarrow N(\lambda, 0, -\lambda)$$

$$\vec{b} = \hat{i} - \hat{k}$$

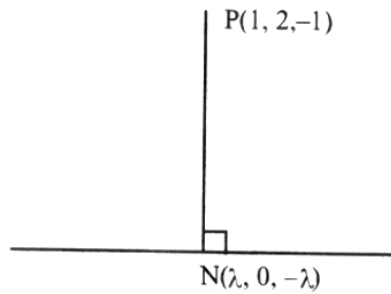

$$\therefore \vec{PN} \cdot \vec{b} = 0$$

$$\Rightarrow 1(1 - \lambda) - (\lambda - 1) = 0 \Rightarrow \lambda = 1$$

$$\Rightarrow N(1, 0, -1)$$

Let $Q(\mu, 0, -\mu)$

$$\therefore \vec{n} = \hat{i} + \hat{j} + 2\hat{k}$$

Now,

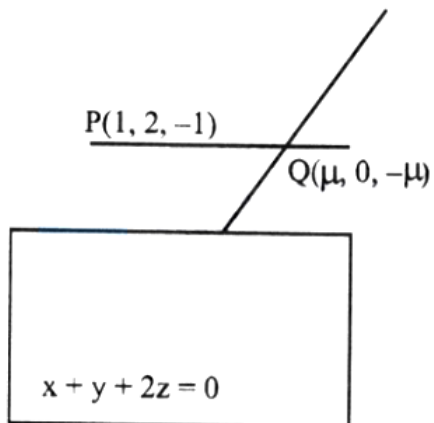

$$\therefore \vec{PQ} \cdot \vec{n} = 0$$

$$\Rightarrow \mu = -1$$

$$\Rightarrow Q(-1, 0, 1)$$

$$\vec{PN} = 2\hat{j} \text{ and } \vec{PQ} = 2\hat{i} + 2\hat{j} - 2\hat{k}$$

$$\Rightarrow \cos \alpha = \frac{1}{\sqrt{3}}$$

115. If the number of available constraints is 3 and the number of parameters to be optimise is 4, then

- A. the objective function can be optimised
- B. the constraint are short in number
- C. the solution is problem oriented
- D. None of the above

Ans. B

Solution:

To optimised n number of parameters, we need atleast n constraints.

116. The probability of getting 10 in a single throw of three fair dice is

- A. $1/6$
- B. $1/8$
- C. $1/9$
- D. $1/5$

Ans. B

Solution:

Total outcomes = 216

Now, number of cases of getting 10 from 3 dices in single throw are

$$\text{Case 1 : } 1 + 3 + 6 \rightarrow \text{outcomes} = 3! = 6$$

$$\text{Case 2 : } 1 + 4 + 5 \rightarrow \text{outcomes} = 3! = 6$$

$$\text{Case 3 : } 2 + 2 + 6 \rightarrow \text{outcomes} = \frac{3!}{2!} = 3$$

$$\text{Case 4 : } 2 + 3 + 5 \rightarrow \text{outcomes} = 3! = 6$$

$$\text{Case 5 : } 2 + 4 + 4 \rightarrow \text{outcomes} = \frac{3!}{2!} = 3$$

$$\text{Case 6 : } 3 + 3 + 4 \rightarrow \text{outcomes} = \frac{3!}{2!} = 3$$

$$\text{Favourable outcomes} = 27$$

$$\therefore \text{Probability} = \frac{27}{216} = \frac{1}{8}$$

$$\Rightarrow (x + 24)(x - 20) = 0$$

$$\Rightarrow x = 20$$

117. In a binomial distribution, the mean is 4 and variance is 3. Then, its mode is

A. 5

B. 6

C. 4

D. None of these

Ans. C

Solution:

$$\begin{aligned}\text{Mean} &= np = 4 \\ \text{Variance} &= npq = 3 \\ \Rightarrow q &= \frac{3}{4}\end{aligned}$$

and

$$p = 1 - q = 1 - \frac{3}{4} = \frac{1}{4}$$

$$\Rightarrow n = 16$$

Now, Mode of Binomial distribution is given by $(n + 1)P$

Case I If $(n + 1)P = \text{Integer}(I)$, then Mode = $\{I, I - 1\}$

Case II If $(n + 1)P \neq \text{Integer}(I + f)$, then Mode = $\{I\}$

$$\begin{aligned}\therefore (n + 1)P &= (16 + 1)\frac{1}{4} \\ &= \frac{17}{4} = 4.25 \\ &= 4 + 0.25 \\ \Rightarrow \text{Mode} &= 4\end{aligned}$$

118. The probability that certain electronic component fails when first used is 0.10. If it does not fail immediately, the probability that it lasts for one year is 0.99. The probability that a new component will last for one year is

- A. 0.9
- B. 0.01
- C. 0.119
- D. 0.891

Ans. D

Solution:

P (The electronic component fails when first

$$\text{used}) = P(F) = 0.10$$

$$\therefore P(\bar{F}) = 1 - P(F) = 0.90$$

Let E be the event that a new component will last for one year, then

$$P(E) = P(F) \cdot P\left(\frac{E}{F}\right) + P(\bar{F})P\left(\frac{E}{\bar{F}}\right)$$

[Total probability theorem]

$$= 0.10 \times 0 + 0.90 \times 0.99 = 0.891$$

119. Given below is the distribution of a random variable X

$X = x$	1	2	3	4
$P(X = x)$	λ	2λ	3λ	4λ

If $\alpha = P(X < 3)$ and $\beta = P(X > 2)$, then $\alpha : \beta =$

- A. 2:5
- B. 3:4
- C. 4:5
- D. 3:7

Ans. D

Solution:

$$\text{For a distribution of random variable } x, \alpha = P(X^6 < 3) = P(X^6 = 1) + P(X^6 = 2)$$

$$= \lambda + 2\lambda = 3\lambda$$

$$\text{and } \beta = P(X^6 < 2) = P(X^6 = 3) + P(X^6 = 4)$$

$$= 3\lambda + 4\lambda = 7\lambda$$

$$\therefore \alpha : \beta = 3 : 7$$

120. A book contains 1000 pages. A page is chosen at random. The probability that the sum of the digits of the marked number on the page is equal to 9, is

- A. 23/500
- B. 11/200
- C. 7/100
- D. None of these

Ans. B

Solution:

$$n(S) = \text{Total number of ways} = 1000$$

The favourable cases that the sum of the digits of the marked number on the page is equal to 9 are one digit number or two digits numbers or three digits numbers, if three digit number is abc.

Then,

$$a + b + c = 9; 0 \leq a, b, c \leq 9.$$

$$\therefore n(E) = \text{Number of favourable ways}$$

$$= \text{Number of solutions of the equation}$$

$$= {}^{9+3-1}C_{3-1} = {}^{11}C_2 = 55$$

$$\therefore \text{Required probability}$$

$$= \frac{n(E)}{n(S)} = \frac{55}{1000} = \frac{11}{200}$$

121. For two events A and B, if $P(A) = P(A/B) = 1/4$ and $P(B/A) = 1/2$, then which of the following is not true?

- A. A and B are independent
- B. $P(A'/B) = 3/4$
- C. $P(B'/A') = 1/2$
- D. None of these

Ans. D

Solution:

$$P\left(\frac{B}{A}\right) = \frac{1}{2} \Rightarrow \frac{P(B \cap A)}{P(A)} = \frac{1}{2} \Rightarrow P(B \cap A) = \frac{1}{8}$$

$$P\left(\frac{A}{B}\right) = \frac{1}{4} \Rightarrow \frac{P(A \cap B)}{P(B)} = \frac{1}{4} \Rightarrow P(B) = \frac{1}{2}$$

$$P(A \cap B) = \frac{1}{8} = P(A) \cdot P(B)$$

∴ Events A and B are independent.

$$\text{Now, } P\left(\frac{A'}{B}\right) = \frac{P(A \cap B)}{P(B)} = \frac{P(A)P(B)}{P(B)} = \frac{3}{4}$$

$$\text{and } P\left(\frac{B'}{A'}\right) = \frac{P(B' \cap A')}{P(A')} = \frac{P(B')P(A')}{P(A')} = \frac{1}{2}$$