

# JEE Main 2024 Apr 9 (Shift 1) Question Paper

## Mathematics

---

**Question 1. Let the line  $L$  intersect the lines:**

$$x - 2 = -y = z - 1, \quad 2(x + 1) = 2(y - 1) = z + 1$$

and be parallel to the line:

$$\frac{x - 2}{3} = \frac{y - 1}{1} = \frac{z - 2}{2}.$$

**Then which of the following points lies on  $L$ ?**

1.  $(\frac{1}{3}, -1, 1)$
  2.  $(-\frac{1}{3}, 1, -1)$
  3.  $(-\frac{1}{3}, -1, -1)$
  4.  $(-\frac{1}{3}, -1, 1)$
- 

**Question 2.**

The parabola  $y^2 = 4x$  divides the area of the circle  $x^2 + y^2 = 5$  in two parts. The area of the smaller part is equal to:

1.  $\frac{2}{3} + 5 \sin^{-1} \left( \frac{2}{\sqrt{5}} \right)$
2.  $\frac{1}{3} + 5 \sin^{-1} \left( \frac{2}{\sqrt{5}} \right)$
3.  $\frac{1}{3} + \sqrt{5} \sin^{-1} \left( \frac{2}{\sqrt{5}} \right)$
4.  $\frac{2}{3} + \sqrt{5} \sin^{-1} \left( \frac{2}{\sqrt{5}} \right)$

---

**Question 3.**

The solution curve of the differential equation

$$2y \frac{dy}{dx} + 3 = 5 \frac{dy}{dx},$$

passing through the point  $(0, 1)$ , is a conic whose vertex lies on the line:

1.  $2x + 3y = 9$
2.  $2x + 3y = -9$
3.  $2x + 3y = -6$
4.  $2x + 3y = 6$

---

**Question 4.**

A ray of light coming from the point  $P(1, 2)$  gets reflected from the point  $Q$  on the  $x$ -axis and then passes through the point  $R(4, 3)$ . If the point  $S(h, k)$  is such that  $PQRS$  is a parallelogram, then  $hk^2$  is equal to:

1. 80
2. 90
3. 60
4. 70

---

**Question 5.**

Let  $\lambda, \mu \in \mathbb{R}$ . If the system of equations

$$3x + 5y + \lambda z = 3,$$

$$7x + 11y - 9z = 2,$$

$$97x + 155y - 189z = \mu$$

has infinitely many solutions, then  $\mu + 2\lambda$  is equal to:

1. 25

2. 24

3. 27

4. 22

---

**Question 6.**

The coefficient of  $x^{70}$  in

$$x^2(1+x)^{98} + x^3(1+x)^{97} + x^4(1+x)^{96} + \dots + x^{54}(1+x)^{46}$$

is  $\binom{99}{p} - \binom{46}{q}$ . Then a possible value of  $p + q$  is:

1. 55

2. 61

3. 68

4. 83

---

**Question 7.**

Let

$$\int \frac{2 - \tan x}{3 + \tan x} dx = \frac{1}{2} (\alpha x + \log_e |\beta \sin x + \gamma \cos x|) + C,$$

where  $C$  is the constant of integration. Then  $\alpha + \frac{\gamma}{\beta}$  is equal to:

1. 3

2. 1

3. 4

4. 7

---

**Question 8.**

A variable line  $L$  passes through the point  $(3, 5)$  and intersects the positive coordinate axes at the points  $A$  and  $B$ . The minimum area of the triangle  $OAB$ , where  $O$  is the origin, is:

1. 30

2. 25

3. 40

4. 35

---

**Question 9.**

Let

$$|\cos \theta \cos(60 - \theta) \cos(60 + \theta)| \leq \frac{1}{8}, \quad \theta \in [0, 2\pi].$$

Then, the sum of all  $\theta \in [0, 2\pi]$ , where  $\cos 3\theta$  attains its maximum value, is:

1.  $9\pi$

2.  $18\pi$

3.  $6\pi$

4.  $15\pi$

---

**Question 10.**

Let

$$\vec{OA} = 2\vec{a}, \quad \vec{OB} = 6\vec{a} + 5\vec{b}, \quad \text{and} \quad \vec{OC} = 3\vec{b},$$

where  $O$  is the origin. If the area of the parallelogram with adjacent sides  $\vec{OA}$  and  $\vec{OC}$  is 15 sq. units, then the area (in sq. units) of the quadrilateral  $OABC$  is equal to:

1. 38

2. 40

3. 32

4. 35

---

**Question 11.**

If the domain of the function

$$f(x) = \sin^{-1} \left( \frac{x-1}{2x+3} \right)$$

is  $\mathbb{R} - (\alpha, \beta)$ , then  $12\alpha\beta$  is equal to:

1. 36
  2. 24
  3. 40
  4. 32
- 

**Question 12.**

If the sum of the series

$$\frac{1}{1 \cdot (1+d)} + \frac{1}{(1+d)(1+2d)} + \frac{1}{(1+2d)(1+3d)} + \cdots + \frac{1}{(1+9d)(1+10d)}$$

is equal to 5, then  $50d$  is equal to:

1. 20
  2. 5
  3. 15
  4. 10
- 

**Question 13.**

Let

$$f(x) = ax^3 + bx^2 + cx + 41$$

be such that  $f(1) = 40$ ,  $f'(1) = 2$ , and  $f''(1) = 4$ . Then  $a^2 + b^2 + c^2$  is equal to:

1. 62
  2. 73
  3. 54
  4. 51
- 

**Question 14.**

Let a circle passing through  $(2, 0)$  have its center at the point  $(h, k)$ . Let  $(x_c, y_c)$  be the point of intersection of the lines  $3x + 5y = 1$  and  $(2+c)x + 5c^2y = 1$ . If  $h = \lim_{c \rightarrow 1} x_c$  and  $k = \lim_{c \rightarrow 1} y_c$ , then the equation of the circle is:

1.  $25x^2 + 25y^2 - 20x + 2y - 60 = 0$

2.  $5x^2 + 5y^2 - 4x - 2y - 12 = 0$

3.  $25x^2 + 25y^2 - 2x + 2y - 60 = 0$

4.  $5x^2 + 5y^2 - 4x + 2y - 12 = 0$

---

**Question 15.**

The shortest distance between the lines:

$$\frac{x - 3}{4} = \frac{y + 7}{-11} = \frac{z - 1}{5} \quad \text{and} \quad \frac{x - 5}{3} = \frac{y - 9}{-6} = \frac{z + 2}{1}$$

is:

1.  $\frac{187}{\sqrt{563}}$

2.  $\frac{178}{\sqrt{563}}$

3.  $\frac{185}{\sqrt{563}}$

4.  $\frac{179}{\sqrt{563}}$

---

**Question 16.**

The frequency distribution of the age of students in a class of 40 students is given below:

Age	15	16	17	18	19	20
No. of Students	5	8	5	12	$x$	$y$

If the mean deviation about the median is 1.25, then  $4x + 5y$  is equal to:

1. 43

2. 44

3. 47

4. 46

---

**Question 17.**

The solution of the differential equation:

$$(x^2 + y^2)dx - 5xy dy = 0, \quad y(1) = 0,$$

is:

1.  $|x^2 - 4y^2|^5 = x^2$
  2.  $|x^2 - 2y^2|^6 = x$
  3.  $|x^2 - 4y^2|^6 = x$
  4.  $|x^2 - 2y^2|^5 = x^2$
- 

**Question 18.**

Let three vectors

$$\vec{a} = \alpha\hat{i} + 4\hat{j} + 2\hat{k}, \quad \vec{b} = 5\hat{i} + 3\hat{j} + 4\hat{k}, \quad \vec{c} = x\hat{i} + y\hat{j} + z\hat{k},$$

form a triangle such that  $\vec{c} = \vec{a} - \vec{b}$  and the area of the triangle is  $5\sqrt{6}$ . If  $\alpha$  is a positive real number, then  $|\vec{c}|^2$  is:

1. 16
  2. 14
  3. 12
  4. 10
- 

**Question 19.**

Let  $\alpha, \beta$  be the roots of the equation:

$$x^2 + 2\sqrt{2}x - 1 = 0.$$

The quadratic equation whose roots are  $\alpha^4 + \beta^4$  and  $\frac{1}{10}(\alpha^6 + \beta^6)$  is:

1.  $x^2 - 190x + 9466 = 0$
2.  $x^2 - 195x + 9466 = 0$

$$3. x^2 - 195x + 9506 = 0$$

$$4. x^2 - 180x + 9506 = 0$$

---

**Question 20.**

Let  $f(x) = x^2 + 9$ ,  $g(x) = \frac{x}{x-9}$ , and:

$$a = f(g(10)), \quad b = g(f(3)).$$

If  $e$  and  $\ell$  denote the eccentricity and the length of the latus rectum of the ellipse:

$$\frac{x^2}{a} + \frac{y^2}{b} = 1,$$

then  $8e^2 + \ell^2$  is equal to:

1. 16
  2. 8
  3. 6
  4. 12
- 

**Question 21.**

Let  $a, b, c$  denote the outcomes of three independent rolls of a fair tetrahedral die, whose four faces are marked 1, 2, 3, 4. If the probability that:

$$ax^2 + bx + c = 0$$

has all real roots is  $\frac{m}{n}$ , where  $\gcd(m, n) = 1$ , then  $m + n$  is equal to:

---

**Question 22.**

The sum of the square of the modulus of the elements in the set:

$$\{z = a + ib : a, b \in \mathbb{Z}, z \in \mathbb{C}, |z - 1| \leq 1, |z - 5| \leq |z - 5i|\}$$

is .....

---



**Question 23.**

Let the set of all positive values of  $\lambda$ , for which the point of local minimum of the function:

$$f(x) = (1 + x(\lambda^2 - x^2)) \quad \text{satisfies} \quad \frac{x^2 + x + 2}{x^2 + 5x + 6} < 0,$$

be  $(\alpha, \beta)$ . Then  $\alpha^2 + \beta^2$  is equal to .....

---

**Question 24.**

Let

$$\lim_{n \rightarrow \infty} \left( \frac{n}{\sqrt{n^4 + 1}} - \frac{2n}{(n^2 + 1)\sqrt{n^4 + 1}} + \frac{n}{\sqrt{n^4 + 16}} + \frac{8n}{(n^2 + 4)\sqrt{n^4 + 16}} + \dots + \frac{n}{\sqrt{n^4 + n^4}} - \frac{2n \cdot n^2}{(n^2 + n^2)\sqrt{n^4 + n^4}} \right)$$

be equal to:

$$\frac{\pi}{k},$$

using only the principal values of the inverse trigonometric functions. Then,  $k^2$  is equal to .....

---

**Question 25.**

The remainder when  $428^{2024}$  is divided by 21 is .....

---

**Question 26.**

Let  $f : (0, \pi) \rightarrow \mathbb{R}$  be a function given by:

$$f(x) = \begin{cases} \left(\frac{8}{7}\right)^{\tan 8x / \tan 7x}, & 0 < x < \frac{\pi}{2} \\ a - 8, & x = \frac{\pi}{2} \\ (1 + |\cot x|)^{\frac{b \tan |x|}{a}}, & \frac{\pi}{2} < x < \pi \end{cases}$$

where  $a, b \in \mathbb{Z}$ . If  $f$  is continuous at  $x = \frac{\pi}{2}$ , find  $a^2 + b^2$ .

---

**Question 27.**

Let  $A$  be a non-singular matrix of order 3. If:

$$\det(3\text{adj}(2\text{adj}((\det A)A))) = 3^{-13} \cdot 2^{-10},$$

and:

$$\det(3\text{adj}(2A)) = 2^m \cdot 3^n,$$

then  $|3m + 2n|$  is equal to .....

**Question 28.**

Let the centre of a circle, passing through the points  $(0, 0)$ ,  $(1, 0)$ , and touching the circle  $x^2 + y^2 = 9$ , be  $(h, k)$ . Then for all possible values of the coordinates of the centre  $(h, k)$ ,  $4(h^2 + k^2)$  is equal to .....

---

**Question 29.**

If a function  $f$  satisfies  $f(m+n) = f(m) + f(n)$  for all  $m, n \in \mathbb{N}$ , and  $f(1) = 1$ , then the largest natural number  $\lambda$  such that:

$$\sum_{k=1}^{2022} f(\lambda + k) \leq (2022)^2,$$

is equal to .....

---

**Question 30.**

Let  $A = \{2, 3, 6, 7\}$  and  $B = \{4, 5, 6, 8\}$ . Let  $R$  be a relation defined on  $A \times B$  by:

$$(a_1, b_1) R (a_2, b_2) \iff a_1 + a_2 = b_1 + b_2.$$

Then the number of elements in  $R$  is .....

---

## Physics

**Question 31.**

A proton, an electron, and an alpha particle have the same energies. Their de-Broglie wavelengths will be compared as:

1.  $\lambda_e > \lambda_\alpha > \lambda_p$
  2.  $\lambda_\alpha < \lambda_p < \lambda_e$
  3.  $\lambda_p < \lambda_e < \lambda_\alpha$
  4.  $\lambda_p > \lambda_e > \lambda_\alpha$
-

**Question 32.**

A particle moving in a straight line covers half the distance with speed 6 m/s. The other half is covered in two equal time intervals with speeds 9 m/s and 15 m/s, respectively. The average speed of the particle during the motion is:

1. 8.8 m/s
  2. 10 m/s
  3. 9.2 m/s
  4. 8 m/s
- 

**Question 33.**

A plane EM wave is propagating along the  $x$ -direction. It has a wavelength of 4 mm. If the electric field is in the  $y$ -direction with the maximum magnitude of  $60 \text{ Vm}^{-1}$ , the equation for the magnetic field is:

1.  $B_z = 60 \sin \left[ \frac{\pi}{2} (x - 3 \times 10^8 t) \right] \hat{k} \text{ T}$
  2.  $B_z = 2 \times 10^{-7} \sin \left[ \frac{\pi}{2} \times 10^3 (x - 3 \times 10^8 t) \right] \hat{k} \text{ T}$
  3.  $B_x = 60 \sin \left[ \frac{\pi}{2} (x - 3 \times 10^8 t) \right] \hat{i} \text{ T}$
  4.  $B_z = 2 \times 10^{-7} \sin \left[ \frac{\pi}{2} (x - 3 \times 10^8 t) \right] \hat{k} \text{ T}$
- 

**Question 34.**

Given below are two statements: **Statement (I):** When an object is placed at the centre of curvature of a concave lens, the image is formed at the centre of curvature of the lens on the other side.

**Statement (II):** Concave lens always forms a virtual and erect image.

In the light of the above statements, choose the correct answer from the options given below:

1. Statement I is false but Statement II is true.
2. Both Statement I and Statement II are false.

3. Statement I is true but Statement II is false.
4. Both Statement I and Statement II are true.

**Question 35.**

A light-emitting diode (LED) is fabricated using GaAs semiconducting material whose band gap is 1.42 eV. The wavelength of light emitted from the LED is:

1. 650 nm
2. 1243 nm
3. 875 nm
4. 1400 nm

**Question 36.**

A sphere of relative density  $\sigma$  and diameter  $D$  has a concentric cavity of diameter  $d$ . The ratio of  $\frac{D}{d}$ , if it just floats on water in a tank, is:

1.  $\left(\frac{\sigma}{\sigma-1}\right)^{\frac{1}{3}}$
2.  $\left(\frac{\sigma+1}{\sigma-1}\right)^{\frac{1}{3}}$
3.  $\left(\frac{\sigma-1}{\sigma}\right)^{\frac{1}{3}}$
4.  $\left(\frac{\sigma-2}{\sigma+2}\right)^{\frac{1}{3}}$

**Question 37.**

A capacitor is made of a flat plate of area  $A$  and a second plate having a stair-like structure as shown in the figure. If the area of each stair is  $\frac{A}{3}$  and the height is  $d$ , the capacitance of the arrangement is:

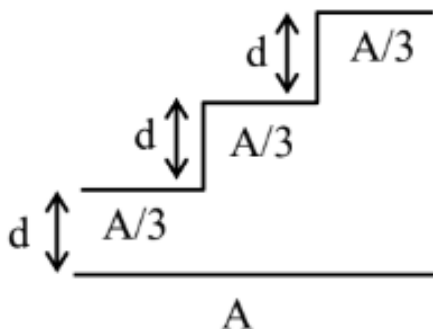

1.  $\frac{11\epsilon_0 A}{18d}$
  2.  $\frac{13\epsilon_0 A}{17d}$
  3.  $\frac{11\epsilon_0 A}{20d}$
  4.  $\frac{18\epsilon_0 A}{11d}$
- 

**Question 38.**

A light, unstretchable string passing over a smooth light pulley connects two blocks of masses  $m_1$  and  $m_2$ . If the acceleration of the system is  $\frac{g}{8}$ , then the ratio of the masses  $\frac{m_2}{m_1}$  is:

1. 9 : 7
  2. 4 : 3
  3. 5 : 3
  4. 8 : 1
- 

**Question 39.**

The dimensional formula of latent heat is:

1.  $[M^0 L T^{-2}]$
  2.  $[M L T^{-2}]$
  3.  $[M^0 L^2 T^{-2}]$
  4.  $[M L^2 T^2]$
- 

**Question 40.**

The volume of an ideal gas ( $\gamma = 1.5$ ) is changed adiabatically from 5 litres to 4 litres. The ratio of initial pressure to final pressure is:

1.  $\frac{4}{5}$
2.  $\frac{16}{25}$
3.  $\frac{8}{5\sqrt{5}}$

4.  $\frac{2}{\sqrt{5}}$

---

**Question 41.**

The energy equivalent of 1 g of substance is:

1.  $11.2 \times 10^{24}$  MeV
  2.  $5.6 \times 10^{12}$  MeV
  3. 5.6 eV
  4.  $5.6 \times 10^{26}$  MeV
- 

**Question 42.**

An astronaut takes a ball of mass  $m$  from Earth to space. He throws the ball into a circular orbit about Earth at an altitude of 318.5 km. From Earth's surface to the orbit, the change in total mechanical energy of the ball is  $x \frac{GM_e m}{21R_e}$ . The value of  $x$  is:

1. 11
  2. 9
  3. 12
  4. 10
- 

**Question 43.**

Given below are two statements:

- **Statement I:** When currents vary with time, Newton's third law is valid only if momentum carried by the electromagnetic field is taken into account.
- **Statement II:** Ampere's circuital law does not depend on Biot-Savart's law.

In the light of the above statements, choose the correct answer from the options given below:

1. Both Statement I and Statement II are false.

2. Statement I is true but Statement II is false.
  3. Statement I is false but Statement II is true.
  4. Both Statement I and Statement II are true.
- 

**Question 44.**

A particle of mass  $m$  moves on a straight line with its velocity increasing with distance according to the equation  $v = \alpha\sqrt{x}$ , where  $\alpha$  is a constant. The total work done by all the forces applied on the particle during its displacement from  $x = 0$  to  $x = d$ , will be:

1.  $\frac{m}{2\alpha^2 d}$
  2.  $\frac{md}{2\alpha^2}$
  3.  $\frac{m\alpha^2 d}{2}$
  4.  $2m\alpha^2 d$
- 

**Question 45.**

A galvanometer has a coil of resistance  $200\ \Omega$  with a full-scale deflection at  $20\ \mu\text{A}$ . The value of resistance to be added to use it as an ammeter of range  $0\text{--}20\ \text{mA}$  is:

1.  $0.40\ \Omega$
  2.  $0.20\ \Omega$
  3.  $0.50\ \Omega$
  4.  $0.10\ \Omega$
- 

**Question 46.**

A heavy iron bar, of weight  $W$ , is having its one end on the ground and the other on the shoulder of a person. The bar makes an angle  $\theta$  with the horizontal. The weight experienced by the person is:

1.  $\frac{W}{2}$
2.  $W$

3.  $W \cos \theta$

4.  $W \sin \theta$

---

**Question 47.**

One main scale division of a vernier caliper is equal to  $m$  units. If  $n^{\text{th}}$  division of the main scale coincides with  $(n+1)^{\text{th}}$  division of the vernier scale, the least count of the vernier caliper is:

1.  $\frac{n}{n+1}$

2.  $\frac{m}{n+1}$

3.  $\frac{1}{n+1}$

4.  $\frac{m}{n(n+1)}$

---

**Question 48.**

A bulb and a capacitor are connected in series across an AC supply. A dielectric is then placed between the plates of the capacitor. The glow of the bulb:

1. increases

2. remains same

3. becomes zero

4. decreases

---

**Question 49.**

The equivalent resistance between  $A$  and  $B$  is:



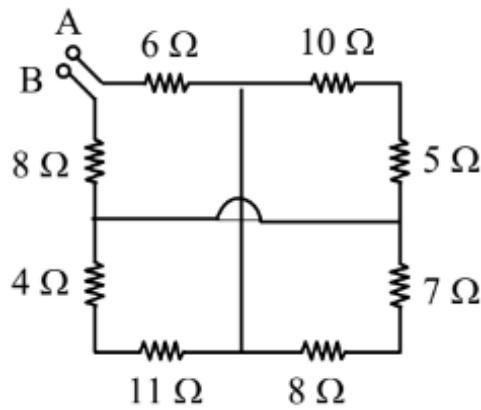

1.  $18 \Omega$
2.  $25 \Omega$
3.  $27 \Omega$
4.  $19 \Omega$

**Question 50.**

A sample of 1 mole gas at temperature  $T$  is adiabatically expanded to double its volume. If the adiabatic constant for the gas is  $\gamma = \frac{3}{2}$ , then the work done by the gas in the process is:

1.  $RT [2 - \sqrt{2}]$
2.  $\frac{R}{T} [2 - \sqrt{2}]$
3.  $RT [2 + \sqrt{2}]$
4.  $\frac{T}{R} [2 + \sqrt{2}]$

**Question 51.**

If  $\vec{a}$  and  $\vec{b}$  make an angle  $\cos^{-1} \left( \frac{5}{9} \right)$  with each other, then  $|\vec{a} + \vec{b}| = \sqrt{2}|\vec{a} - \vec{b}|$  for  $|\vec{a}| = n|\vec{b}|$ . The integer value of  $n$  is:

**Question 52.** At the centre of a half-ring of radius  $R = 10$  cm and linear charge density  $4$  nC/m, the potential is  $x\pi V$ . The value of  $x$  is \_\_\_\_\_.

---

**Question 53.**

A star has 100% helium composition. It starts to convert three  ${}^4\text{He}$  into  ${}^{12}\text{C}$  via the triple alpha process as:



The mass of the star is  $2.0 \times 10^{32}$  kg and it generates energy at the rate of  $5.808 \times 10^{30}$  W. The rate of converting these  ${}^4\text{He}$  to  ${}^{12}\text{C}$  is  $n \times 10^{42} \text{ s}^{-1}$ , where  $n$  is ..... [Take, mass of  ${}^4\text{He} = 4.0026$  u, mass of  ${}^{12}\text{C} = 12$  u].

---

**Question 54.**

In a Young's double-slit experiment, the intensity at a point is  $\frac{1}{4}$  of the maximum intensity. The minimum distance of the point from the central maximum is  $\mu\text{m}$ . (Given:  $\lambda = 600$  nm,  $d = 1.0$  mm,  $D = 1.0$  m)

---

**Question 55.**

A string is wrapped around the rim of a wheel of moment of inertia  $0.40 \text{ kgm}^2$  and radius 10 cm. The wheel is free to rotate about its axis. Initially, the wheel is at rest. The string is now pulled by a force of 40 N. The angular velocity of the wheel after 10 s is  $x$  rad/s, where  $x$  is

---

**Question 56.**

A square loop of edge length 2 m carrying a current of 2 A is placed with its edges parallel to the  $x$ - $y$ -axis. A magnetic field is passing through the  $x$ - $y$ -plane and is expressed as:

$$\vec{B} = B_0(1 + 4x)\hat{k},$$

where  $B_0 = 5$  T. The net magnetic force experienced by the loop is  $\text{N}$ .

---

**Question 57.**

Two persons pull a wire towards themselves. Each person exerts a force of 200 N on the wire. The Young's modulus of the material of the wire is  $1 \times 10^{11} \text{ N/m}^2$ . The original length of the wire is 2 m, and the area of the cross-section is  $2 \text{ cm}^2$ . The wire will extend in length by  $\mu\text{m}$ .

---

**Question 58.**

When a coil is connected across a 20 V DC supply, it draws a current of 5 A. When it is connected across a 20 V, 50 Hz AC supply, it draws a current of 4 A. The self-inductance of the coil is ..... mH. ( $\pi = 3$ )

---

**Question 59.**

The position, velocity, and acceleration of a particle executing simple harmonic motion are found to have magnitudes of 4 m,  $2 \text{ ms}^{-1}$ , and  $16 \text{ ms}^{-2}$  at a certain instant. The amplitude of the motion is  $\sqrt{x}$  m, where  $x$  is .....

---

**Question 60.**

The current flowing through the  $1 \Omega$  resistor is  $\frac{n}{10}$ . The value of  $n$  is .....

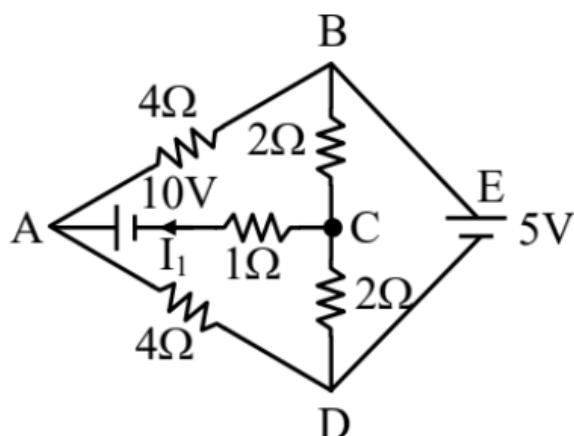

---

**1 Chemistry****Question 61.**

The molar conductivity for electrolytes  $A$  and  $B$  are plotted against  $C^{1/2}$  as shown below.

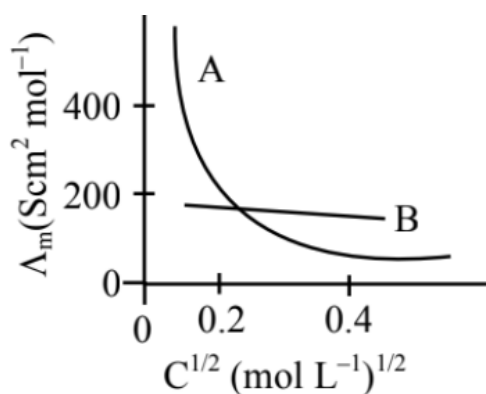

Electrolytes A and B respectively are:

	A	B
(1)	Weak electrolyte	Weak electrolyte
(2)	Strong electrolyte	Strong electrolyte
(3)	Weak electrolyte	Strong electrolyte
(4)	Strong electrolyte	Weak electrolyte

### Question 62.

Methods used for purification of organic compounds are based on:

1. neither on nature of compound nor on the impurity present.
2. nature of compound only.
3. nature of compound and presence of impurity.
4. presence of impurity only.

### Question 63.

In the following sequence of reaction, the major products B and C respectively are:

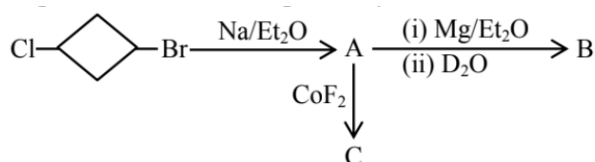

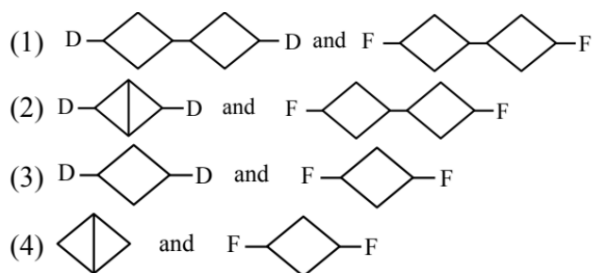

### Question 64.

The correct order of basic strength of Pyrrole , Pyridine , and Piperidine  is:

1. Piperidine > Pyridine > Pyrrole
2. Pyrrole > Pyridine > Piperidine
3. Pyridine > Piperidine > Pyrrole
4. Pyrrole > Piperidine > Pyridine

### Question 65.

In which one of the following pairs do the central atoms exhibit  $sp^2$  hybridization?

1.  $BF_3$  and  $NO_2^-$
2.  $NH_2^-$  and  $H_2O$
3.  $H_2O$  and  $NO_2$
4.  $NH_2^-$  and  $BF_3$

### Question 66.

The  $F^-$  ions make the enamel on teeth much harder by converting hydroxyapatite (the enamel on the surface of teeth) into much harder fluoroapatite having the formula:

1.  $[3(Ca_3(PO_4)_2 \cdot CaF_2)]$
2.  $[3(Ca_2(PO_4)_2 \cdot Ca(OH)_2)]$
3.  $[3(Ca_3(PO_4)_3 \cdot CaF_2)]$

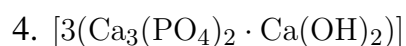

**Question 67.**

The relative stability of the contributing structures is:

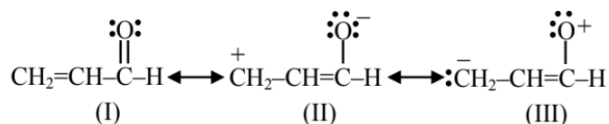

1. (I) > (III) > (II)
  2. (I) > (II) > (III)
  3. (II) > (I) > (III)
  4. (III) > (II) > (I)
- 

**Question 68.**

Given below are two statements:

- **Statement (I):** The oxidation state of an element in a particular compound is the charge acquired by its atom on the basis of electron gain enthalpy consideration from other atoms in the molecule.
- **Statement (II):**  $p\pi - p\pi$  bond formation is more prevalent in second period elements over other periods.

In the light of the above statements, choose the **most appropriate** answer from the options given below:

1. Both **Statement I** and **Statement II** are incorrect.
  2. **Statement I** is correct but **Statement II** is incorrect.
  3. Both **Statement I** and **Statement II** are correct.
  4. **Statement I** is incorrect but **Statement II** is correct.
-

### Question 69.

Given below are two statements: one is labelled as **Assertion (A)** and the other is labelled as **Reason (R)**:

- **Assertion (A):**  $S_N2$  reaction of  $C_6H_5CH_2Br$  occurs more readily than the  $S_N2$  reaction of  $CH_3CH_2Br$ .
- **Reason (R):** The partially bonded unhybridized  $p$ -orbital that develops in the trigonal bipyramidal transition state is stabilized by conjugation with the phenyl ring.

In the light of the above statements, choose the **most appropriate** answer from the options given below:

1. (A) is not correct but (R) is correct.
2. Both (A) and (R) are correct but (R) is not the correct explanation of (A).
3. Both (A) and (R) are correct and (R) is the correct explanation of (A).
4. (A) is correct but (R) is not correct.

---

### Question 70.

For the given compounds, the correct order of increasing  $pK_a$  value is:

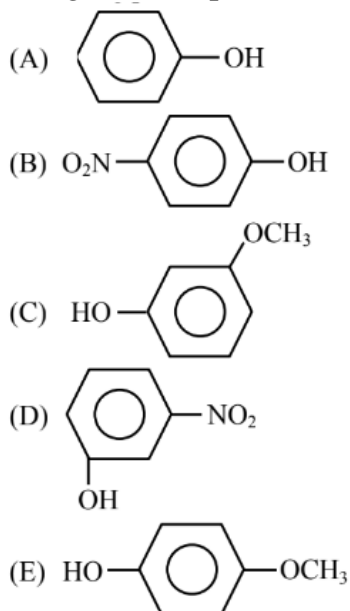

1. (E) < (D) < (C) < (B) < (A)
2. (D) < (E) < (C) < (B) < (A)

3. (E) < (D) < (B) < (A) < (C)

4. (B) < (D) < (A) < (C) < (E)

---

### Question 71.

**Assertion (A):** Both rhombic and monoclinic sulphur exist as  $S_8$ , while oxygen exists as  $O_2$ .

**Reason (R):** Oxygen forms  $p\pi-p\pi$  multiple bonds with itself and other elements having small size and high electronegativity like  $C, N$ , which is not possible for sulphur.

In the light of the above statements, choose the **most appropriate answer** from the options given below:

1. Both (A) and (R) are correct and (R) is the correct explanation of (A).
  2. Both (A) and (R) are correct but (R) is not the correct explanation of (A).
  3. (A) is correct but (R) is not correct.
  4. (A) is not correct but (R) is correct.
- 

### Question 73.

The electronic configuration of Cu(II) is  $3d^9$ , whereas that of Cu(I) is  $3d^{10}$ . Which of the following is correct?

1. Cu(II) is less stable.
  2. Stability of Cu(I) and Cu(II) depends on the nature of copper salts.
  3. Cu(II) is more stable.
  4. Cu(I) and Cu(II) are equally stable.
- 

### Question 74.



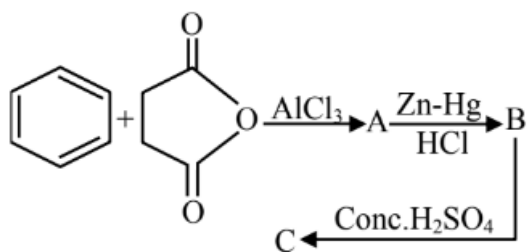

What is the structure of C?

- (1)
- (2)
- (3)
- (4)

### Question 75.

Compare the energies of the following sets of quantum numbers for a multielectron system:

- (A)  $n = 4, l = 1$
- (B)  $n = 4, l = 2$
- (C)  $n = 3, l = 1$
- (D)  $n = 3, l = 2$
- (E)  $n = 4, l = 0$

Choose the correct order of energies:

1. (B) > (A) > (C) > (E) > (D)

2. (E) > (C) < (D) < (A) < (B)
3. (E) > (C) > (A) > (D) > (B)
4. (C) < (E) < (D) < (A) < (B)

### Question 76.

Identify the major product "X" formed in the following reaction:

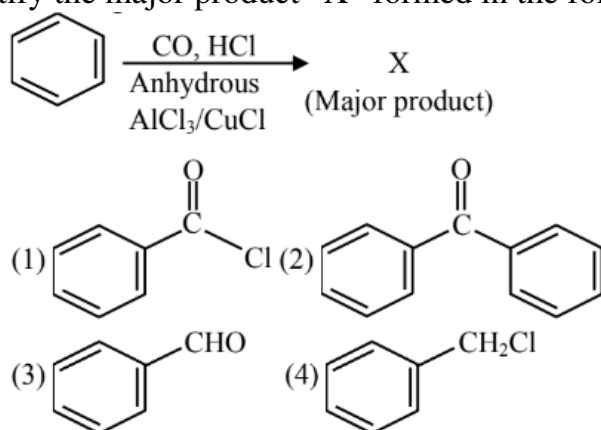

### Question 77.

Identify the product A and product B in the following set of reactions:

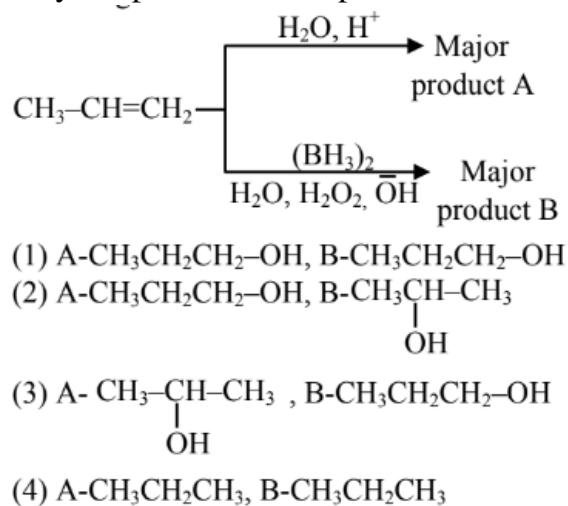

### Question 78.

On reaction of Lead Sulphide with dilute nitric acid which of the following is **not** formed?

1. Lead nitrate
2. Sulphur

3. Nitric oxide
4. Nitrous oxide

---

**Question 79.**

Identify the **incorrect** statements regarding the primary standard of titrimetric analysis:

- (A) It should be purely available in dry form.
- (B) It should not undergo chemical change in air.
- (C) It should be hygroscopic and should react with another chemical instantaneously and stoichiometrically.
- (D) It should be readily soluble in water.
- (E)  $\text{KMnO}_4$  and  $\text{NaOH}$  can be used as primary standards.

Choose the correct answer from the options given below:

1. (C) and (D) only
2. (B) and (E) only
3. (A) and (B) only
4. (C) and (E) only

---

**Question 80.**

$0.05\text{M CuSO}_4$  when treated with  $0.01\text{M K}_2\text{Cr}_2\text{O}_7$  gives a green-colored solution of  $\text{Cu}_2\text{Cr}_2\text{O}_7$ .

[SPM: Semi-Permeable Membrane]

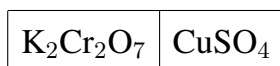

Side X SPM Side Y

Due to osmosis:

1. Green color formation observed on side Y.

- Green color formation observed on side X.
- Molarity of  $K_2Cr_2O_7$  solution is lowered.
- Molarity of  $CuSO_4$  solution is lowered.

---

**Question 81.**

The heat of solution of anhydrous  $CuSO_4$  and  $CuSO_4 \cdot 5H_2O$  are  $-70 \text{ kJ mol}^{-1}$  and  $+12 \text{ kJ mol}^{-1}$ , respectively.

The heat of hydration of  $CuSO_4$  to  $CuSO_4 \cdot 5H_2O$  is  $-x \text{ kJ}$ . The value of  $x$  is .....

---

**Question 82.****Statement I:**

The rate law for the reaction  $A + B \rightarrow C$  is  $\text{rate } (r) = k[A]^2[B]$ . When the concentration of both  $A$  and  $B$  is doubled, the reaction rate is increased “ $x$ ” times.

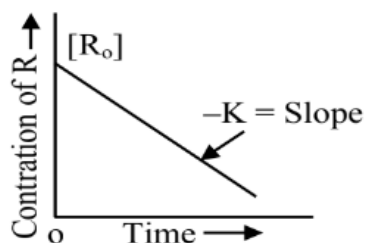
**Statement II:**

The figure shows the variation in concentration against time ( $t$ ) for a “ $y$ ” order reaction. The value of  $x + y$  is .....

---

**Question 83.**

How many compounds among the following compounds show inductive, mesomeric, as well as hyperconjugation effects?

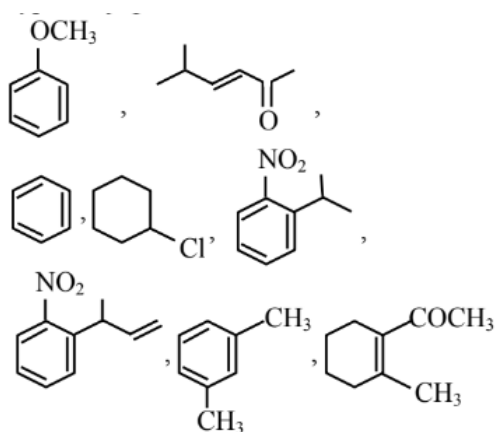

---

### Question 84.

The standard reduction potentials at 298 K for the following half-cells are given below:

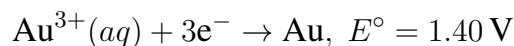
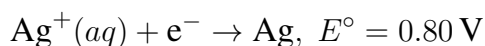
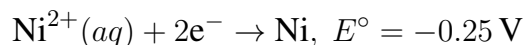
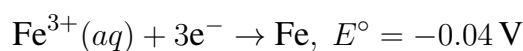

Consider the given electrochemical reactions. The number of metal(s) which will be oxidized by  $\text{Cr}_2\text{O}_7^{2-}$  in aqueous solution is .....

---

### Question 85.

When equal volume of 1M HCl and 1M  $\text{H}_2\text{SO}_4$  are separately neutralized by excess volume of 1M NaOH, X and Y kJ of heat is liberated respectively. The value of  $\frac{Y}{X}$  is .....

---

### Question 86.

Molarity (M) of an aqueous solution containing x g of anhydrous  $\text{CuSO}_4$  in 500 mL solution at  $32^\circ\text{C}$  is  $2 \times 10^{-1}$  M. Its molality will be .....  $\times 10^{-3}$  m (nearest integer). [Given: Density of the solution = 1.25 g/mL].

---

### Question 87.

The total number of species from the following in which one unpaired electron is present, is

.....

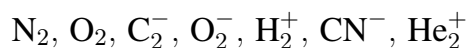

**Question 88.**

Number of ambidentate ligands among the following is.....



**Question 89.**

Total number of essential amino acids among the given list of amino acids is .....

Arginine, Phenylalanine, Aspartic acid, Cysteine, Histidine, Valine, Proline.

---

**Question 90.**

Number of colourless lanthanoid ions among the following is .....

