

## JEE Main 2024 Jan 29 (Shift 2) Question Paper

---

1. Let  $A = \begin{bmatrix} 2 & 1 & 2 \\ 6 & 2 & 11 \\ 3 & 3 & 2 \end{bmatrix}$  and  $P = \begin{bmatrix} 1 & 2 & 0 \\ 5 & 0 & 2 \\ 7 & 1 & 5 \end{bmatrix}$ . The sum of the prime factors of  $|P^{-1}AP -$

$2I|$  is equal to:

- (1) 26
  - (2) 27
  - (3) 66
  - (4) 23
- 

2. Number of ways of arranging 8 identical books into 4 identical shelves where any number of shelves may remain empty is equal to:

- (1) 18
  - (2) 16
  - (3) 12
  - (4) 15
- 

3. Let  $P(3, 2, 3)$ ,  $Q(4, 6, 2)$ , and  $R(7, 3, 2)$  be the vertices of  $\triangle PQR$ . Then, the angle  $\angle QPR$  is:

- (1)  $\frac{\pi}{6}$
  - (2)  $\cos^{-1}\left(\frac{7}{18}\right)$
  - (3)  $\cos^{-1}\left(\frac{1}{18}\right)$
  - (4)  $\frac{\pi}{3}$
- 

**4. If the mean and variance of five observations are  $\frac{24}{5}$  and  $\frac{194}{25}$  respectively, and the mean of the first four observations is  $\frac{7}{2}$ , then the variance of the first four observations is equal to:**

- (1)  $\frac{4}{5}$
  - (2)  $\frac{77}{12}$
  - (3)  $\frac{5}{4}$
  - (4)  $\frac{105}{4}$
- 

**5. The function  $f(x) = 2x + 3(x)^{\frac{2}{3}}, x \in \mathbb{R}$ , has**

- (1) exactly one point of local minima and no point of local maxima
  - (2) exactly one point of local maxima and no point of local minima
  - (3) exactly one point of local maxima and exactly one point of local minima
  - (4) exactly two points of local maxima and exactly one point of local minima
- 

**6. Let  $r$  and  $\theta$  respectively be the modulus and amplitude of the complex number  $z = 2 - i\left(2 \tan \frac{5\pi}{8}\right)$ . Then,  $(r, \theta)$  is equal to:**

- (1)  $\left(2 \sec \frac{3\pi}{8}, \frac{3\pi}{8}\right)$
- (2)  $\left(2 \sec \frac{3\pi}{8}, \frac{5\pi}{8}\right)$
- (3)  $\left(2 \sec \frac{5\pi}{8}, \frac{3\pi}{8}\right)$
- (4)  $\left(2 \sec \frac{11\pi}{8}, \frac{11\pi}{8}\right)$

---

**7. The sum of the solutions  $x \in \mathbb{R}$  of the equation**

$$\frac{3 \cos 2x + \cos^3 2x}{\cos^6 x - \sin^6 x} = x^3 - x^2 + 6$$

**is:**

- (1) 0
  - (2) 1
  - (3) -1
  - (4) 3
- 

**8. Let  $\vec{OA} = \vec{a}$ ,  $\vec{OB} = 12\vec{a} + 4\vec{b}$  and  $\vec{OC} = \vec{b}$ , where  $O$  is the origin. If  $S$  is the parallelogram with adjacent sides  $OA$  and  $OC$ , then**

$$\text{area of the quadrilateral } OABC \text{ is equal to } \frac{\text{area of } OABC}{\text{area of } S}$$

**is equal to:**

- (1) 6
  - (2) 10
  - (3) 7
  - (4) 8
- 

**9. If  $\log_e a, \log_e b, \log_e c$  are in an A.P. and  $\log_e a - \log_e 2b, \log_e 2b - \log_e 3c, \log_e 3c - \log_e a$  are also in an A.P., then  $a : b : c$  is equal to:**

- (1) 9 : 6 : 4
- (2) 16 : 4 : 1
- (3) 25 : 10 : 4
- (4) 6 : 3 : 2

---

**10. If**

$$\int \frac{\sin^3 x + \cos^3 x}{\sin^3 x \cos^3 x \cdot \sin(x - \theta)} dx = A \frac{\cos \theta \tan x - \sin \theta}{\sin^2 \theta} + B \frac{\cos \theta - \sin \theta \cot x}{\cos^2 \theta} + C,$$

where  $C$  is the integration constant, then  $AB$  is equal to:

- (1)  $4 \csc(2\theta)$
  - (2)  $4 \sec \theta$
  - (3)  $2 \sec \theta$
  - (4)  $8 \csc(2\theta)$
- 

**11. The distance of the point  $(2, 3)$  from the line  $2x - 3y + 28 = 0$ , measured parallel to the line  $\sqrt{3}x - y + 1 = 0$ , is equal to**

- (1)  $4\sqrt{2}$
  - (2)  $6\sqrt{3}$
  - (3)  $3 + 4\sqrt{2}$
  - (4)  $4 + 6\sqrt{3}$
- 

**12. If  $\sin\left(\frac{y}{x}\right) = \log_e |x| + \frac{\alpha}{2}$  is the solution of the differential equation**

$$x \cos\left(\frac{y}{x}\right) \frac{dy}{dx} = y \cos\left(\frac{y}{x}\right) + x$$

and  $y(1) = \frac{\pi}{3}$ , then  $\alpha^2$  is equal to:

- (1) 3
- (2) 12
- (3) 4
- (4) 9

---

**13. If each term of a geometric progression  $a_1, a_2, a_3, \dots$  with  $a_1 = \frac{1}{8}$  and  $a_2 \neq a_1$ , is the arithmetic mean of the next two terms and  $S_n = a_1 + a_2 + \dots + a_n$ , then  $S_{20} - S_{18}$  is equal to**

- (1)  $2^{15}$
  - (2)  $-2^{18}$
  - (3)  $2^{18}$
  - (4)  $-2^{15}$
- 

**14. Let  $A$  be the point of intersection of the lines  $3x + 2y = 14$ ,  $5x - y = 6$  and  $B$  be the point of intersection of the lines  $4x + 3y = 8$ ,  $6x + y = 5$ . The distance of the point  $P(5, -2)$  from the line  $AB$  is**

- (1)  $\frac{13}{2}$
  - (2) 8
  - (3)  $\frac{5}{2}$
  - (4) 6
- 

**15. Let  $x = \frac{m}{n}$  (where  $m$  and  $n$  are co-prime natural numbers) be a solution of the equation  $\cos(2 \sin^{-1} x) = \frac{1}{9}$  and let  $\alpha, \beta$  ( $\alpha > \beta$ ) be the roots of the equation  $mx^2 - nx - m + n = 0$ . Then the point  $(\alpha, \beta)$  lies on the line**

- (1)  $3x + 2y = 2$
  - (2)  $5x - 8y = -9$
  - (3)  $3x - 2y = -2$
  - (4)  $5x + 8y = 9$
-

**16. The function**  $f(x) = \frac{x}{x^2-6x-16}$ ,  $x \in \mathbb{R} - \{-2, 8\}$

- (1) decreases in  $(-2, 8)$  and increases in  $(-\infty, -2) \cup (8, \infty)$
  - (2) decreases in  $(-\infty, -2) \cup (-2, 8) \cup (8, \infty)$
  - (3) decreases in  $(-\infty, -2)$  and increases in  $(8, \infty)$
  - (4) increases in  $(-\infty, -2) \cup (-2, 8) \cup (8, \infty)$
- 

**17. Let**  $y = \log_e \left( \frac{1-x^2}{1+x^2} \right)$ ,  $-1 < x < 1$ . **Then at**  $x = \frac{1}{2}$ , **the value of**  $225(y' - y'')$  **is equal to**

- (1) 732
  - (2) 746
  - (3) 742
  - (4) 736
- 

**18. If**  $R$  **is the smallest equivalence relation on the set**  $\{1, 2, 3, 4\}$  **such that**  $\{(1, 2), (1, 3)\} \subseteq R$ , **then the number of elements in**  $R$  **is**

- (1) 10
  - (2) 12
  - (3) 8
  - (4) 15
- 

**19. An integer is chosen at random from the integers**  $1, 2, 3, \dots, 50$ . **The probability that the chosen integer is a multiple of at least one of**  $4, 6$ , **and**  $7$  **is**

- (1)  $\frac{8}{25}$
- (2)  $\frac{21}{50}$
- (3)  $\frac{9}{50}$
- (4)  $\frac{14}{25}$

---

**20. Let a unit vector  $\vec{u} = x\hat{i} + y\hat{j} + z\hat{k}$  make angles  $\frac{\pi}{2}$ ,  $\frac{\pi}{3}$ , and  $\frac{2\pi}{3}$  with the vectors  $\frac{1}{\sqrt{2}}\hat{i} + \frac{1}{\sqrt{2}}\hat{k}$ ,  $\frac{1}{\sqrt{2}}\hat{i} + \frac{1}{\sqrt{2}}\hat{j}$ , and  $\frac{1}{\sqrt{2}}\hat{j} + \frac{1}{\sqrt{2}}\hat{k}$  respectively. If**

$$\vec{v} = \frac{1}{\sqrt{2}}\hat{i} + \frac{1}{\sqrt{2}}\hat{j} + \frac{1}{\sqrt{2}}\hat{k},$$

**then  $|\vec{u} - \vec{v}|^2$  is equal to**

- (1)  $\frac{11}{2}$
  - (2)  $\frac{5}{2}$
  - (3) 9
  - (4) 7
- 

**21. Let  $\alpha, \beta$  be the roots of the equation  $x^2 - \sqrt{6}x + 3 = 0$  such that  $\text{Im}(\alpha) > \text{Im}(\beta)$ . Let  $a, b$  be integers not divisible by 3 and  $n$  be a natural number such that  $\frac{\alpha^{99}}{\beta} + \alpha^{98} = 3^n(a+ib)$ ,  $i = \sqrt{-1}$ . Then  $n + a + b$  is equal to**

- (1) 49
  - (2) 50
  - (3) 51
  - (4) 52
- 

**22. Let for any three distinct consecutive terms  $a, b, c$  of an A.P., the lines  $ax + by + c = 0$  be concurrent at the point  $P$  and  $Q(\alpha, \beta)$  be a point such that the system of equations**

$$x + y + z = 6,$$

$$2x + 5y + \alpha z = \beta$$

$$x + 2y + 3z = 4$$

**has infinitely many solutions. Then  $(PQ)^2$  is equal to .....**

---

**23. Let  $P(\alpha, \beta)$  be a point on the parabola  $y^2 = 4x$ . If  $P$  also lies on the chord of the parabola  $x^2 = 8y$  whose midpoint is  $(1, \frac{5}{4})$ . Then  $(\alpha - 28)(\beta - 8)$  is equal to .....**

---

**24. If  $\int_{\frac{\pi}{6}}^{\frac{\pi}{2}} \sqrt{1 - \sin 2x} dx = \alpha + \beta\sqrt{2} + \gamma\sqrt{3}$ , where  $\alpha, \beta$ , and  $\gamma$  are rational numbers, then  $3\alpha + 4\beta - \gamma$  is equal to .....**

---

**25. Let the area of the region  $\{(x, y) : 0 \leq x \leq 3, 0 \leq y \leq \min\{x^2 + 2, 2x + 2\}\}$  be  $A$ . Then  $12A$  is equal to .....**

---

**26. Let  $O$  be the origin, and  $M$  and  $N$  be the points on the lines**

$$\frac{x - 5}{4} = \frac{y - 4}{1} = \frac{z - 5}{3}$$

**and**

$$\frac{x + 8}{12} = \frac{y + 2}{5} = \frac{z + 11}{9}$$

**respectively, such that  $MN$  is the shortest distance between the given lines. Then  $\frac{OM}{ON}$  is equal to .....**

---

**27. Let**

$$f(x) = \sqrt{\lim_{r \rightarrow x} \left( \frac{2r^2 (f(r))^2 - f(x)f(r)}{r^2 - x^2} - re^{\frac{f(x)}{r}} \right)}$$

**be differentiable in  $(-\infty, 0) \cup (0, \infty)$  and  $f(1) = 1$ . Then the value of  $ea$ , such that  $f(a) = 0$ , is equal to .....**

---



28. Remainder when  $64^{32^{32}}$  is divided by 9 is equal to .....

---

29. Let the set  $C = \{(x, y) \mid x^2 - 2y = 2023, x, y \in \mathbb{N}\}$ . Then  $\sum_{(x,y) \in C} (x + y)$  is equal to .....

---

30. Let the slope of the line  $45x + 5y + 3 = 0$  be

$$\frac{27r_1 + \frac{9r_2}{2}}{3r_1}$$

for some  $r_1, r_2 \in \mathbb{R}$ . Then

$$\lim_{x \rightarrow 3} \left( \int_x^3 \frac{8t^2}{\frac{3r_1x}{2} - r_2x^2 - r_1x^3 - 3x} dt \right)$$

is equal to .....

---

31. Two sources of light emit with a power of 200 W. The ratio of the number of photons of visible light emitted by each source having wavelengths 300 nm and 500 nm respectively, will be:

- (1) 1 : 5
  - (2) 1 : 3
  - (3) 5 : 3
  - (4) 3 : 5
- 

32. The truth table for this given circuit is:

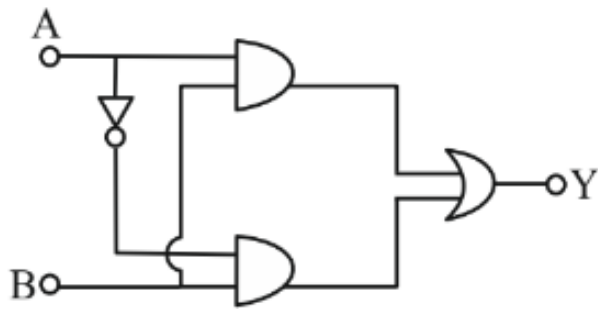

(1)

A	B	Y
0	0	1
0	1	1
1	0	1
1	1	0

(2)

A	B	Y
0	0	0
0	1	1
1	0	0
1	1	1

(3)

A	B	Y
0	0	0
0	1	0
1	0	0
1	1	1

(4)

A	B	Y
0	0	1
0	1	0
1	0	1
1	1	0

**33. A physical quantity  $Q$  is found to depend on quantities  $a, b, c$  by the relation  $Q = \frac{a^4 b^3}{c^2}$ . The percentage error in  $a, b,$  and  $c$  are 3%, 4%, and 5% respectively. Then, the percentage error in  $Q$  is:**

- (1) 66%
- (2) 43%
- (3) 34%
- (4) 14%

**34. In an a.c. circuit, voltage and current are given by:**

$$V = 100 \sin(100t) \text{ V} \quad \text{and} \quad I = 100 \sin\left(100t + \frac{\pi}{3}\right) \text{ mA}$$

**The average power dissipated in one cycle is:**

- (1) 5 W
  - (2) 10 W
  - (3) 2.5 W
  - (4) 25 W
- 

**35. The temperature of a gas having  $2.0 \times 10^{25}$  molecules per cubic meter at 1.38 atm (Given,  $k = 1.38 \times 10^{-23} \text{ J K}^{-1}$ ) is:**

- (1) 500 K
  - (2) 200 K
  - (3) 100 K
  - (4) 300 K
- 

**36. A stone of mass 900 g is tied to a string and moved in a vertical circle of radius 1 m making 10 rpm. The tension in the string, when the stone is at the lowest point is (if  $\pi^2 = 9.8$  and  $g = 9.8 \text{ m/s}^2$ )**

- (1) 97 N
  - (2) 9.8 N
  - (3) 8.82 N
  - (4) 17.8 N
- 

**37. The bob of a pendulum was released from a horizontal position. The length of the pendulum is 10 m. If it dissipates 10% of its initial energy against air resistance, the speed with which the bob arrives at the lowest point is: [Use,  $g = 10 \text{ m/s}^2$ ]**

- (1)  $6\sqrt{5} \text{ m/s}$

- (2)  $5\sqrt{6}$  m/s
  - (3)  $5\sqrt{5}$  m/s
  - (4)  $2\sqrt{5}$  m/s
- 

**38. If the distance between an object and its two times magnified virtual image produced by a curved mirror is 15 cm, the focal length of the mirror must be:**

- (1) 15 cm
  - (2) -12 cm
  - (3) -10 cm
  - (4)  $\frac{10}{3}$  cm
- 

**39. Two particles  $X$  and  $Y$  having equal charges are being accelerated through the same potential difference. Thereafter they enter normally in a region of uniform magnetic field and describe circular paths of radii  $R_1$  and  $R_2$ , respectively. The mass ratio of  $X$  and  $Y$  is:**

- (1)  $\left(\frac{R_2}{R_1}\right)^2$
  - (2)  $\left(\frac{R_1}{R_2}\right)^2$
  - (3)  $\frac{R_1}{R_2}$
  - (4)  $\frac{R_2}{R_1}$
- 

**40. In Young's double slit experiment, light from two identical sources are superimposing on a screen. The path difference between the two lights reaching at a point on the screen is  $\frac{7\lambda}{4}$ . The ratio of intensity of fringe at this point with respect to the maximum intensity of the fringe is:**

- (1)  $\frac{1}{2}$

- (2)  $\frac{3}{4}$   
 (3)  $\frac{1}{3}$   
 (4)  $\frac{1}{4}$
- 

41. A small liquid drop of radius  $R$  is divided into 27 identical liquid drops. If the surface tension is  $T$ , then the work done in the process will be:

- (1)  $8\pi R^2 T$   
 (2)  $3\pi R^2 T$   
 (3)  $\frac{1}{8}\pi R^2 T$   
 (4)  $4\pi R^2 T$
- 

42. A bob of mass  $m$  is suspended by a light string of length  $L$ . It is imparted a minimum horizontal velocity at the lowest point  $A$  such that it just completes a half circle reaching the topmost position  $B$ . The ratio of kinetic energies  $\frac{(K.E.)_A}{(K.E.)_B}$  is:

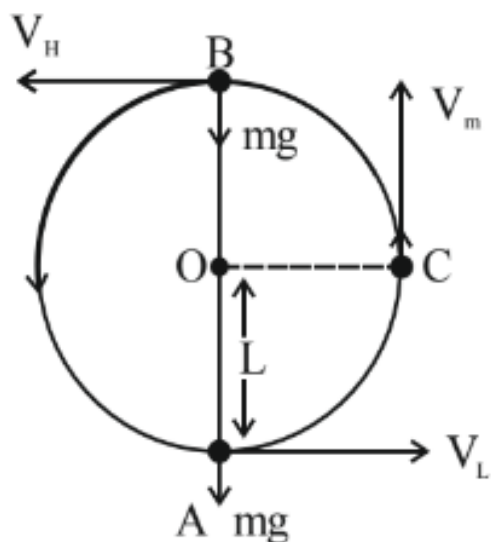

- (1)  $\frac{3}{2}$   
 (2)  $\frac{5}{1}$   
 (3)  $\frac{2}{5}$   
 (4)  $\frac{1}{5}$

---

**43. A wire of length  $L$  and radius  $r$  is clamped at one end. If its other end is pulled by a force  $F$ , its length increases by  $l$ . If the radius of the wire and the applied force both are reduced to half of their original values, keeping the original length constant, the increase in length will become:**

- (1) 3 times
  - (2)  $\frac{3}{2}$  times
  - (3) 4 times
  - (4) 2 times
- 

**44. A planet takes 200 days to complete one revolution around the Sun. If the distance of the planet from the Sun is reduced to one fourth of the original distance, how many days will it take to complete one revolution?**

- (1) 25
  - (2) 50
  - (3) 100
  - (4) 20
- 

**45. A plane electromagnetic wave of frequency 35 MHz travels in free space along the X-direction. At a particular point (in space and time)  $\vec{E} = 9.6 \hat{j}$  V/m. The value of magnetic field at this point is:**

- (1)  $3.2 \times 10^{-8} \hat{k}$  T
- (2)  $3.2 \times 10^{-8} \hat{i}$  T
- (3)  $9.6 \hat{i}$  T
- (4)  $9.6 \times 10^{-8} \hat{k}$  T

---

46. In the given circuit, the current in resistance  $R_1$  is:

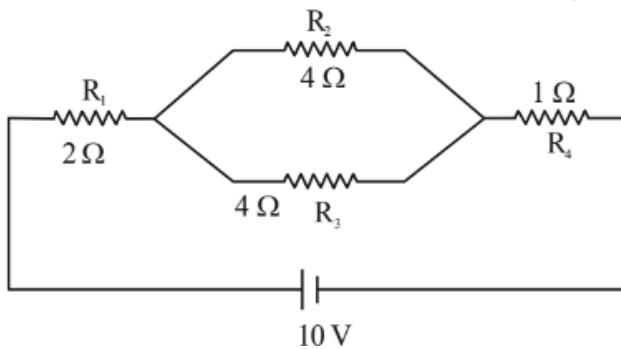

- (1) 1 A
  - (2) 1.5 A
  - (3) 2 A
  - (4) 2.5 A
- 

47. A particle is moving in a straight line. The variation of position  $x$  as a function of time  $t$  is given as  $x = (t^3 - 6t^2 + 20t + 15)$  m. The velocity of the body when its acceleration becomes zero is:

- (1) 4 m/s
  - (2) 8 m/s
  - (3) 10 m/s
  - (4) 6 m/s
- 

48.  $N$  moles of a polyatomic gas ( $f = 6$ ) must be mixed with two moles of a monoatomic gas so that the mixture behaves as a diatomic gas. The value of  $N$  is:

- (1) 6
- (2) 3
- (3) 4

(4) 2

---

**49. Given below are two statements:**

**Statement I:** Most of the mass of the atom and all its positive charge are concentrated in a tiny nucleus and the electrons revolve around it, is Rutherford's model.

**Statement II:** An atom is a spherical cloud of positive charges with electrons embedded in it, is a special case of Rutherford's model.

**In light of the above statements, choose the most appropriate from the options given below.**

- (1) Both statement I and statement II are false
  - (2) Statement I is false but statement II is true
  - (3) Statement I is true but statement II is false
  - (4) Both statement I and statement II are true
- 

**50. An electric field is given by  $\vec{E} = (6\hat{i} + 5\hat{j} + 3\hat{k}) \text{ N/C}$ . The electric flux through a surface area of  $30 \text{ m}^2$  lying in the YZ-plane (in SI units) is:**

- (1) 90
  - (2) 150
  - (3) 180
  - (4) 60
- 

**51. Two metallic wires P and Q have the same volume and are made up of the same material. If their areas of cross sections are in the ratio 4 : 1 and force  $F_1$  is applied to P, an extension of  $\Delta l$  is produced. The force which is required to produce the same extension in Q is  $F_2$ . The value of  $\frac{F_1}{F_2}$  is:**



- (1) 16
  - (2) 8
  - (3) 4
  - (4) 2
- 

**52. A horizontal straight wire 5 m long extending from east to west falling freely at right angles to the horizontal component of Earth's magnetic field  $0.60 \times 10^{-4} \text{ Wb/m}^2$ . The instantaneous value of emf induced in the wire when its velocity is 10 m/s is:**

- (1)  $1 \times 10^{-3} \text{ V}$
  - (2)  $2 \times 10^{-3} \text{ V}$
  - (3)  $3 \times 10^{-3} \text{ V}$
  - (4)  $4 \times 10^{-3} \text{ V}$
- 

**53. Hydrogen atom is bombarded with electrons accelerated through a potential difference of  $V$ , which causes excitation of hydrogen atoms. If the experiment is being performed at  $T = 0 \text{ K}$ , the minimum potential difference needed to observe any Balmer series lines in the emission spectra will be  $\frac{\alpha}{10} V$ , where  $\alpha = \dots$**

- (1) 121
  - (2) 12
  - (3) 13
  - (4) 1
- 

**54. A charge of  $4.0 \mu\text{C}$  is moving with a velocity of  $4.0 \times 10^6 \text{ ms}^{-1}$  along the positive  $y$ -axis under a magnetic field  $\vec{B}$  of strength  $(2\hat{k}) \text{ T}$ . The force acting on the charge is  $x\hat{i} \text{ N}$ . The value of  $x$  is:**

- (1) 16
  - (2) 32
  - (3) 64
  - (4) 48
- 

55. A simple harmonic oscillator has an amplitude  $A$  and time period  $6\pi$  seconds. Assuming the oscillation starts from its mean position, the time required by it to travel from  $x = A$  to  $x = \frac{\sqrt{3}}{2}A$  will be  $\frac{\pi}{x}$  s, where  $x = \dots$ :

- (1) 4
  - (2) 3
  - (3) 2
  - (4) 1
- 

56. In the given figure, the charge stored in the  $6\ \mu\text{F}$  capacitor, when points A and B are joined by a connecting wire, is  $\dots\ \mu\text{C}$ .

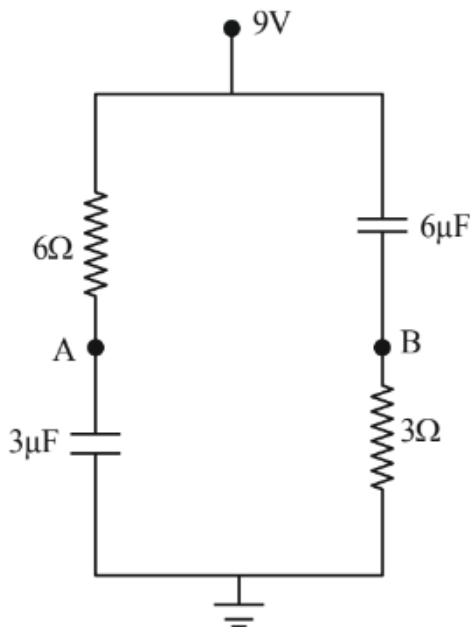

- (1) 18

- (2) 36
  - (3) 72
  - (4) 54
- 

57. In a single slit diffraction pattern, a light of wavelength  $6000 \text{ \AA}$  is used. The distance between the first and third minima in the diffraction pattern is found to be 3 mm when the screen is placed 50 cm away from slits. The width of the slit is .....  $\times 10^{-4} \text{ m}$ .

---

58. In the given circuit, the current flowing through the resistance  $20 \text{ \Omega}$  is 0.3 A, while the ammeter reads 0.9 A. The value of  $R_1$  is .....

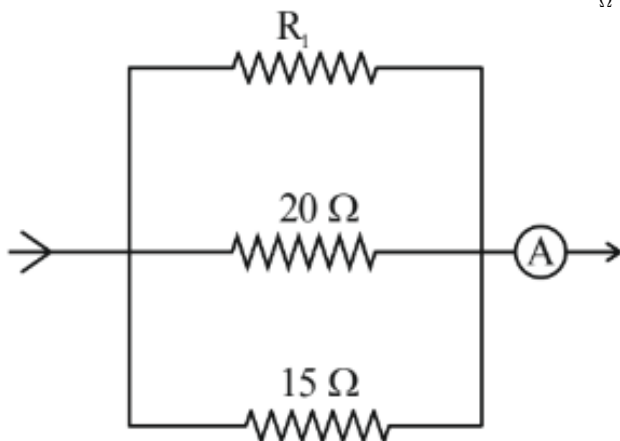

- (1) 20
  - (2) 30
  - (3) 10
  - (4) 5
- 

59. A particle is moving in a circle of radius 50 cm in such a way that at any instant the normal and tangential components of its acceleration are equal. If its speed at  $t = 0$  is 4 m/s, the time taken to complete the first revolution will be  $\frac{1}{\alpha} [1 - e^{-2\alpha t}]$  s, where  $\alpha = \dots$

---

**60. A body of mass 5 kg moving with a uniform speed  $3\sqrt{2}$  m/s in the X - Y plane along the line  $y = x + 4$ . The angular momentum of the particle about the origin will be .....  $\text{kg m}^2\text{s}^{-1}$ .**

---

**61. The ascending acidity order of the following H atoms is:**

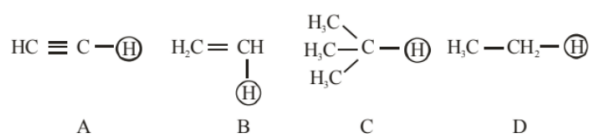

- (1)  $C < D < B < A$   
 (2)  $A < B < C < D$   
 (3)  $A < B < D < C$   
 (4)  $D < C < B < A$
- 

**62. Match List I with List II**

List I (Bio Polymer)	List II (Monomer)
A. Starch	I. nucleotide
B. Cellulose	II. $\alpha$ -glucose
C. Nucleic acid	III. $\beta$ -glucose
D. Protein	IV. $\alpha$ -amino acid

Choose the correct answer from the options given below:

- (1) A-II, B-I, C-III, D-IV  
 (2) A-IV, B-II, C-I, D-III  
 (3) A-I, B-III, C-IV, D-II  
 (4) A-II, B-III, C-I, D-IV
-

**63. Match List I with List II**

List I (Compound)	List II (pK value)
A. Ethanol	I. 10.0
B. Phenol	II. 15.9
C. m-Nitrophenol	III. 7.1
D. p-Nitrophenol	IV. 8.3

Choose the correct answer from the options given below:

- (1) A-I, B-II, C-III, D-IV
  - (2) A-IV, B-I, C-II, D-III
  - (3) A-III, B-IV, C-I, D-II
  - (4) A-II, B-I, C-IV, D-III
- 

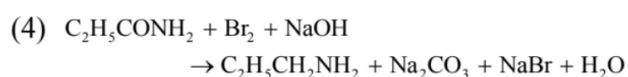
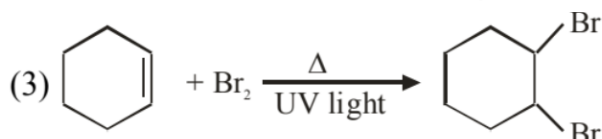
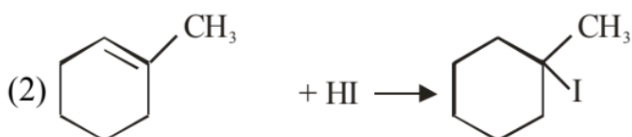
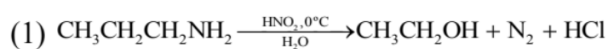
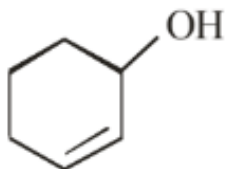
**64. Which of the following reactions is correct?****65. According to the IUPAC system, the compound shown is named as:**

- (1) Cyclohex-1-en-2-ol
- (2) 1-Hydroxyhex-2-ene

- (3) Cyclohex-1-en-3-ol
  - (4) Cyclohex-2-en-1-ol
- 

**66. The correct IUPAC name of  $\text{KMnO}_4$  is:**

- (1) Potassium tetraoxopermanganate (VI)
  - (2) Potassium tetraoxidomanganate (VI)
  - (3) Dipotassium tetraoxidomanganate (VII)
  - (4) Potassium tetraoxidomanganese (VI)
- 

**67. A reagent which gives a brilliant red precipitate with Nickel ions in a basic medium is:**

- (1) Sodium nitroprusside
  - (2) Neutral  $\text{FeCl}_3$
  - (3) Meta-dinitrobenzene
  - (4) Dimethyl glyoxime
- 

**68. Phenol treated with chloroform in the presence of sodium hydroxide, which is further hydrolyzed in the presence of an acid, results in:**

- (1) Salicylic acid
  - (2) Benzene-1,2-diol
  - (3) Benzene-1,3-diol
  - (4) 2-Hydroxybenzaldehyde
- 

**69. Match List I with List II**

List I (Spectral Series for Hydrogen)	List II (Spectral Region/Higher Energy State)
A. Lyman	I. Infrared region
B. Balmer	II. UV region
C. Paschen	III. Infrared region
D. Pfund	IV. Visible region

Choose the correct answer from the options given below:

- (1) A-II, B-III, C-I, D-IV
  - (2) A-I, B-III, C-II, D-IV
  - (3) A-II, B-IV, C-III, D-I
  - (4) A-I, B-II, C-III, D-IV
- 

**70. On passing a gas,  $X$ , through Nessler's reagent, a brown precipitate is obtained.**

**The gas  $X$  is:**

- (1)  $H_2S$
  - (2)  $CO_2$
  - (3)  $NH_3$
  - (4)  $Cl_2$
- 

**71. The product A formed in the following reaction is:**

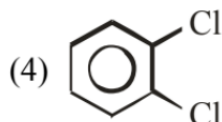
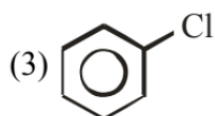
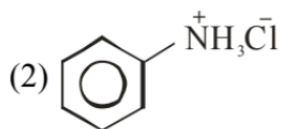
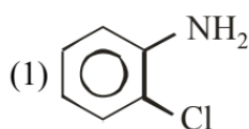
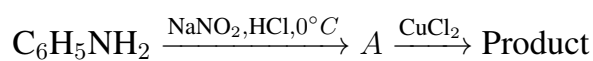

72. Identify the reagents used for the following conversion:

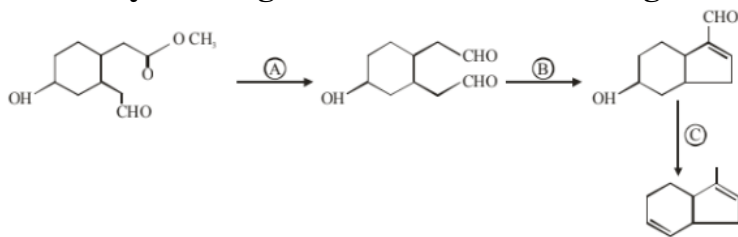

- (1) A =  $\text{LiAlH}_4$ , B =  $\text{NaOH}_{aq}$ , C =  $\text{NH}_2\text{NH}_2/\text{KOH}$ , ethylene glycol  
 (2) A =  $\text{LiAlH}_4$ , B =  $\text{NaOH}_{alc}$ , C =  $\text{Zn}/\text{HCl}$   
 (3) A = DIBAL-H, B =  $\text{NaOH}_{aq}$ , C =  $\text{NaOH}_{alc}$   
 (4) A = DIBAL-H, B =  $\text{NaOH}_{alc}$ , C =  $\text{Zn}/\text{HCl}$
- 

73. Which of the following acts as a strong reducing agent? (Atomic number: Ce = 58, Eu = 63, Gd = 64, Lu = 71)

- (1)  $\text{Lu}^{3+}$   
 (2)  $\text{Gd}^{3+}$   
 (3)  $\text{Eu}^{2+}$   
 (4)  $\text{Ce}^{4+}$
- 

74. Chromatographic technique/s based on the principle of differential adsorption is/are

- A. Column chromatography  
 B. Thin layer chromatography  
 C. Paper chromatography

Choose the most appropriate answer from the options given below:

- (1) B only  
 (2) A only  
 (3) A & B only  
 (4) C only



---

**75. Which of the following statements are correct about Zn, Cd and Hg?**

- A. They exhibit high enthalpy of atomization as the d-subshell is full.
- B. Zn and Cd do not show variable oxidation states, while Hg shows +I and +II.
- C. Compounds of Zn, Cd and Hg are paramagnetic in nature.
- D. Zn, Cd and Hg are called soft metals.

**Choose the most appropriate answer from the options given below:**

- (1) B, D only
  - (2) B, C only
  - (3) A, D only
  - (4) C, D only
- 

**76. The element having the highest first ionization enthalpy is**

- (1) Si
  - (2) Al
  - (3) N
  - (4) C
- 

**77. Alkyl halide is converted into alkyl isocyanide by reaction with**

- (1) NaCN
  - (2)  $\text{NH}_4\text{CN}$
  - (3) KCN
  - (4) AgCN
-

78. Which one of the following will show geometrical isomerism?

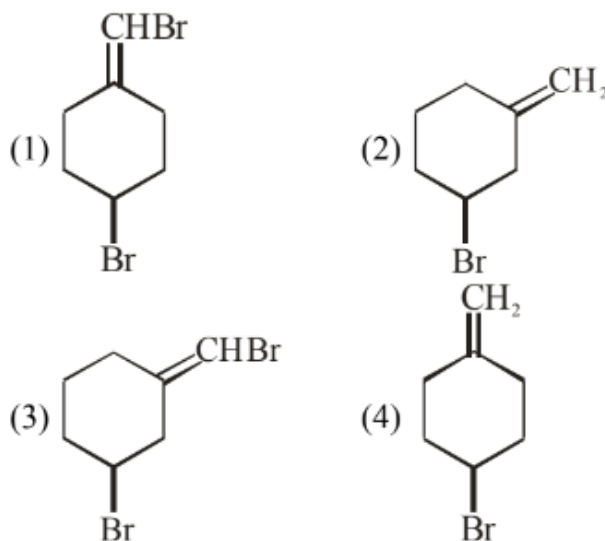

79. Given below are two statements:

**Statement I:** Fluorine has the most negative electron gain enthalpy in its group.

**Statement II:** Oxygen has the least negative electron gain enthalpy in its group.

In the light of the above statements, choose the most appropriate answer from the options given below:

- (1) Both Statement I and Statement II are true
- (2) Statement I is true but Statement II is false
- (3) Both Statement I and Statement II are false
- (4) Statement I is false but Statement II is true

80. Anomalous behaviour of oxygen is due to its

- (1) Large size and high electronegativity
- (2) Small size and low electronegativity
- (3) Small size and high electronegativity
- (4) Large size and low electronegativity

---

81. The total number of anti-bonding molecular orbitals, formed from 2s and 2p atomic orbitals in a diatomic molecule is .....

---

82. The oxidation number of iron in the compound formed during the brown ring test for  $\text{NO}_3^-$  ion is .....

---

83. The following concentrations were observed at 500 K for the formation of  $\text{NH}_3$  from  $\text{N}_2$  and  $\text{H}_2$ . At equilibrium:  $[\text{N}_2] = 2 \times 10^{-2} \text{ M}$ ,  $[\text{H}_2] = 3 \times 10^{-2} \text{ M}$ , and  $[\text{NH}_3] = 1.5 \times 10^{-2} \text{ M}$ . The equilibrium constant for the reaction is .....

---

84. The molality of 0.8 M  $\text{H}_2\text{SO}_4$  solution (density  $1.06 \text{ g cm}^{-3}$ ) is ..... $\times 10^{-3} \text{ m}$ .

---

85. If 50 mL of 0.5 M oxalic acid is required to neutralize 25 mL of NaOH solution, the amount of NaOH in 50 mL of given NaOH solution is ..... g.

---

86. The total number of 'Sigma' and Pi bonds in 2-formylhex-4-enoic acid is .....

---

87. The half-life of radioisotopic bromine - 82 is 36 hours. The fraction which remains after one day is

$\times 10^{-2}$ .

(Given antilog  $0.2006 = 1.587$ )

---

88. Standard enthalpy of vaporisation for  $\text{CCl}_4$  is  $30.5 \text{ kJ mol}^{-1}$ . Heat required for vaporisation of 284g of  $\text{CCl}_4$  at constant temperature is \_\_\_\_ kJ. (Given molar mass in  $\text{g mol}^{-1}$ ; C = 12, Cl = 35.5)

---

89. A constant current was passed through a solution of  $\text{AuCl}_4^-$  ion between gold electrodes. After a period of 10.0 minutes, the increase in mass of cathode was 1.314 g. The total charge passed through the solution is \_\_\_\_\_  $\times 10^{-2}$  F. (Given atomic mass of Au = 197)

---

90. The total number of molecules with zero dipole moment among  $\text{CH}_4$ ,  $\text{BF}_3$ ,  $\text{H}_2\text{O}$ , HF,  $\text{NH}_3$ ,  $\text{CO}_2$ , and  $\text{SO}_2$  is \_\_\_\_\_.

---

## JEE Main 29 Jan Shift 2 Answer Key

---

Question Number	Answer Key
1	1
2	4
3	4
4	3
5	3
6	1
7	3
8	4
9	1
10	4
11	4
12	1
13	4
14	4
15	4
16	2
17	4
18	1
19	2
20	2
21	1
22	4

23	2
24	3
25	3
26	1
27	2
28	1
29	3
30	2
31	1
32	1
33	2
34	4
35	1
36	1
37	1
38	2
39	3
40	3
41	3
42	1
43	3
44	1
45	2
46	2
47	2
48	2

49	30
50	60
51	1
52	4
53	4
54	2
55	4
56	2
57	4
58	4
59	3
60	3
61	3
62	4
63	3
64	3
65	1
66	3
67	4
68	3
69	4
70	3
71	4
72	1
73	417
74	815

75	4
76	22
77	63
78	56
79	2
80	3
81	4
82	1
83	417
84	815
85	4
86	22
87	63
88	56
89	2
90	3