

JEE Main - 27 Jan (Shift 1) Question Paper

Question 1. ${}^{n-1}C_r = (k^2 - 8) {}^nC_{r+1}$ if and only if:

- (1) $2\sqrt{2} < k \leq 3$
 - (2) $2\sqrt{3} < k \leq 3\sqrt{2}$
 - (3) $2\sqrt{3} < k < 3\sqrt{3}$
 - (4) $2\sqrt{2} < k < 2\sqrt{3}$
-

Question 2. The distance of the point $(7, -2, 11)$ from the line

$$\frac{x-6}{1} = \frac{y-4}{0} = \frac{z-8}{3}$$

along the line

$$\frac{x-5}{2} = \frac{y-1}{-3} = \frac{z-5}{6}$$

is:

- (1) 12
 - (2) 14
 - (3) 18
 - (4) 21
-

Question 3. Let $x = x(t)$ and $y = y(t)$ be solutions of the differential equations

$$\frac{dx}{dt} + ax = 0 \quad \text{and} \quad \frac{dy}{dt} + by = 0$$

respectively, $a, b \in \mathbb{R}$. Given that $x(0) = 2$, $y(0) = 1$ and $3y(1) = 2x(1)$, the value of t , for which $x(t) = y(t)$, is:

1. $\log_{\frac{2}{3}} 2$
 2. $\log_4 3$
 3. $\log_3 4$
 4. $\log_4 \frac{2}{3}$
-

Question 4. If (a, b) be the orthocentre of the triangle whose vertices are $(1, 2)$, $(2, 3)$, and $(3, 1)$, and

$$I_1 = \int_a^b x \sin(4x - x^2) dx, \quad I_2 = \int_a^b \sin(4x - x^2) dx$$

then $36 \frac{I_1}{I_2}$ is equal to:

- (1) 72
 - (2) 88
 - (3) 80
 - (4) 66
-

Question 5. If A denotes the sum of all the coefficients in the expansion of $(1 - 3x + 10x^2)^n$ and B denotes the sum of all the coefficients in the expansion of $(1 + x^2)^n$, then:

- (1) $A = B^3$
 - (2) $3A = B$
 - (3) $B = A^3$
 - (4) $A = 3B$
-

Question 6. The number of common terms in the progressions 4, 9, 14, 19, ..., up to 25th term and 3, 6, 9, 12, ..., up to 37th term is:

- (1) 9
 - (2) 5
 - (3) 7
 - (4) 8
-

Question 7. If the shortest distance of the parabola $y^2 = 4x$ from the centre of the circle $x^2 + y^2 - 4x - 16y + 64 = 0$ is d , then d^2 is equal to:

- (1) 16
 - (2) 24
 - (3) 20
 - (4) 36
-

Question 8. If the shortest distance between the lines

$$\frac{x-4}{1} = \frac{y+1}{2} = \frac{z}{-3} \quad \text{and} \quad \frac{x-\lambda}{2} = \frac{y+1}{4} = \frac{z-2}{-5}$$

is $\frac{6}{\sqrt{5}}$, then the sum of all possible values of λ is:

- (1) 5
 - (2) 8
 - (3) 7
 - (4) 10
-

Question 9. Evaluate the integral

$$\int_0^1 \frac{1}{\sqrt{3+x} + \sqrt{1+x}} dx$$

Given that the integral can be expressed in the form $a + b\sqrt{2} + c\sqrt{3}$, where a, b, c are rational numbers, find the value of $2a + 3b - 4c$.

- (1) 4
 - (2) 10
 - (3) 7
 - (4) 8
-

Question 10. Let $S = \{1, 2, 3, \dots, 10\}$. Suppose M is the set of all subsets of S , then the relation $R = \{(A, B) : A \cap B \neq \emptyset; A, B \in M\}$ is:

- (1) symmetric and reflexive only
 - (2) reflexive only
 - (3) symmetric and transitive only
 - (4) symmetric only
-

Question 11. If $S = \{z \in \mathbb{C} : |z - i| = |z + i| = |z - 1|\}$, then $n(S)$ is:

- (1) 1
 - (2) 0
 - (3) 3
 - (4) 2
-

Question 12. Four distinct points $(2k, 3k)$, $(1, 0)$, $(0, 0)$, and $(0, 1)$ lie on a circle for k equal to:

- (1) $\frac{2}{13}$
- (2) $\frac{3}{13}$

(3) $\frac{5}{13}$

(4) $\frac{1}{13}$

Question 13. Consider the function:

$$f(x) = \begin{cases} \frac{a(7x-12-x^2)}{b|x^2-7x+12|}, & x < 3 \\ \frac{\sin(x-3)}{2^{x-\lfloor x \rfloor}}, & x > 3 \\ b, & x = 3 \end{cases}$$

Where $\lfloor x \rfloor$ denotes the greatest integer less than or equal to x . If S denotes the set of all ordered pairs (a, b) such that $f(x)$ is continuous at $x = 3$, then the number of elements in S is:

(1) 2

(2) Infinitely many

(3) 4

(4) 1

Question 14. Let a_1, a_2, \dots, a_{10} be 10 observations such that

$$\sum_{k=1}^{10} a_k = 50 \quad \text{and} \quad \sum_{1 \leq k < j \leq 10} a_k \cdot a_j = 1100.$$

Then the standard deviation of a_1, a_2, \dots, a_{10} is equal to:

(1) 5

(2) $\sqrt{5}$

(3) 10

(4) $\sqrt{115}$

Question 15. The length of the chord of the ellipse $\frac{x^2}{25} + \frac{y^2}{16} = 1$, whose midpoint is $(1, \frac{2}{5})$, is equal to:

- (1) $\frac{\sqrt{1691}}{5}$
 - (2) $\frac{\sqrt{2009}}{5}$
 - (3) $\frac{\sqrt{1741}}{5}$
 - (4) $\frac{\sqrt{1541}}{5}$
-

Question 16. The portion of the line $4x + 5y = 20$ in the first quadrant is trisected by the lines L_1 and L_2 passing through the origin. The tangent of an angle between the lines L_1 and L_2 is:

- (1) $\frac{8}{5}$
 - (2) $\frac{25}{41}$
 - (3) $\frac{2}{5}$
 - (4) $\frac{30}{41}$
-

Question 17. Let $\vec{a} = \hat{i} + 2\hat{j} + \hat{k}$, $\vec{b} = 3(\hat{i} - \hat{j} + \hat{k})$. Let \vec{c} be the vector such that $\vec{a} \times \vec{c} = \vec{b}$ and $\vec{a} \cdot \vec{c} = 3$. Then $\vec{a} \cdot ((\vec{c} \times \vec{b}) - \vec{b} \cdot \vec{c})$ is equal to:

- (1) 32
 - (2) 24
 - (3) 20
 - (4) 36
-

Question 18. If $a = \lim_{x \rightarrow 0} \frac{\sqrt{1+\sqrt{1+x^4}}-\sqrt{2}}{x^4}$ and $b = \lim_{x \rightarrow 0} \frac{\sin^2 x}{\sqrt{2}-\sqrt{1+\cos x}}$, then the value of ab^3 is:

- (1) 36
 - (2) 32
 - (3) 25
 - (4) 30
-

Question 19. Consider the matrix $f(x) = \begin{bmatrix} \cos x & -\sin x & 0 \\ \sin x & \cos x & 0 \\ 0 & 0 & 1 \end{bmatrix}$.

Given below are two statements:

Statement I: $f(-x)$ is the inverse of the matrix $f(x)$.

Statement II: $f(x) \cdot f(y) = f(x+y)$.

In the light of the above statements, choose the correct answer from the options given below:

- (1) Statement I is false but Statement II is true
 - (2) Both Statement I and Statement II are false
 - (3) Statement I is true but Statement II is false
 - (4) Both Statement I and Statement II are true
-

Question 20. The function $f : \mathbb{N} - \{1\} \rightarrow \mathbb{N}$ defined by $f(n) =$ the highest prime factor of n , is:

- (1) both one-one and onto
- (2) one-one only
- (3) onto only
- (4) neither one-one nor onto

Question 21. The least positive integral value of α , for which the angle between the vectors $\alpha\hat{i} - 2\hat{j} + 2\hat{k}$ and $\alpha\hat{i} + 2\alpha\hat{j} - 2\hat{k}$ is acute, is:

- (1) 3
 - (2) 4
 - (3) 5
 - (4) 6
-

Question 22. Let for a differentiable function $f : (0, \infty) \rightarrow \mathbb{R}$,

$$f(x) - f(y) \geq \log_e \left(\frac{x}{y} \right) + x - y, \quad \forall x, y \in (0, \infty).$$

Then $\sum_{n=1}^{20} f' \left(\frac{1}{n} \right)$ is equal to:

- (1) 2890
 - (2) 2850
 - (3) 3000
 - (4) 2750
-

Question 23. If the solution of the differential equation

$$(2x + 3y - 2) dx + (4x + 6y - 7) dy = 0, \quad y(0) = 3,$$

is $\alpha x + \beta y + 3 \log_e |2x + 3y - \gamma| = 6$, then $\alpha + 2\beta + 3\gamma$ is equal to:

- (1) 27
 - (2) 29
 - (3) 24
 - (4) 32
-

Question 24. Let the area of the region $\{(x, y) : x - 2y + 4 \geq 0, x + 2y^2 \geq 0, x + 4y^2 \leq 8, y \geq 0\}$ be $\frac{m}{n}$, where m and n are coprime numbers. Then $m + n$ is equal to:

- (1) 100
 - (2) 119
 - (3) 137
 - (4) 145
-

Question 25. If

$$8 = 3 + \frac{1}{4}(3 + p) + \frac{1}{4^2}(3 + 2p) + \frac{1}{4^3}(3 + 3p) + \dots,$$

then the value of p is:

- (1) 7
 - (2) 8
 - (3) 9
 - (4) 10
-

Question 26. A fair die is tossed repeatedly until a six is obtained. Let X denote the number of tosses required and let $a = P(X = 3)$, $b = P(X \geq 3)$, and $c = P(X \geq 6 | X > 3)$. Then $\frac{b+c}{a}$ is equal to:

- (1) 10
 - (2) 12
 - (3) 14
 - (4) 15
-

Question 27. Let the set of all $a \in \mathbb{R}$ such that the equation $\cos 2x + a \sin x = 2a - 7$ has a solution be $[p, q]$, and $r = \tan 9^\circ - \tan 27^\circ - \frac{1}{\cot 63^\circ + \tan 81^\circ}$. Then pqr is equal to:

- (1) 30
 - (2) 40
 - (3) 48
 - (4) 50
-

Question 28. Let $f(x) = x^3 + x^2 f'(1) + x f''(2) + f'''(3)$, $x \in \mathbb{R}$. Then $f'(10)$ is equal to:

- (1) 202
 - (2) 210
 - (3) 190
 - (4) 180
-

Question 29. Let

$$A = \begin{bmatrix} 2 & 0 & 1 \\ 1 & 1 & 0 \\ 1 & 0 & 1 \end{bmatrix}, \quad B = [B_1, B_2, B_3],$$

where B_1, B_2, B_3 are column matrices, and

$$AB_1 = \begin{bmatrix} 1 \\ 0 \\ 0 \end{bmatrix}, \quad AB_2 = \begin{bmatrix} 2 \\ 3 \\ 0 \end{bmatrix}, \quad AB_3 = \begin{bmatrix} 3 \\ 2 \\ 1 \end{bmatrix}.$$

If $\alpha = |B|$ and β is the sum of all the diagonal elements of B , then $\alpha^3 + \beta^3$ is equal to:

- (1) 16

- (2) 20
 - (3) 24
 - (4) 28
-

Question 30. If α satisfies the equation $x^2+x+1 = 0$ and $(1+\alpha)^7 = A+B\alpha+C\alpha^2$, $A, B, C \geq 0$, then $5(3A - 2B - C)$ is equal to:

- (1) 10
 - (2) 5
 - (3) 15
 - (4) 20
-

Question 31. Position of an ant (S in metres) moving in the Y - Z plane is given by $S = 2t^2\hat{j} + 5t\hat{k}$ (where t is in seconds). The magnitude and direction of velocity of the ant at $t = 1$ s will be:

- (1) 16 m/s in y -direction
 - (2) 4 m/s in x -direction
 - (3) 9 m/s in z -direction
 - (4) 4 m/s in y -direction
-

Question 32. Given below are two statements:

Statement (I): Viscosity of gases is greater than that of liquids.

Statement (II): Surface tension of a liquid decreases due to the presence of insoluble impurities.

In the light of the above statements, choose the most appropriate answer from the options given below:

- (1) Statement I is correct but Statement II is incorrect
 - (2) Statement I is incorrect but Statement II is correct
 - (3) Both Statement I and Statement II are incorrect
 - (4) Both Statement I and Statement II are correct
-

Question 33 : If the refractive index of the material of a prism is $\cot\left(\frac{A}{2}\right)$, where A is the angle of the prism, then the angle of minimum deviation will be:

- (1) $\pi - 2A$
- (2) $\frac{\pi}{2} - 2A$
- (3) $\pi - A$
- (4) $\frac{\pi}{2} - A$

Question 34 : A proton moving with a constant velocity passes through a region of space without any change in its velocity. If \vec{E} and \vec{B} represent the electric and magnetic fields respectively, then the region of space may have:

- (A) $E = 0, B = 0$
- (B) $E = 0, B \neq 0$
- (C) $E \neq 0, B = 0$
- (D) $E \neq 0, B \neq 0$

Choose the most appropriate answer from the options given below:

- (1) (A), (B) and (C) only
- (2) (A), (C) and (D) only
- (3) (A), (B) and (D) only
- (4) (B), (C) and (D) only

Question 35 : The acceleration due to gravity on the surface of earth is g . If the diameter of earth reduces to half of its original value and mass remains constant, then acceleration due to gravity on the surface of earth would be:

- (1) $g/4$
- (2) $2g$
- (3) $g/2$
- (4) $4g$

Question 36 : A train is moving with a speed of 12 m/s on rails which are 1.5 m apart. To negotiate a curve of radius 400 m, the height by which the outer rail should be raised with respect to the inner rail is (Given, $g = 10 \text{ m/s}^2$):

- (1) 6.0 cm
- (2) 5.4 cm
- (3) 4.8 cm
- (4) 4.2 cm

Question 37 : Which of the following circuits is reverse-biased?

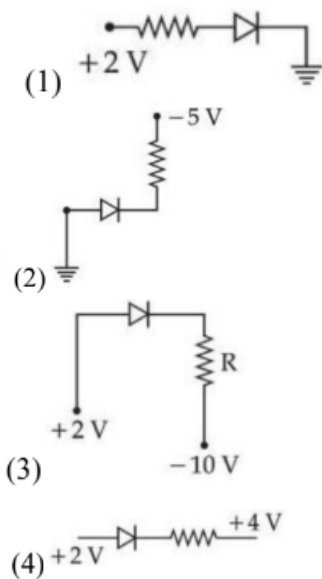

Question 38 : Identify the physical quantity that cannot be measured using a spherometer:

- (1) Radius of curvature of concave surface
- (2) Specific rotation of liquids
- (3) Thickness of thin plates
- (4) Radius of curvature of convex surface

Question 39 : Two bodies of mass 4 g and 25 g are moving with equal kinetic energies. The ratio of magnitude of their linear momenta is:

- (1) 3 : 5
- (2) 5 : 4
- (3) 2 : 5
- (4) 4 : 5

Question 40 : 0.08 kg air is heated at constant volume through 5°C . The specific heat of air at constant volume is $0.17\text{ kcal/kg}^{\circ}\text{C}$ and $J = 4.18\text{ joule/cal}$. The change in its internal energy is approximately:

- (1) 318 J
- (2) 298 J
- (3) 284 J
- (4) 142 J

Question 41 : The radius of the third stationary orbit of electron for Bohr's atom is R . The radius of fourth stationary orbit will be:

- (1) $\frac{4}{3}R$
- (2) $\frac{16}{9}R$
- (3) $\frac{3}{4}R$
- (4) $\frac{9}{16}R$

Question 42 : A rectangular loop of length 2.5 m and width 2 m is placed at 60° to a magnetic field of 4 T. The loop is removed from the field in 10 sec. The average emf induced in the loop during this time is:

- (1) -2 V
- (2) $+2\text{ V}$
- (3) $+1\text{ V}$
- (4) -1 V

Question 43 : An electric charge $10^{-6}\ \mu\text{C}$ is placed at the origin (0, 0) of an X-Y coordinate system. Two points P and Q are situated at $(\sqrt{3}, \sqrt{3})$ mm and $(\sqrt{6}, 0)$ mm respectively. The potential difference between the points P and Q will be:

- (1) $\sqrt{3}\text{ V}$
- (2) $\sqrt{6}\text{ V}$
- (3) 0 V
- (4) 3 V

Question 44 : A convex lens of focal length 40 cm forms an image of an extended source of light on a photo-electric cell. A current I is produced. The lens is replaced by another convex lens having the same diameter but focal length 20 cm. The photoelectric current now is:

- (1) $\frac{I}{2}$
- (2) $4I$
- (3) $2I$
- (4) I

Question 45 : A body of mass 1000 kg is moving horizontally with a velocity of 6 m/s. If 200 kg extra mass is added, the final velocity (in m/s) is:

- (1) 6
- (2) 2
- (3) 4
- (4) 5

Question 46 : A plane electromagnetic wave propagating in the x-direction is described by

$$E_y = (200 \text{ V m}^{-1}) \sin (1.5 \times 10^7 t - 0.05 x) ;$$

the intensity of the wave is:

- (1) 35.4 W/m²
- (2) 53.1 W/m²
- (3) 26.6 W/m²
- (4) 106.2 W/m²

Question 47 : Given below are two statements:

Statement (I): Planck's constant and angular momentum have the same dimensions.

Statement (II): Linear momentum and moment of force have the same dimensions.

In the light of the above statements, choose the correct answer from the options given below:

- (1) Statement I is true but Statement II is false
- (2) Both Statement I and Statement II are false
- (3) Both Statement I and Statement II are true
- (4) Statement I is false but Statement II is true

Question 48 : A wire of length 10 cm and radius $\sqrt{7} \times 10^{-4}$ m is connected across the right gap of a meter bridge. When a resistance of 4.5Ω is connected on the left gap by using a resistance box, the balance length is found to be at 60 cm from the left end. If the resistivity of the wire is $R \times 10^{-7} \Omega \text{ m}$, then the value of R is:

- (1) 63
- (2) 70
- (3) 66
- (4) 35

Question 49 : A wire of resistance R and length L is cut into 5 equal parts. If these parts are joined parallel, then resultant resistance will be:

- (1) $\frac{R}{25}$
- (2) $\frac{R}{5}$
- (3) $25R$
- (4) $5R$

Question 50 : The average kinetic energy of a monatomic molecule is 0.414 eV at temperature T : (Use $k_B = 1.38 \times 10^{-23} \text{ J/mol-K}$)

- (1) 3000 K
- (2) 3200 K
- (3) 1600 K
- (4) 1500 K

Question 51 : A particle starts from origin at $t = 0$ with a velocity $5\hat{i}$ m/s and moves in x-y plane under action of a force which produces a constant acceleration of $(3\hat{i} + 2\hat{j})$ m/s². If the x-coordinate of the particle at that instant is 84 m, then the speed of the particle at this time is $\sqrt{\alpha}$ m/s. The value of α is:

- (1) 625
- (2) 673
- (3) 600
- (4) 720

Question 52 : A thin metallic wire having cross sectional area of 10^{-4} m² is used to make a ring of radius 30 cm. A positive charge of 2π C is uniformly distributed over the ring, while another positive charge of 30 pC is kept at the centre of the ring. The tension in the ring is:

- (1) 32 N
- (2) 16 N
- (3) 48 N
- (4) 24 N

Question 53 : Two coils have mutual inductance 0.002 H. The current changes in the first coil according to the relation $i = i_0 \sin \omega t$, where $i_0 = 5$ A and $\omega = 50\pi$ rad/s. The maximum value of emf in the second coil is $\frac{\pi}{\alpha}$ V. The value of α is:

- (1) 4
- (2) 2
- (3) 8
- (4) 6

Question 54 : Two immiscible liquids of refractive indices $\frac{8}{5}$ and $\frac{3}{2}$ respectively are put in a beaker as shown in the figure. The height of each column is 6 cm. A coin is placed at the bottom of the beaker. For near normal vision, the apparent depth of the coin is $\frac{\alpha}{4}$ cm. The value of α is:

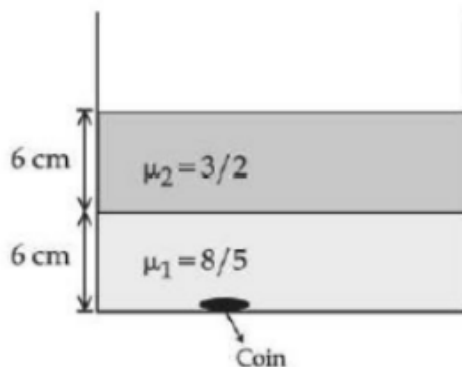

- (1) 31
- (2) 32
- (3) 24
- (4) 16

Question 55 : In a nuclear fission process, a high mass nuclide ($A \approx 236$) with binding energy 7.6 MeV/Nucleon dissociates into middle mass nuclides ($A \approx 118$), having binding energy of 8.6 MeV/Nucleon. The energy released in the process would be _____ MeV.

- (1) 224
- (2) 368
- (3) 236
- (4) 476

Question 56 : Four particles each of mass 1 kg are placed at four corners of a square of side 2 m. Moment of inertia of system about an axis perpendicular to its plane and passing through one of its vertex is _____ kg m².

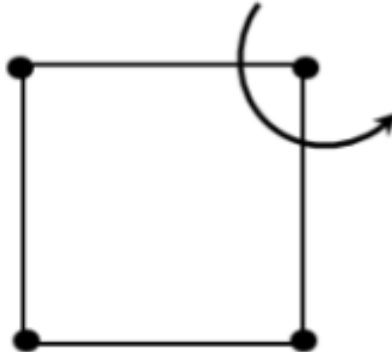

- (1) 12
- (2) 14
- (3) 16
- (4) 18

Question 57 : A particle executes simple harmonic motion with an amplitude of 4 cm. At the mean position, velocity of the particle is 10 cm/s. The distance of the particle from the mean position when its speed becomes 5 cm/s is $\sqrt{\alpha}$ cm, where $\alpha =$ _____.

- (1) 3
- (2) 4
- (3) 12
- (4) 8

Question 58 : Two long, straight wires carry equal currents in opposite directions as shown in the figure. The separation between the wires is 5.0 cm. The magnitude of the magnetic field at a point P midway between the wires is ____ μT .

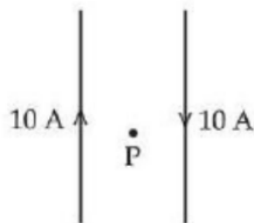

- (1) 80
- (2) 120
- (3) 160
- (4) 200

Question 59 : The charge accumulated on the capacitor connected in the following circuit is ____ μC

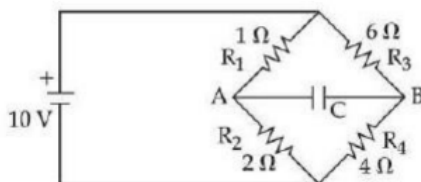

- (1) 200
- (2) 400
- (3) 600
- (4) 800

Question 60 : If average depth of an ocean is 4000 m and the bulk modulus of water is $2 \times 10^9 \text{ Nm}^{-2}$, then fractional compression $\frac{\Delta V}{V}$ of water at the bottom of ocean is $\alpha \times 10^{-2}$. The value of α is ____.

- (1) 1

- (2) 2
- (3) 3
- (4) 4

Question 61 : Two nucleotides are joined together by a linkage known as:

- (1) Phosphodiester linkage
- (2) Glycosidic linkage
- (3) Disulphide linkage
- (4) Peptide linkage

Question 62 : Highest enol content will be shown by:

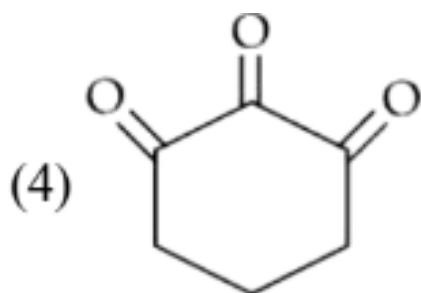
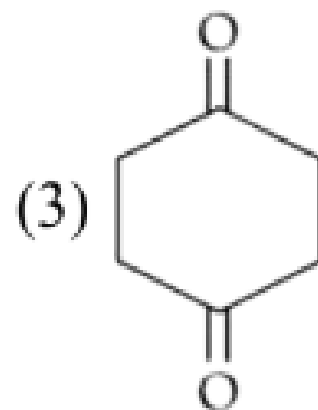
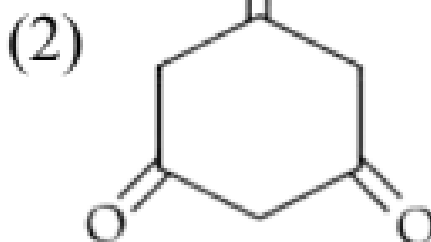
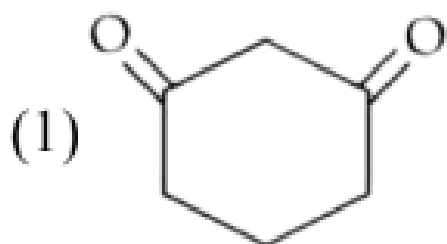

Question 63 : Element not showing variable oxidation state is:

- (1) Bromine
- (2) Iodine
- (3) Chlorine
- (4) Fluorine

Question 64 : Which of the following is strongest Bronsted base?

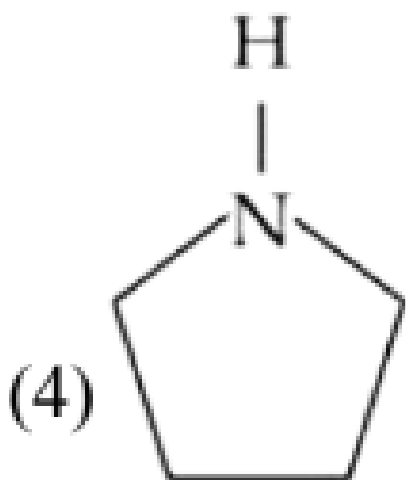
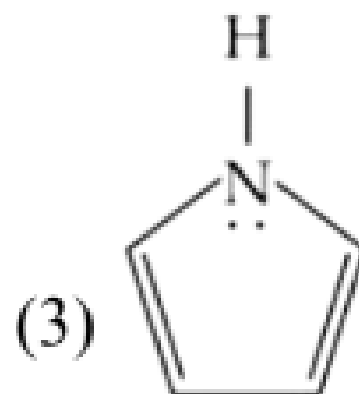
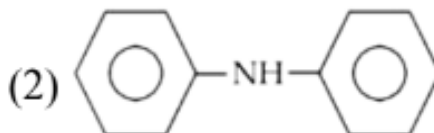
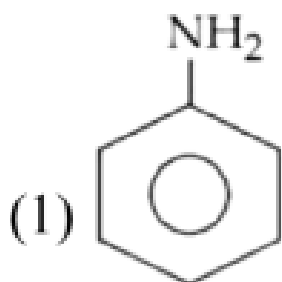

Question 65 : Which of the following electronic configuration would be associated with the highest magnetic moment?



Question 66 : Which of the following has highly acidic hydrogen?

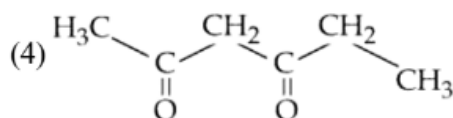
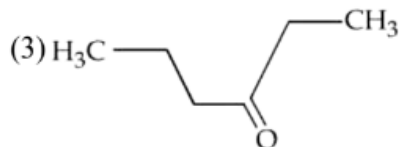
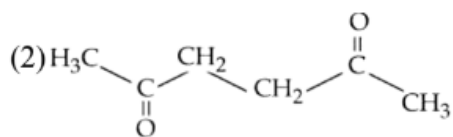
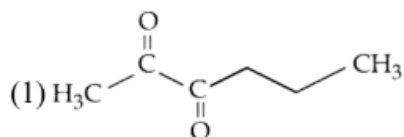

Question 67 : A solution of two miscible liquids showing negative deviation from Raoult's law will have:

- (1) Increased vapour pressure, increased boiling point
- (2) Increased vapour pressure, decreased boiling point
- (3) Decreased vapour pressure, decreased boiling point
- (4) Decreased vapour pressure, increased boiling point

Question 68 : Consider the following complex ions:

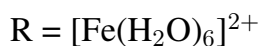
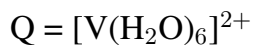

The correct order of the complex ions, according to their spin-only magnetic moment values (in B.M.), is:

- (1) $R < Q < P$
- (2) $R < P < Q$
- (3) $Q < R < P$
- (4) $Q < P < R$

Question 69 : Choose the polar molecule from the following:

- (1) CCl_4
- (2) CO_2
- (3) $\text{CH}_2=\text{CH}_2$
- (4) CHCl_3

Question 70 : Given below are two statements:

Statement I: The 4f and 5f - series of elements are placed separately in the Periodic table to preserve the principle of classification.

Statement II: s-block elements can be found in pure form in nature.

In the light of the above statements, choose the most appropriate answer from the options given below:

- (1) Statement I is false but Statement II is true
- (2) Both Statement I and Statement II are true
- (3) Statement I is true but Statement II is false
- (4) Both Statement I and Statement II are false

Question 71 : Given below are two statements:

Statement I: p-nitrophenol is more acidic than m-nitrophenol and o-nitrophenol.

Statement II: Ethanol will give immediate turbidity with Lucas reagent.

In the light of the above statements, choose the correct answer from the options given below:

- (1) Statement I is true but Statement II is false
- (2) Both Statement I and Statement II are true
- (3) Both Statement I and Statement II are false
- (4) Statement I is false but Statement II is true

Question 72 : The ascending order of acidity of –OH group in the following compounds is:

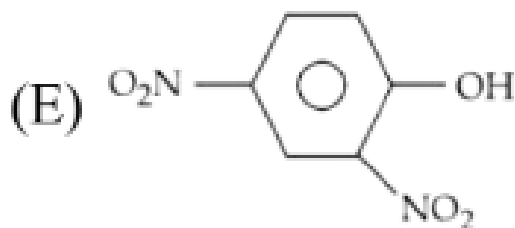
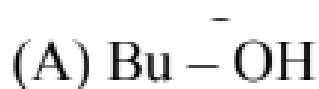

- (1) (A) < (D) < (C) < (B) < (E)
- (2) (C) < (A) < (D) < (B) < (E)
- (3) (C) < (D) < (B) < (A) < (E)
- (4) (A) < (C) < (D) < (B) < (E)

Question 73 : Given below are two statements: one is labelled as Assertion (A) and the other is labelled as Reason (R).

Assertion (A): Melting point of Boron (2453 K) is unusually high in group 13 elements.

Reason (R): Solid Boron has very strong crystalline lattice.

In the light of the above statements, choose the most appropriate answer from the options given below:

- (1) Both (A) and (R) are correct but (R) is not the correct explanation of (A)
- (2) Both (A) and (R) are correct and (R) is the correct explanation of (A)

- (3) (A) is true but (R) is false
- (4) (A) is false but (R) is true

Question 74 : Cyclohexene is ----- type of an organic compound.

- (1) Benzenoid aromatic
- (2) Benzenoid non-aromatic
- (3) Acyclic
- (4) Alicyclic

Question 75 : Yellow compound of lead chromate gets dissolved on treatment with hot NaOH solution. The product of lead formed is a:

- (1) Tetraanionic complex with coordination number six
- (2) Neutral complex with coordination number four
- (3) Dianionic complex with coordination number six
- (4) Dianionic complex with coordination number four

Question 76 : Given below are two statements:

Statement I: Aqueous solution of ammonium carbonate is basic.

Statement II: Acidic/basic nature of solution of a salt of weak acid and weak base depends on K_a and K_b values of acid and the base forming it.

In the light of the above statements, choose the most appropriate answer from the options given below:

- (1) Both Statement I and Statement II are correct
- (2) Statement I is correct but Statement II is incorrect
- (3) Both Statement I and Statement II are incorrect
- (4) Statement I is incorrect but Statement II is correct

Question 77 : IUPAC name of the following compound (P) is:

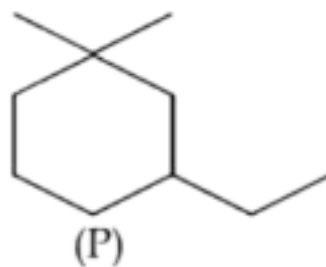

- (1) 1-Ethyl-5, 5-dimethylcyclohexane
- (2) 3-Ethyl-1,1-dimethylcyclohexane
- (3) 1-Ethyl-3, 3-dimethylcyclohexane
- (4) 1,1-Dimethyl-3-ethylcyclohexane

Question 78 : NaCl reacts with conc. H_2SO_4 and $\text{K}_2\text{Cr}_2\text{O}_7$ to give reddish fumes (B), which react with NaOH to give yellow solution (C). (B) and (C) respectively are:

- (1) CrO_2Cl_2 , Na_2CrO_4
- (2) Na_2CrO_4 , CrO_2Cl_2
- (3) CrO_2Cl_2 , KHSO_4
- (4) CrO_2Cl_2 , $\text{Na}_2\text{Cr}_2\text{O}_7$

Question 79 : The correct statement regarding nucleophilic substitution reaction in a chiral alkyl halide is:

- (1) Retention occurs in $\text{S}_{\text{N}}1$ reaction and inversion occurs in $\text{S}_{\text{N}}2$ reaction
- (2) Inversion occurs in $\text{S}_{\text{N}}1$ reaction and retention occurs in $\text{S}_{\text{N}}2$ reaction
- (3) Racemisation occurs in both $\text{S}_{\text{N}}1$ and $\text{S}_{\text{N}}2$ reactions
- (4) Racemisation occurs in $\text{S}_{\text{N}}1$ reaction and inversion occurs in $\text{S}_{\text{N}}2$ reaction

Question 80 : The electronic configuration for Neodymium is:

(Atomic Number for Neodymium 60)

- (1) [Xe] 4f⁴ 6s²
- (2) [Xe] 5f⁴7s²
- (3) [Xe] 4f⁴ 6s²
- (4) [Xe] 4f⁴5d¹6s²

Question 81 : The mass of silver (Molar mass of Ag: 108 g/mol) displaced by a quantity of electricity which displaces 5600 mL of O₂ at S.T.P. will be ----- g.

- (1) 100 g
- (2) 107 g
- (3) 110 g
- (4) 114 g

Question 82 : Consider the following data for the given reaction

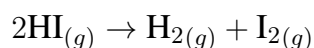

HI (mol L ⁻¹)	0.005	0.01	0.02
Rate (mol L ⁻¹ s ⁻¹)	7.5×10^{-4}	3.0×10^{-3}	1.2×10^{-2}

The order of the reaction is -----.

- (1) Zero
- (2) Second
- (3) First
- (4) Third

Question 83 : Mass of methane required to produce 22 g of CO₂ after complete combustion is ----- g.

- (1) 10
- (2) 12
- (3) 8
- (4) 6

Question 84 : If three moles of an ideal gas at 300 K expand isothermally from 30 dm^3 to 45 dm^3 against a constant opposing pressure of 80 kPa, then the amount of heat transferred is ----- J.

- (1) 1000 J
- (2) 1500 J
- (3) 1200 J
- (4) 1300 J

Question 85 : 3-Methylhex-2-ene on reaction with HBr in presence of peroxide forms an addition product (A). The number of possible stereoisomers for 'A' is

-----.

- (1) 2
- (2) 4
- (3) 3
- (4) 6

Question 86 : Among the given organic compounds, the total number of aromatic compounds is

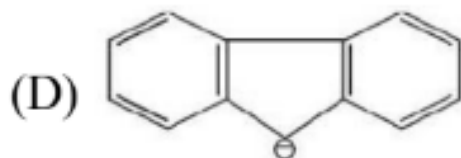
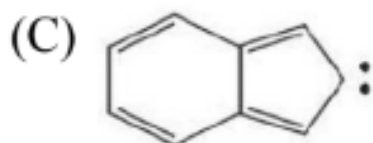
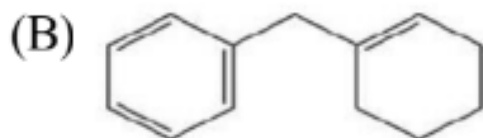
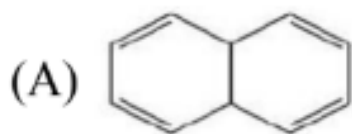

- (1) 1
- (2) 2
- (3) 3
- (4) 4

Question 87 : Among the following, total number of meta-directing functional groups is

$-\text{OCH}_3$, $-\text{NO}_2$, $-\text{CN}$, $-\text{CH}_3$, $-\text{NHCOCH}_3$, $-\text{COR}$, $-\text{OH}$, $-\text{COOH}$

- (1) 4
- (2) 3
- (3) 5
- (4) 6

Question 88 : The number of electrons present in all the completely filled subshells having $n = 4$ and $s = \pm\frac{1}{2}$ is

(Where n = principal quantum number and s = spin quantum number)

- (1) 14
- (2) 10
- (3) 16
- (4) 12

Question 89 : Sum of bond order of CO and NO^+ is

- (1) 6
- (2) 5
- (3) 4
- (4) 7

Question 90 : From the given list, the number of compounds with +4 oxidation state of Sulphur is

SO_3 , H_2SO_3 , SOCl_2 , SF_4 , BaSO_4 , $\text{H}_2\text{S}_2\text{O}_7$

- (1) 4
 - (2) 2
 - (3) 3
 - (4) 1
-

JEE Main - 27 Jan (Shift 1) Answer Key

Question Number	Answer Key
1	(1)
2	(2)
3	(4)
4	(1)
5	(1)
6	(3)
7	(3)
8	(2)
9	(4)
10	(4)
11	(1)
12	(3)
13	(4)
14	(2)
15	(1)
16	(4)
17	(2)
18	(2)
19	(4)
20	(4)
21	5
22	2890

23	29
24	119
25	9
26	12
27	48
28	202
29	28
30	5
31	(4)
32	(2)
33	(1)
34	(3)
35	(4)
36	(2)
37	(4)
38	(2)
39	(3)
40	(3)
41	(2)
42	(3)
43	(3)
44	(4)
45	(4)
46	(2)
47	(1)
48	(3)
49	(1)

50	(2)
51	673
52	3
53	2π
54	31
55	236
56	16
57	12
58	160
59	(1)
60	(4)
61	(2)
62	(3)
63	(4)
64	(1)
65	(2)
66	(3)
67	(2)
68	(4)
69	(1)
70	(3)
71	(2)
72	(4)
73	(1)
74	(3)
75	(2)
76	45

77	128
78	73
79	56
80	24
81	39
82	72
83	91
84	63
85	81
86	44
87	36
88	50
89	68
90	12