

JEE Main 2023 6 April Shift 2 Question Paper

Time Allowed :3 Hours

Maximum Marks :300

Total Questions :90

General Instructions

Read the following instructions very carefully and strictly follow them:

1. The test is of 3 hours duration.
2. The question paper consists of 90 questions, out of which 75 are to attempted.
The maximum marks are 300.
3. There are three parts in the question paper consisting of Physics, Chemistry and Mathematics having 30 questions in each part of equal weightage.
4. Each part (subject) has two sections.
 - (i) Section-A: This section contains 20 multiple choice questions which have only one correct answer. Each question carries 4 marks for correct answer and –1 mark for wrong answer.
 - (ii) Section-B: This section contains 10 questions. In Section-B, attempt any five questions out of 10. The answer to each of the questions is a numerical value. Each question carries 4 marks for correct answer and –1 mark for wrong answer. For Section-B, the answer should be rounded off to the nearest integer

MATHEMATICS

Section-A

1. If $\gcd(m, n) = 1$ and

$$1^2 - 2^2 + 3^2 - 4^2 + \dots + (2022)^2 - (2023)^2 = 1012m^2n$$

then $m^2 - n^2$ is equal to:

- (1) 180
- (2) 220

(3) 200

(4) 240

2. The area bounded by the curves $y = |x - 1| + |x - 2|$ and $y = 3$ is equal to:

(1) 5

(2) 4

(3) 6

(4) 3

3. For the system of equations

$$x + y + z = 6$$

$$x + 2y + z = 10$$

$$x + 3y + 5z = \beta$$

which one of the following is NOT true:

(1) System has a unique solution for $\alpha = 3, \beta \neq 14$

(2) System has a unique solution for $\alpha = -3, \beta = 14$

(3) System has no solution for $\alpha = 3, \beta = 24$

(4) System has infinitely many solutions for $\alpha = 3, \beta = 14$

4. Among the statements:

(S1): $(\phi \implies \psi) \vee (\neg\phi \implies \psi)$ is a tautology.

(S2): $(\psi \implies \phi) \implies (\neg\phi \implies \psi)$ is a contradiction.

Choose the correct answer from the options given below:

(1) Only (S2) is True

(2) Only (S1) is True

(3) Neither (S1) nor (S2) is True

(4) Both (S1) and (S2) are True

5. $\lim_{n \rightarrow \infty} \left\{ \left(\frac{1}{2^2 - 2^3} \right) \left(\frac{1}{2^2 - 2^5} \right) \cdots \left(\frac{1}{2^2 - 2^{2n+1}} \right) \right\}$ is equal to:

- (1) $\frac{1}{\sqrt{2}}$
 - (2) $\sqrt{2}$
 - (3) 1
 - (4) 0
-

6. Let P be a square matrix such that $P^2 = I - P$. For $\alpha, \beta, \gamma, \delta \in \mathbb{N}$, if

$P\alpha + P\beta = \gamma I - 29P$ and $P\alpha - P\beta = \delta I - 13P$, then $\alpha + \beta + \gamma - \delta$ is equal to:

- (A) 40
 - (B) 22
 - (C) 24
 - (D) 18
-

7. A plane P contains the line of intersection of the plane $\vec{r} \cdot (\hat{i} + \hat{j} + \hat{k}) = 6$ and $\vec{r} \cdot (2\hat{i} + 3\hat{j} + 4\hat{k}) = -5$. If P passes through the point $(0, 2, -2)$, then the square of distance of the point $(12, 12, 18)$ from the plane P is:

- (1) 620
 - (2) 1240
 - (3) 310
 - (4) 155
-

8. Let $f(x)$ be a function satisfying $f(x) + f(\pi - x) = \pi^2$, for all $x \in \mathbb{R}$. Then

$\int_0^\pi f(x) \sin x \, dx$ is equal to:

- (1) $\frac{\pi^2}{2}$
 - (2) π^2
 - (3) $2\pi^2$
 - (4) $\frac{\pi^2}{4}$
-

9. If the coefficients of x^7 in $(ax^2 + \frac{1}{2}bx)^{11}$ and x^7 in $(ax - \frac{1}{3}bx^2)$ are equal, then:

- (1) $64ab = 243$
- (2) $32ab = 729$
- (3) $729ab = 32$

(4) $243ab = 64$

10. If the tangents at the points P and Q on the circle $x^2 + y^2 - 2x + y = 5$ meet at the point $R\left(\frac{9}{4}, 2\right)$, then the area of triangle PQR is:

- (1) $\frac{13}{4}$
 - (2) $\frac{5}{8}$
 - (3) $\frac{5}{4}$
 - (4) $\frac{13}{8}$
-

11. Three dice are rolled. If the probability of getting different numbers on the three dice is $\frac{p}{q}$, where p and q are co-prime, then $q - p$ is equal to:

- (1) 1
 - (2) 2
 - (3) 4
 - (4) 3
-

12. In a group of 100 persons, 75 speak English and 40 speak Hindi. Each person speaks at least one of the two languages. If the number of persons, who speak only English is α and the number of persons who speak only Hindi is β , then the eccentricity of the ellipse $25(\beta^2x^2 + \alpha^2y^2) = \alpha\beta^2$ is:

- (1) $\frac{\sqrt{129}}{12}$
 - (2) $\frac{\sqrt{117}}{12}$
 - (3) $\frac{\sqrt{119}}{12}$
 - (4) $\frac{\sqrt{15}}{12}$
-

13. If the solution curve $f(x, y)$ of the differential equation $(1 + \log x)\frac{dx}{dy} - x \log x = e^y$, $x > 0$, passes through the points $(1, 0)$ and $(\alpha, 2)$, then α^4 is equal to:

- (1) e^{2e^2}
- (2) e^{e^2}
- (3) e^{e^e}
- (4) e^{2e^2}

14. Let the sets A and B denote the domain and range respectively of the function

$f(x) = \frac{1}{\sqrt{|x|-x}}$, **where $[x]$ denotes the smallest integer greater than or equal to x . Then among the statements:**

- (1) $A \cap B = (1, \infty) - N$
 - (2) $A \cup B = (1, \infty)$
 - (3) only (S1) is true
 - (4) both (S1) and (S2) are true
-

15. Let $a \neq b$ be two non-zero real numbers. Then the number of elements in the set

$X = \{z \in \mathbb{C} : \Re(az^2 + bz) = a \text{ and } \Re(bz^2 + az) = b\}$ **is equal to:**

- (1) 0
 - (2) 2
 - (3) 1
 - (4) 3
-

16. The sum of all values of α , for which the points whose position vectors are

$\hat{i} - 2\hat{j} + 3\hat{k}$, $2\hat{i} - 3\hat{j} + 4\hat{k}$, $(\alpha + 1)\hat{i} + 2\hat{k}$ **and $\hat{j} + 2\hat{k}$ are coplanar, is equal to:**

- (1) -2
 - (2) 2
 - (3) 6
 - (4) 4
-

17. Let the line L pass through the point $(0, 1, 2)$, intersect the line $\frac{x-1}{2} = \frac{y-2}{3} = \frac{z-3}{4}$ and be parallel to the plane $2x + y - 3z = 4$. Then the distance of the point $P(1, -9, 2)$ from the line L is:

- (1) 9
 - (2) $\sqrt{54}$
 - (3) $\sqrt{69}$
 - (4) $\sqrt{74}$
-

18. All the letters of the word PUBLIC are written in all possible orders and these words are written as in a dictionary with serial numbers. Then the serial number of the word PUBLIC is:

- (1) 580
 - (2) 578
 - (3) 576
 - (4) 582
-

19. Let the vectors a, b, c represent three coterminous edges of a parallelepiped of volume V . Then the volume of the parallelepiped, whose coterminous edges are represented by $a + b + c$ and $a + 2b + 3c$, is equal to:

- (1) $2V$
 - (2) $6V$
 - (3) $3V$
 - (4) V
-

20. Among the statements:

(S1): $2023^{2022} - 1999^{2022}$ is divisible by 8

(S2): $13(13^n - 1) - 13$ is divisible by 144 for infinitely many $n \in \mathbb{N}$

Then:

- (1) only (S1) is correct
 - (2) only (S2) is correct
 - (3) both (S1) and (S2) are incorrect
 - (4) both (S1) and (S2) are correct
-

SECTION-B

21. The value of $\tan 9^\circ - \tan 27^\circ - \tan 63^\circ + \tan 81^\circ$ is _____ :

22. If $(20)^{19} + 2(21)(20)^{18} + 3(21)^2(20)^{17} + \dots + 20(21)^{19} = k(20)^{19}$, then k is equal to _____ :

23. Let the eccentricity of an ellipse $\frac{x^2}{a^2} + \frac{y^2}{b^2} = 1$ be reciprocal to that of the hyperbola

$2x^2 - 2y^2 = 1$. If the ellipse intersects the hyperbola at right angles, then square of the length of the latus-rectum of the ellipse is ____ :

24. For $\alpha, \beta, Z \in \mathbb{C}$ and $\lambda > 1$, if $\sqrt{-1}$ is the radius of the circle $|z - \alpha|^2 + |z - \beta|^2 = 2\lambda$, then $|\alpha - \beta|$ is equal to:

25. Let a curve $y = f(x)$, $x \in (0, \infty)$ pass through the points $P(1, \frac{3}{2})$ and $Q(a, \frac{1}{2})$. If the tangent at any point $R(b, f(b))$ to the given curve cuts the y-axis at the points $S(0, c)$ such that $bc = 3$, then PQ^2 is equal to ____ :

26. If the lines $\frac{x-1}{2} = \frac{y-3}{-3} = \frac{z-3}{\alpha}$ and $\frac{x-4}{5} = \frac{y-1}{2} = \frac{z}{\beta}$ intersect, then the magnitude of the minimum value of $8\alpha\beta$ is :

27. Let $f(x) = \frac{x}{1+x^n}$, $x \in \mathbb{R} - \{-1\}$, $n \in \mathbb{N}$, $n > 2$. If $f^n(x) = n(f(f(\dots f(x))))(x)$, then $\lim_{n \rightarrow \infty} \int_0^1 x^{n-2}(f^n(x)) dx$ is equal to:

28. If the mean and variance of the frequency distribution:

x_i	2	4	6	8	10	12	14	16
f_i	4	4	α	15	8	β	4	5

are 9 and 15.08 respectively, then the value of $\alpha^2 + \beta^2 - \alpha\beta$ is:

29. The number of points, where the curve $y = x^5 - 20x^3 + 50x + 2$ crosses the x-axis is :

30. The number of 4-letter words, with or without meaning, each consisting of 2 vowels and 2 consonants, which can be formed from the letters of the word UNIVERSE without repetition is :

PHYSICS

Section-A

31. The temperature of an ideal gas is increased from 200 K to 800 K. If r.m.s. speed of gas at 200 K is v_0 , then the r.m.s. speed of the gas at 800 K will be:

- (1) $4v_0$
 - (2) $2v_0$
 - (3) v_0
 - (4) $\frac{v_0}{4}$
-

32. Given below are two statements: one is labelled as assertion A and the other is labelled as Reason R.

Assertion A: The phase difference of two light waves change if they travel through different media having same thickness, but different indices of refraction.

Reason R: The wavelengths of waves are different in different media.

In the light of the above statements, choose the most appropriate answer from the options given below:

- (1) Both A and R are correct and R is the correct explanation of A
 - (2) A is not correct but R is correct
 - (3) A is correct but R is not correct
 - (4) Both A and R are correct but R is NOT the correct explanation of A
-

33. For an amplitude modulated wave, the minimum amplitude is 3 V, while the modulation index is 60%. The maximum amplitude of the modulated wave is:

- (1) 10 V
 - (2) 12 V
 - (3) 15 V
 - (4) 5 V
-

34. The ratio of speed of sound in hydrogen gas to the speed of sound in oxygen gas at the same temperature is:

- (1) 1 : 4
- (2) 1 : 2
- (3) 1 : 1
- (4) 4 : 1

35. A dipole comprises of two charged particles of identical magnitude q and opposite in nature. The mass m of the positive charged particle is half of the mass of the negative charged particle. The two charges are separated by a distance l . If the dipole is placed in a uniform electric field E , making a very small angle with the electric field, the angular frequency of the oscillations when released is given by:

- (1) $\frac{4qE}{3ml}$
- (2) $\frac{8qE}{ml}$
- (3) $\frac{8qE}{3ml}$
- (4) $\frac{4qE}{ml}$

36. Given below are two statements: one is labelled as Assertion A and the other is labelled as Reason R.

Assertion A: When you squeeze one end of a tube to get toothpaste out from the other end, Pascal's principle is observed.

Reason R: A change in the pressure applied to an enclosed incompressible fluid is transmitted undiminished to every portion of the fluid and to the walls of its container.

In the light of the above statements, choose the most appropriate answer from the options given below:

- (1) A is correct but R is not correct
- (2) Both A and R are correct and R is the correct explanation of A
- (3) A is not correct but R is correct
- (4) Both A and R are correct but R is NOT the correct explanation of A

37. A student is provided with a variable voltage source V , a test resistor $R_T = 10\ \Omega$, two identical galvanometers G_1 and G_2 , and two additional resistors, $R_1 = 10M\ \Omega$ and $R_2 = 0.001\ \Omega$. For conducting an experiment to verify ohm's law, the most suitable circuit is:

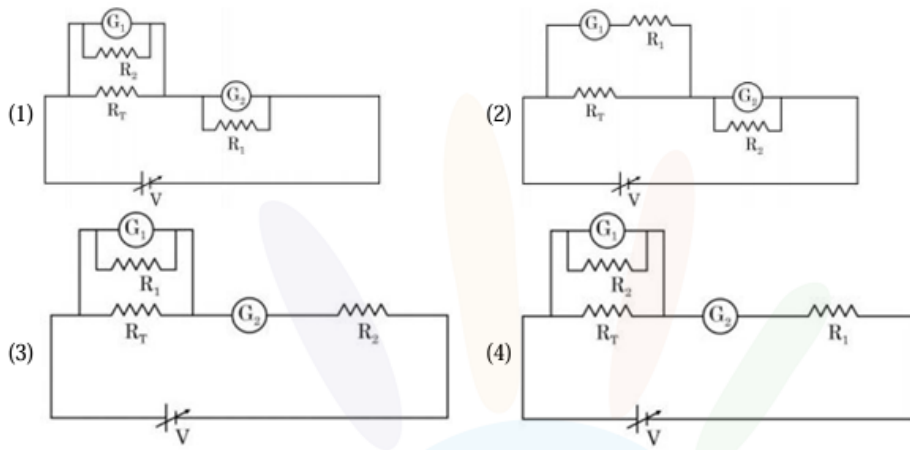

38. A body cools in 7 minutes from 60°C to 40°C . The temperature of the surroundings is 10°C . The temperature of the body after the next 7 minutes is:

- (1) 30°C
- (2) 34°C
- (3) 32°C
- (4) 28°C

39. The energy density associated with electric field E and magnetic field B of an electromagnetic wave in free space is given by ϵ_0 - permittivity of free space, μ_0 - permeability of free space:

- (1) $U_E = \frac{\epsilon_0 E^2}{2}, U_B = \frac{B^2}{2\mu_0}$
- (2) $U_E = \frac{E^2}{2\epsilon_0}, U_B = \frac{\mu_0 B^2}{2}$
- (3) $U_E = \frac{E^2}{2\epsilon_0}, U_B = \frac{B^2}{2\mu_0}$
- (4) $U_E = \epsilon_0 \frac{E^2}{2}, U_B = \mu_0 \frac{B^2}{2}$

40. The weight of a body on the surface of the earth is 100 N. The gravitational force on it when taken at a height, from the surface of earth, equal to one-fourth the radius of the earth is:

- (1) 64 N
- (2) 25 N
- (3) 100 N

(4) 50 N

41. A capacitor of capacitance 150.0 F is connected to an alternating source of emf given by $E = 36 \sin(120\pi t)$ V. The maximum value of current in the circuit is approximately equal to:

- (1) $\sqrt{2}A$
 - (2) $2\sqrt{2}A$
 - (3) $\frac{1}{\sqrt{2}}A$
 - (4) $2A$
-

42. A 2 meter long scale with least count of 0.2 cm is used to measure the locations of objects on an optical bench. While measuring the focal length of a convex lens, the object pin and the convex lens are placed at 80 cm mark and 1 m mark, respectively. The image of the object pin on the other side of lens coincides with image pin that is kept at 180 cm mark. The % error in the estimation of focal length is:

- (1) 0.51
 - (2) 1.02
 - (3) 0.85
 - (4) 1.70
-

43. Figure shows a part of an electric circuit. The potentials at points a, b, and c are 30 V, 12 V, and 2 V respectively. The current through the 20 Ω resistor will be:

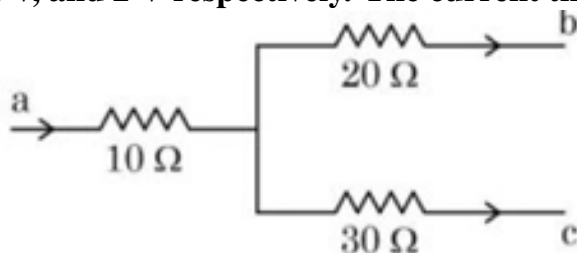

- (1) 1.0 A
- (2) 0.2 A
- (3) 0.4 A
- (4) 0.6 A

44. A small particle of mass m moves in such a way that its potential energy

$U = \frac{1}{2}m\omega^2r^2$ **where ω is constant and r is the distance of the particle from origin.**

Assuming Bohr's quantization of momentum and circular orbit, the radius of the n th orbit will be proportional to:

- (1) n
 - (2) n^2
 - (3) $\frac{1}{n}$
 - (4) \sqrt{n}
-

45. Given below are two statements: one is labelled as Assertion A and the other is labelled as Reason R

Assertion A: Diffusion current in a p-n junction is greater than the drift current in magnitude if the junction is forward biased.

Reason R: Diffusion currents in a p-n junction are from the n-side to the p-side if the junction is forward biased.

In the light of the above statements, choose the most appropriate answer from the options given below:

- (1) A is not correct but R is correct
 - (2) Both A and R are correct and R is the correct explanation of A
 - (3) A is correct but R is not correct
 - (4) Both A and R are correct but R is NOT the correct explanation of A
-

46. Choose the incorrect statement from the following :

- (1) The linear speed of a planet revolving around the sun remains constant.
 - (2) The speed of satellite in a given circular orbit remains constant.
 - (3) When a body falls towards earth, the displacement of earth towards the body is negligible.
 - (4) For a planet revolving around the sun in an elliptical orbit, the total energy of the planet remains constant.
-

47. A child of mass 5 kg is going round a merry-go-round that makes 1 rotation in 3.14

s. The radius of the merry-go-round is 2 m. The centrifugal force on the child will be :

- (1) 40 N
 - (2) 100 N
 - (3) 80 N
 - (4) 50 N
-

48. As shown in the figure, a particle is moving with constant speed π m/s. Considering its motion from A to B, the magnitude of the average velocity is :

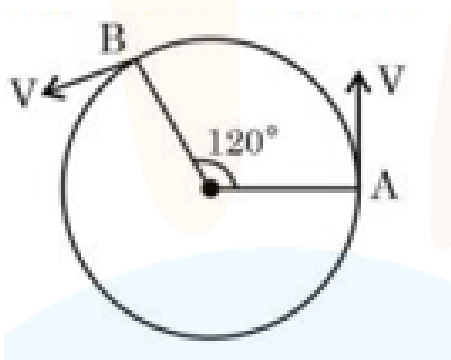

- (1) π m/s
 - (2) $2\sqrt{3}$ m/s
 - (3) $\sqrt{3}$ m/s
 - (4) $1.5\sqrt{3}$ m/s
-

49. The work functions of Aluminium and Gold are 4.1 eV and 5.1 eV respectively. The ratio of the slope of the stopping potential versus frequency plot for Gold to that of Aluminium is

- (1) 1
 - (2) 2
 - (3) 1.24
 - (4) 1.5
-

50. A particle starts with an initial velocity of 10.0 m/s along x-direction and accelerates uniformly at the rate of 2.0 m/s². The time taken by the particle to reach the velocity of 60.0 m/s is

- (1) 3s

- (2) 6s
 (3) 25s
 (4) 30s

Section-B

51. A simple pendulum with length 100 cm and bob of mass 250 g is executing S.H.M. of amplitude 10 cm. The maximum tension in the string is found to be $\frac{x}{40}$ N. The value of x is

52. Experimentally it is found that 12.8 eV energy is required to separate a hydrogen atom into a proton and an electron. So the orbital radius of the electron in a hydrogen atom is $\frac{9}{x} \times 10^{-10}$ m. The value of x is

53. A beam of light consisting of two wavelengths 7000 \AA and 5500 \AA is used to obtain interference pattern in Young's double slit experiment. The distance between the slits is 2.5 mm and the distance between the place of slits and the screen is 150 cm. The least distance from the central fringe, where the bright fringes due to both the wavelengths coincide, is $n \times 10^{-5}$ m. The value of n is

54. Two concentric circular coils with radii 1 cm and 1000 cm, and number of turns 10 and 200 respectively are placed coaxially with centers coinciding. The mutual inductance of this arrangement will be $\text{---} \times 10^8 \text{ H}$.

55. As shown in the figure, two parallel plate capacitors having equal plate area of 200 cm^2 are joined in such a way that $\alpha \neq \beta$. The equivalent capacitance of the combination is $x\epsilon_0 \text{ F}$. The value of x is

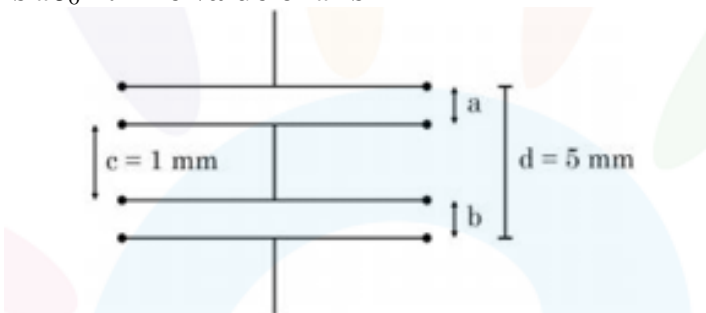

56. A proton with a kinetic energy of 2.0 eV moves into a region of uniform magnetic field of magnitude $\frac{\pi}{2} \times 10^{-3} \text{T}$. The angle between the direction of magnetic field and velocity of proton is 60° . The pitch of the helical path taken by the proton is ___ cm.

57. A body is dropped on ground from a height 'h₁' and after hitting the ground, it rebounds to a height 'h₂'. If the ratio of velocities of the body just before and after hitting the ground is 4, then percentage loss in kinetic energy of the body is $\frac{x}{4}$. The value of x is

58. A ring and a solid sphere rotating about an axis passing through their centers have the same radii of gyration. The axis of rotation is perpendicular to the plane of the ring. The ratio of radius of ring to that of sphere is $\sqrt{\frac{2}{x}}$. The value of x is

59. As shown in the figure, the voltmeter reads 2V across a 5 Ω resistor. The resistance of the voltmeter is ____ Ω.

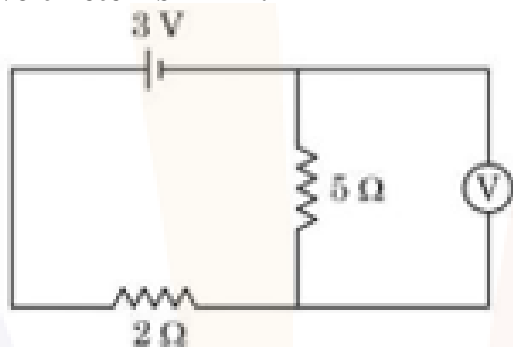

60. A metal block of mass m is suspended from a rigid support through a metal wire of diameter 14 mm. The tensile stress developed in the wire under equilibrium state is $7 \times 10^5 \text{Nm}^{-2}$. The value of mass m is ____ kg.

CHEMISTRY

Section-A

61. Match List I with List II

List I (Natural Amino acid)	List II (One Letter Code)
(A) Arginine	(I) D
(B) Aspartic acid	(II) N
(C) Asparagine	(III) A
(D) Alanine	(IV) R

Choose the correct answer from the options given below:

- (1) (A) – III, (B) – I, (C) – II (D) – IV
- (2) (A) – IV, (B) – I, (C) – II (D) – III
- (3) (A) – IV, (B) – I, (C) – III (D) – II
- (4) (A) – I, (B) – III, (C) – IV (D) – II

62. Formation of which complex, among the following, is not a confirmatory test of Pb^{2+} ions

- (1) lead sulphate
- (2) lead nitrate
- (3) lead chromate
- (4) lead iodide

63. The volume of 0.02 M aqueous HBr required to neutralize 10.0 mL of 0.01 M aqueous $\text{Ba}(\text{OH})_2$ is (Assume complete neutralization)

- (1) 5.0 mL
- (2) 10.0 mL
- (3) 2.5 mL
- (4) 7.5 mL

64. Group–13 elements react with O_2 in amorphous form to form oxides of type $M_2\text{O}_3$ (M = element). Which among the following is the most basic oxide?

- (1) Al_2O_3
- (2) Tl_2O_3
- (3) Ga_2O_3

(4) B_2O_3

65. The IUPAC name of $K_3[Co(C_2O_4)_3]$ is

- (1) Potassium tris(oxalate) cobalte(III)
 - (2) Potassium trioxalatocobalt(III)
 - (3) Potassium tris(oxalate)cobalt(III)
 - (4) Potassium trioxalatocobaltate(III)
-

66. If the radius of the first orbit of hydrogen atom is a_0 , then de Broglie's wavelength of electron in 3rd orbit is:

- (A) $\frac{\pi a_0}{6}$
 - (B) $\frac{\pi a_0}{3}$
 - (C) $6\pi a_0$
 - (D) $3\pi a_0$
-

67. The group of chemicals used as pesticide is:

- (A) Sodium chlorate, DDT, PAN
 - (B) DDT, Aldrin
 - (C) Aldrin, Sodium chlorate, Sodium arsenite
 - (D) Dieldrin, Sodium arsenite, Tetrachlorothene
-

68. From the figure of column chromatography given below, identify incorrect statements.

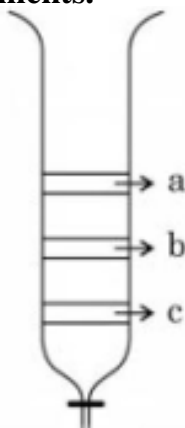

- (A) Compound 'c' is more polar than 'a' and 'b'

- (B) Compound 'a' is least polar
 (C) Compound 'b' comes out of the column before 'c' and after 'a'
 (D) Compound 'a' spends more time in the column

Choose the correct answer from the options given below:

- (1) A, B and D only
 (2) A, B and C only
 (3) B and D only
 (4) B, C and D only

69. Ion having highest hydration enthalpy among the given alkaline earth metal ions is:

- (1) Be^{2+}
 (2) Ba^{2+}
 (3) Ca^{2+}
 (4) Sr^{2+}

70. The strongest acid from the following is:

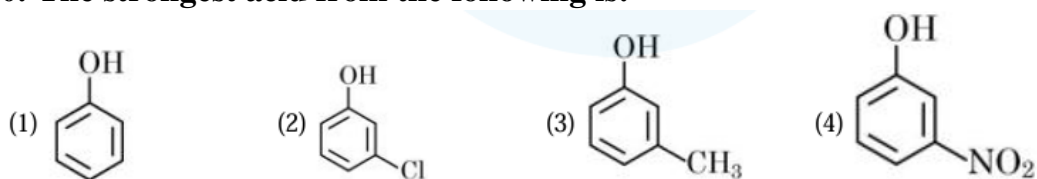

71. In the following reaction, 'B' is

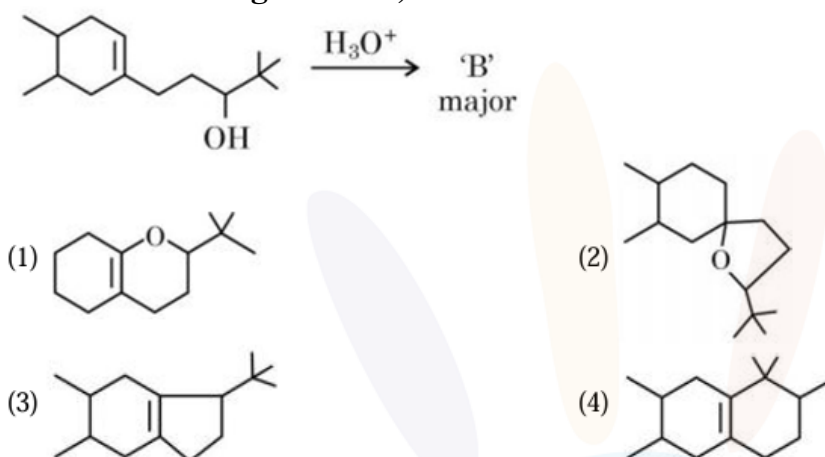

72. Structures of BeCl_2 in solid state, vapour phase and at very high temperature

respectively are:

- (1) Polymeric, Dimeric, Monomeric
 - (2) Dimeric, Polymeric, Monomeric
 - (3) Monomeric, Dimeric, Polymeric
 - (4) Polymeric, Monomeric, Dimeric
-

73. Consider the following reaction that goes from A to B in three steps as shown below:

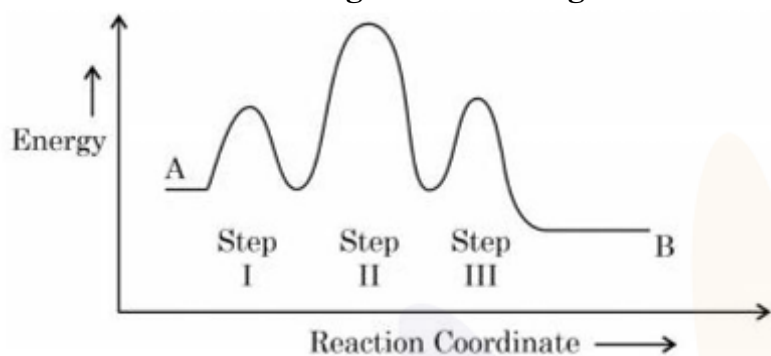

Choose the correct option

	Number of intermediates	Number of Activated complex	Rate determining step
(1)	2	3	II
(2)	3	2	II
(3)	2	3	III
(4)	2	3	I

74. The product, which is not obtained during the electrolysis of brine solution is:

- (1) HCl
 - (2) NaOH
 - (3) Cl₂
 - (4) H₂
-

75. Which one of the following elements will remain as liquid inside pure boiling water?

- (1) Li
 - (2) Ga
 - (3) Cs
 - (4) Br
-

76. Given below are two statements: one is labelled as “Assertion A” and the other is labelled as “Reason R”

Assertion A: In the complex $\text{Ni}(\text{CO})_4$ and $\text{Fe}(\text{CO})_5$, the metals have zero oxidation state.

Reason R: Low oxidation states are found when a complex has ligands capable of π -donor character in addition to the σ -bonding.

In the light of the above statement, choose the most appropriate answer from the options given below.

- (1) A is not correct but R is correct.
 - (2) A is correct but R is not correct.
 - (3) Both A and R are correct and R is the correct explanation of A.
 - (4) Both A and R are correct but R is NOT the correct explanation of A.
-

77. Given below are two statements:

Statement I: Morphine is a narcotic analgesic. It helps in relieving pain without producing sleep.

Statement II: Morphine and its derivatives are obtained from opium poppy.

In the light of the above statements, choose the correct answer from the options given below.

- (1) Statement I is true but Statement II is false.
 - (2) Statement I is false but Statement II is true.
 - (3) Both Statement I and Statement II are true.
 - (4) Both Statement I and Statement II are false.
-

78. Find out the major product from the following reaction.

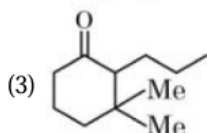
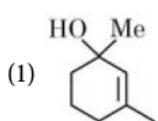
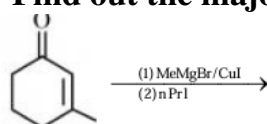

2

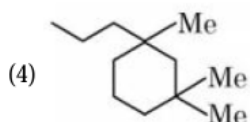
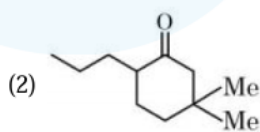

79. During the reaction of permanganate with thiosulphate, the change in oxidation of manganese occurs by value of 3. Identify which of the below medium will favour the

reaction.

- (1) aqueous neutral
 - (2) aqueous acidic
 - (3) both aqueous acidic and neutral
 - (4) both aqueous acidic and faintly alkaline
-

80. Element not present in Nessler's reagent is

- (1) K
 - (2) N
 - (3) I
 - (4) Hg
-

Section-B

81. The standard reduction potentials at 298 K for the following half cells are given below:

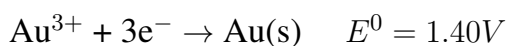
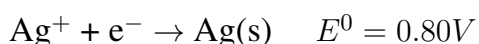
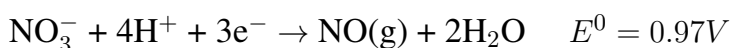

The number of metal(s) which will be oxidized by NO_3^- in aqueous solution is

82. Number of crystal system from the following where body centred unit cell can be found is ----

Cubic, tetragonal, orthorhombic, hexagonal, rhombohedral, monoclinic, triclinic

83. Among the following the number of compounds which will give positive iodoform reaction is ---

- (a) 1-Phenylbutan-2-one
- (b) 2-Methylbutan-2-ol
- (c) 3-Methylbutan-2-ol

- (d) 1-Phenylethanol
(e) 3,3-dimethylbutan-2-one
(f) 1-Phenylpropan-2-ol
-

84. Number of isomeric aromatic amines with molecular formula $C_8H_{11}N$, which can be synthesized by Gabriel Phthalimide synthesis is _____

85. Consider the following pairs of solution which will be isotonic at the same temperature. The number of pairs of solutions is/are _____

- A. 1 M aq. NaCl and 2 M aq. Urea
B. 1 M aq. $CaCl_2$ and 1.5 M aq. KCl
C. 1.5 M aq. $AlCl_3$ and 2 M aq. Na_2SO_4
D. 2.5 M aq. KCl and 1 M aq. $Al_2(SO_4)_3$
-

86. The number of colloidal systems from the following, which will have 'liquid' as the dispersion medium, is _____

Gem stones, paints, smoke, cheese, milk, hair cream, milk, insecticide sprays, froth, soap lather

87. In an ice crystal, each water molecule is hydrogen bonded to _____ neighbouring molecules.

88. Consider the following data:

Heat of combustion of $H_2(g) = -241.8 \text{ kJ mol}^{-1}$

Heat of combustion of $C(s) = -393.5 \text{ kJ mol}^{-1}$

Heat of combustion of $C_2H_5OH(l) = -1234.7 \text{ kJ mol}^{-1}$

The heat of formation of $C_2H_5OH(l)$ is (-) _____ kJ mol^{-1} (Nearest integer).

89. The equilibrium composition for the reaction $PCl_3 + Cl_2 \rightleftharpoons PCl_5$ at 298 K is given below:

l_3

$= 0.2 \text{ mol L}^{-1}$, $[Cl_2] = 0.1 \text{ mol L}^{-1}$, $[PCl_5] = 0.40 \text{ mol L}^{-1}$

If 0.2 mol of Cl_2 is added at the same temperature, the equilibrium concentrations of PCl_5 is _____ $\times 10^{-2} \text{ mol L}^{-1}$.

90. The number of species having a square planar shape from the following is_____

XeF_4 , SF_4 , SiF_4 , BF_4 , BrF_4 , $[\text{Cu}(\text{NH}_3)_4]^{2+}$, $[\text{FeCl}_4]^{2-}$, $[\text{PtCl}_4]^{2-}$
