

# JEE Main 2025 April 8th Shift 2 Physics Question Paper

Time Allowed :3 Hours	Maximum Marks :300	Total Questions :75
-----------------------	--------------------	---------------------

## General Instructions

Read the following instructions very carefully and strictly follow them:

1. Multiple choice questions (MCQs)
2. Questions with numerical values as answers.
3. There are three sections: **Mathematics, Physics, Chemistry.**
4. **Mathematics:** 25 (20+5) 10 Questions with answers as a numerical value. Out of 10 questions, 5 questions are compulsory.
5. **Physics:** 25 (20+5) 10 Questions with answers as a numerical value. Out of 10 questions, 5 questions are compulsory..
6. **Chemistry:** 25 (20+5) 10 Questions with answers as a numerical value. Out of 10 questions, 5 questions are compulsory.
7. Total: 75 Questions (25 questions each).
8. 300 Marks (100 marks for each section).
9. **MCQs:** Four marks will be awarded for each correct answer and there will be a negative marking of one mark on each wrong answer.
10. **Questions with numerical value answers:** Candidates will be given four marks for each correct answer and there will be a negative marking of 1 mark for each wrong answer.

## Physics

### Section - A

**26. Given below are two statements: one is labelled as Assertion A and the other is labelled as Reason R**

**Assertion A:** Work done in moving a test charge between two points inside a uniformly charged spherical shell is zero, no matter which path is chosen.

**Reason R:** Electrostatic potential inside a uniformly charged spherical shell is constant and is same as that on the surface of the shell.

**In the light of the above statements, choose the correct answer from the options given below**

- (1) A is false but R is true
- (2) Both A and R are true and R is the correct explanation of A

- (3) Both A and R are true but R is NOT the correct explanation of A  
 (4) A is true but R is false

27. Water falls from a height of 200 m into a pool. Calculate the rise in temperature of the water assuming no heat dissipation from the water in the pool. (Take  $g = 10 \text{ m/s}^2$ , specific heat of water =  $4200 \text{ J/(kg K)}$ )

- (1) 0.48 K  
 (2) 0.36 K  
 (3) 0.14 K  
 (4) 0.23 K

28. Figure shows a current carrying square loop ABCD of edge length is  $a$  lying in a plane. If the resistance of the ABC part is  $r$  and that of the ADC part is  $2r$ , then the magnitude of the resultant magnetic field at the center of the square loop is:

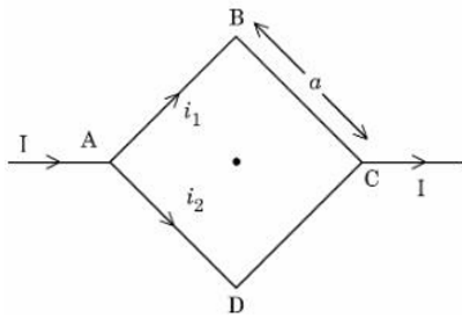

- (1)  $\frac{\sqrt{2}\mu_0 I}{3\pi a}$   
 (2)  $\frac{\mu_0 I}{2\pi a}$   
 (3)  $\frac{2\mu_0 I}{3\pi a}$   
 (4)  $\frac{3\pi\mu_0 I}{\sqrt{2}}$

29. Two metal spheres of radius  $R$  and  $3R$  have same surface charge density  $\sigma$ . If they are brought in contact and then separated, the surface charge density on smaller and bigger sphere becomes  $\sigma_1$  and  $\sigma_2$ , respectively. The ratio  $\frac{\sigma_1}{\sigma_2}$  is:

- (1) 9  
 (2)  $\frac{1}{3}$   
 (3)  $\frac{1}{9}$   
 (4) 3

30. A body of mass 2 kg moving with velocity of  $\vec{v}_{in} = 3\hat{i} + 4\hat{j} \text{ ms}^{-1}$  enters into a constant force field of 6N directed along positive z-axis. If the body remains in the field for a period of  $\frac{5}{3}$  seconds, then velocity of the body when it emerges from force field is:

- (1)  $3\hat{i} + 4\hat{j} - 5\hat{k}$
- (2)  $3\hat{i} + 4\hat{j} + 5\hat{k}$
- (3)  $3\hat{i} + 4\hat{j} + \sqrt{5}\hat{k}$
- (4)  $4\hat{i} + 3\hat{j} + 5\hat{k}$

**31. Two strings with circular cross section and made of same material are stretched to have same amount of tension. A transverse wave is then made to pass through the strings. The velocity of the wave in the first string having the radius of cross section  $R$  is  $v_1$ , and that in the other string having radius of cross section  $R/2$  is  $v_2$ .**

**Then,  $\frac{v_2}{v_1}$  is:**

- (1) 4
- (2)  $\sqrt{2}$
- (3) 8
- (4) 2

**32. The output voltage in the following circuit is (Consider ideal diode case):**

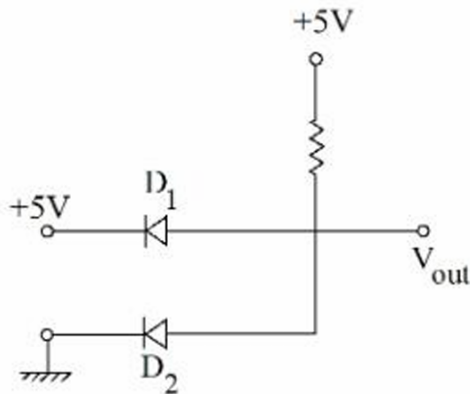

- (1)  $-5\text{ V}$
- (2)  $+5\text{ V}$
- (3)  $10\text{ V}$
- (4)  $0\text{ V}$

**33. In a Young's double slit experiment, the source is white light. One of the slits is covered by red filter and another by green filter. In this case,**

- (1) There shall be alternate interference fringes of red and green.
- (2) There shall be an interference pattern, where each fringe's pattern center is green and outer edges is red.
- (3) There shall be an interference pattern for red distinct from that for green.
- (4) There shall be no interference fringes.

34. A concave-convex lens of refractive index 1.5 and the radii of curvature of its surfaces are 30 cm and 20 cm, respectively. The concave surface is upwards and is filled with a liquid of refractive index 1. (3) The focal length of the liquid–glass combination will be:

- (1)  $\frac{800}{11}$  cm
  - (2)  $\frac{500}{11}$  cm
  - (3)  $\frac{700}{11}$  cm
  - (4)  $\frac{600}{11}$  cm
- 

35. Two balls with the same mass and initial velocity are projected at different angles in such a way that the maximum height reached by the first ball is 8 times higher than that of the second ball.  $T_1$  and  $T_2$  are the total flying times of the first and second ball, respectively, then the ratio of  $T_1$  and  $T_2$  is:

- (1) 2 : 1
  - (2)  $\sqrt{2}$  : 1
  - (3) 4 : 1
  - (4)  $2\sqrt{2}$  : 1
- 

36. An infinitely long wire has uniform linear charge density  $\lambda = 2 \text{ nC/m}$ . The net flux through a Gaussian cube of side length  $\sqrt{3}$  cm, if the wire passes through any two corners of the cube, that are maximally displaced from each other, would be  $x \text{ Nm}^2\text{C}^{-1}$ , where  $x$  is:

- (1)  $2.16\pi$
  - (2)  $0.72\pi$
  - (3)  $6.48\pi$
  - (4)  $1.44\pi$
- 

37. A convex lens of focal length 30 cm is placed in contact with a concave lens of focal length 20 cm. An object is placed at 20 cm to the left of this lens system. The distance of the image from the lens in cm is \_\_\_\_ .

- (1)  $\frac{60}{7}$  cm
  - (2) 30 cm
  - (3) 15 cm
  - (4) 45 cm
- 

38. A block of mass 2 kg is attached to one end of a massless spring whose other end is fixed at a wall. The spring-mass system moves on a frictionless horizontal table. The spring's natural length is 2 m and spring constant is 200 N/m. The

block is pushed such that the length of the spring becomes 1 m and then released.

At distance  $x$  m ( $x \leq 2$ ) from the wall, the speed of the block will be:

- (1)  $10 [1 - (2 - x)^2]$  m/s
  - (2)  $10 [1 - (2 - x)]^{3/2}$  m/s
  - (3)  $10 [1 - (2 - x)^2]^{1/2}$  m/s
  - (4)  $10 [1 - (2 - x)^2]^2$  m/s
- 

39. A quantity  $Q$  is formulated as  $Q = X^{-2}Y^{3/2}Z^{-2/5}$ .  $X$ ,  $Y$ , and  $Z$  are independent parameters which have fractional errors of 0.1, 0.2, and 0.5, respectively in measurement. The maximum fractional error of  $Q$  is:

- (1) 0.7
  - (2) 0.1
  - (3) 0.8
  - (4) 0.6
- 

40. The amplitude and phase of a wave that is formed by the superposition of two harmonic travelling waves,  $y_1(x, t) = 4 \sin(kx - \omega t)$  and  $y_2(x, t) = 2 \sin(kx - \omega t + \frac{2\pi}{3})$ , are: (Take the angular frequency of initial waves same as  $\omega$ )

- (1)  $[\sqrt{3}, \frac{\pi}{6}]$
  - (2)  $[6, \frac{\pi}{3}]$
  - (3)  $[2\sqrt{3}, \frac{\pi}{6}]$
  - (4)  $[6, \frac{2\pi}{3}]$
- 

41. For a nucleus of mass number  $A$  and radius  $R$ , the mass density of the nucleus can be represented as:

- (1)  $\frac{2}{3}A$
  - (2)  $\frac{1}{3}A$
  - (3)  $A^3$
  - (4) Independent of  $A$
- 

42. A monoatomic gas having  $\gamma = \frac{5}{3}$  is stored in a thermally insulated container and the gas is suddenly compressed to  $(\frac{1}{8})^{\text{th}}$  of its initial volume. The ratio of final pressure and initial pressure is:

- (1) 28
  - (2) 32
  - (3) 40
  - (4) 16
-

43. Electric charge is transferred to an irregular metallic disk as shown in the figure. If  $\sigma_1$ ,  $\sigma_2$ ,  $\sigma_3$ , and  $\sigma_4$  are charge densities at given points, then choose the correct answer from the options given below:

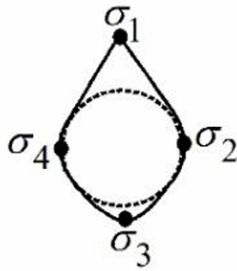

- A.  $\sigma_1 > \sigma_3$  ;  $\sigma_2 = \sigma_4$
- B.  $\sigma_1 > \sigma_2$  ;  $\sigma_3 > \sigma_4$
- C.  $\sigma_1 > \sigma_3 > \sigma_2 = \sigma_4$
- D.  $\sigma_1 < \sigma_3 < \sigma_2 = \sigma_4$
- E.  $\sigma_1 = \sigma_2 = \sigma_3 = \sigma_4$

- (1) D and E Only
- (2) A and C Only
- (3) A, B, and C Only
- (4) B and C Only

44. A 3 m long wire of radius 3 mm shows an extension of 0.1 mm when loaded vertically by a mass of 50 kg in an experiment to determine Young's modulus. The value of Young's modulus of the wire as per this experiment is  $P \times 10^{11} \text{ N/m}^2$ , where the value of  $P$  is: (Take  $g = 3\pi \text{ m/s}^2$ )

- (1) 25
- (2) 10
- (3) 2.5
- (4) 5

45. A rod of linear mass density  $\lambda$  and length  $L$  is bent to form a ring of radius  $R$ . Moment of inertia of the ring about any of its diameter is:

- (1)  $\frac{\lambda L^3}{8\pi^2}$
- (2)  $\frac{\lambda L^3}{4\pi^2}$
- (3)  $\frac{\lambda L^3}{16\pi^2}$
- (4)  $\frac{\lambda L^3}{12}$

## Section - B

46. A cube having a side of 10 cm with unknown mass and 200 gm mass were hung at two ends of an uniform rigid rod of 27 cm long. The rod along with masses was placed on a wedge keeping the distance between wedge point and 200 gm weight as 25 cm. Initially the masses were not at balance. A beaker is placed beneath the unknown mass and water is added slowly to it. At given point the masses were in balance and half volume of the unknown mass was inside the water. (Take the density of the unknown mass is more than that of the water, the mass did not absorb water and water density is  $1 \text{ gm/cm}^3$ .) The unknown mass is \_\_\_\_\_ kg.

---

47. A thin solid disk of 1 kg is rotating along its diameter axis at the speed of 1800 rpm. By applying an external torque of  $25\pi \text{ Nm}$  for 40s, the speed increases to 2100 rpm. The diameter of the disk is \_\_\_\_\_ m.

---

48. An electron is released from rest near an infinite non-conducting sheet of uniform charge density  $\sigma$ . The rate of change of de-Broglie wavelength associated with the electron varies inversely as  $n^{\text{th}}$  power of time. The numerical value of  $n$  is \_\_\_\_\_.

---

49. A sample of a liquid is kept at 1 atm. It is compressed to 5 atm which leads to change of volume of  $0.8 \text{ cm}^3$ . If the bulk modulus of the liquid is 2 GPa, the initial volume of the liquid was \_\_\_\_\_ litre. (Take  $1 \text{ atm} = 10^5 \text{ Pa}$ )

---

50. Space between the plates of a parallel plate capacitor of plate area  $4 \text{ cm}^2$  and separation of  $d = 1.77 \text{ mm}$ , is filled with uniform dielectric materials with dielectric constants (3 and 5) as shown in figure. Another capacitor of capacitance  $7.5 \text{ pF}$  is connected in parallel with it. The effective capacitance of this combination is \_\_\_\_\_ pF.

---