

NEET 2024 S2 Question Paper

Time Allowed :3 Hours 20 Minutes	Maximum Marks :720	Total Questions :200
---	---------------------------	-----------------------------

General Instructions

Read the following instructions very carefully and strictly follow them:

- (A) The NEET Exam will be structured with a total of 720 marks.
- (B) The total duration of Exam is 3 Hours 20 Minutes. (C) It will be divided in 3 sections.

1. A wheel of a bullock cart is rolling on a level road as shown in the figure below. If its linear speed is v in the direction shown, which one of the following options is correct (P and Q are the highest and lowest points on the wheel, respectively)?

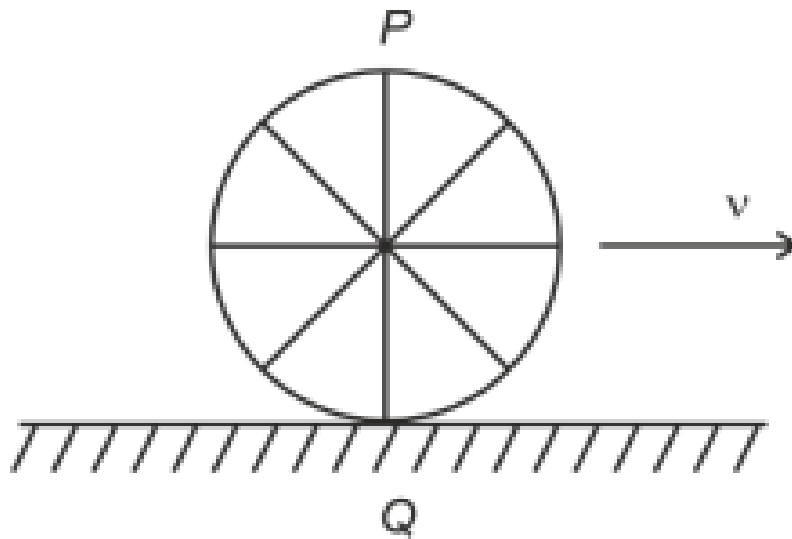

- Options:** (1) Point P has zero speed
 (2) Point P moves slower than point Q
 (3) Point P moves faster than point Q
 (4) Both the points P and Q move with equal speed

2. The output (Y) of the given logic gate is similar to the output of an/a:

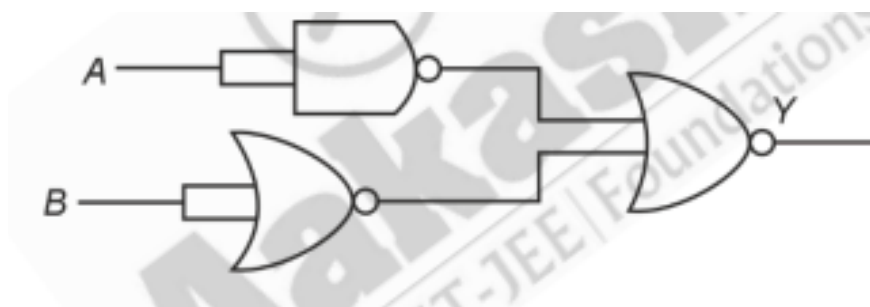

- Options:** (1) AND gate
 (2) NAND gate
 (3) NOR gate
 (4) OR gate

3. The graph which shows the variation of $(\frac{1}{\lambda^2})$ and its kinetic energy, E is (where λ is de Broglie wavelength of a free particle):

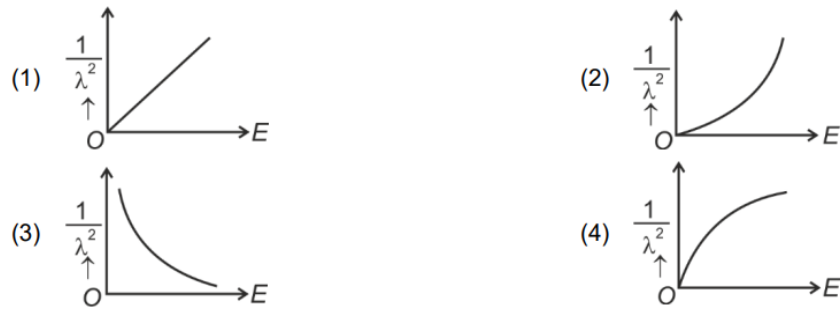

- Options:** (1) $(\frac{1}{\lambda^2})$ increases linearly with E
 (2) $(\frac{1}{\lambda^2})$ increases exponentially with E
 (3) $(\frac{1}{\lambda^2})$ decreases with E
 (4) $(\frac{1}{\lambda^2})$ follows a hyperbolic curve with E

4. In the above diagram, a strong bar magnet is moving towards solenoid-2 from solenoid-1. The direction of induced current in solenoid-1 and that in solenoid-2, respectively, are through the directions:

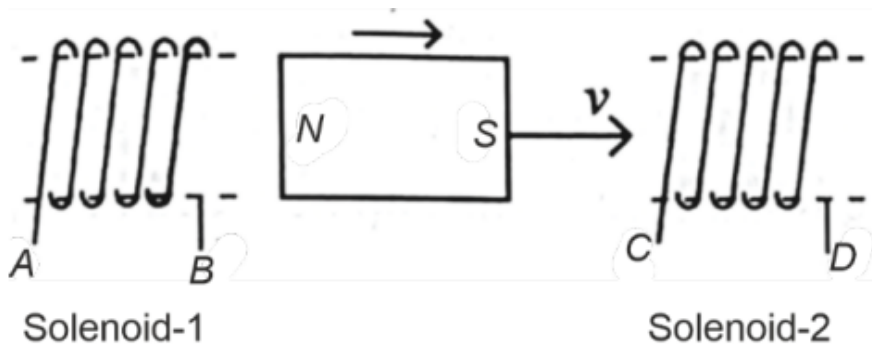

- Options:** (1) BA and DC
 (2) AB and DC
 (3) BA and CD
 (4) AB and CD

Solution: By Lenz's law, the induced current in solenoid-1 will oppose the approaching bar magnet's motion, creating a north pole at A and a south pole at B , resulting in a current

direction from A to B (AB). Similarly, solenoid-2 will develop a north pole at D and a south pole at C due to the influence of the bar magnet, resulting in a current direction from D to C (DC).

5. A thermodynamic system is taken through the cycle $abcd$. The work done by the gas along the path bc is:

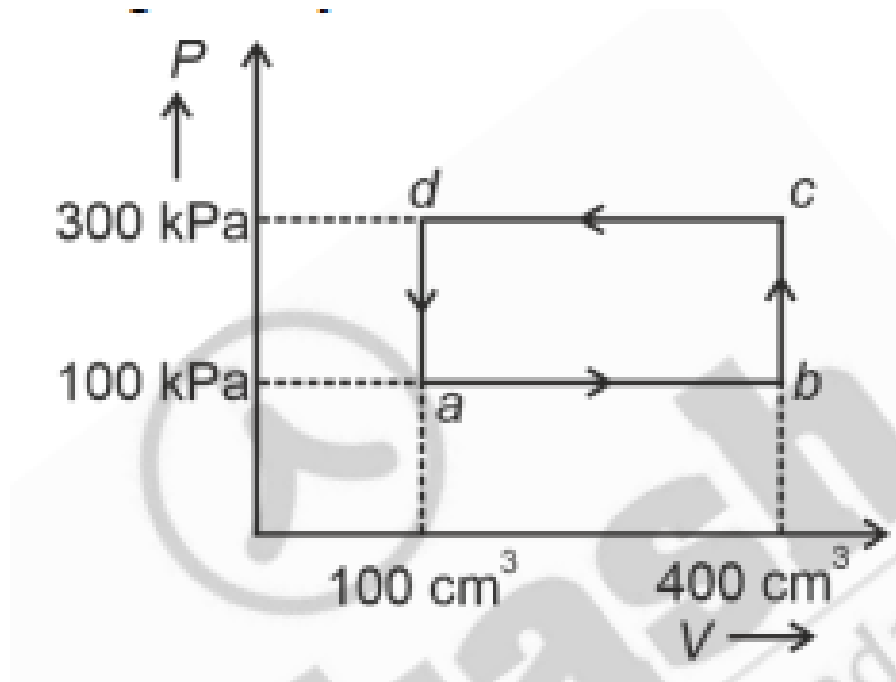

Options: (1) -60 J

(2) Zero

(3) 30 J

(4) -90 J

6. Two bodies A and B of same mass undergo completely inelastic one-dimensional collision. The body A moves with velocity v_1 while body B is at rest before collision. The velocity of the system after collision is v_2 . The ratio $v_1 : v_2$ is:

Options: (1) $1 : 4$

(2) $1 : 2$

(3) $2 : 1$

(4) $4 : 1$

7. At any instant of time t , the displacement of any particle is given by $2t - 1$ (SI unit) under the influence of force of 5 N. The value of instantaneous power is (in SI unit):

Options: (1) 6

(2) 10

(3) 5

(4) 7

8. A thin spherical shell is charged by some source. The potential difference between the two points C and P (in V) shown in the figure is:

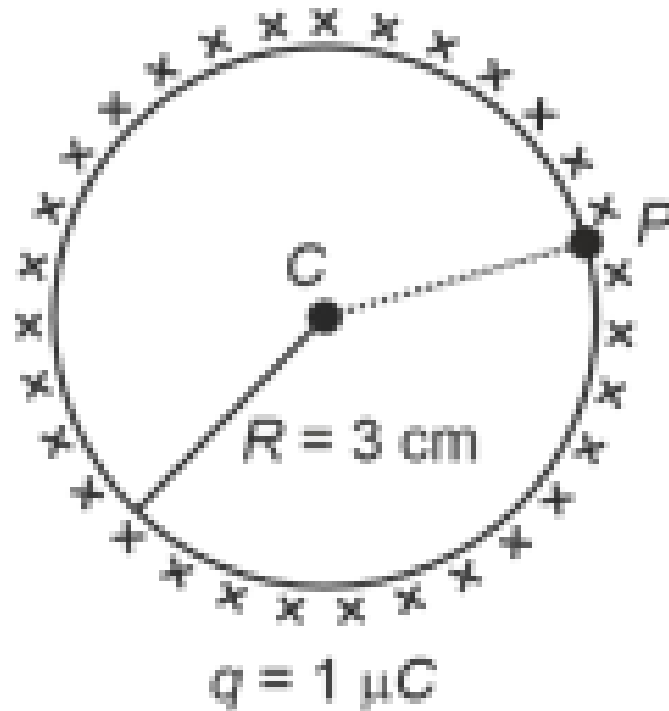

Options: (1) Zero

(2) 3×10^5

(3) 1×10^5

(4) 0.5×10^5

9. A tightly wound 100 turns coil of radius 10 cm carries a current of 7 A. The magnitude of the magnetic field at the centre of the coil is (Take permeability of free space as $4\pi \times 10^{-7}$ SI units):

- Options:** (1) 44 T
(2) 4 T
(3) 44×10^{-3} T
(4) 4 mT
-

10. If the monochromatic source in Young's double slit experiment is replaced by white light, then:

- Options:** (1) All bright fringes will be of equal width
(2) Interference pattern will disappear
(3) There will be a central dark fringe surrounded by a few coloured fringes
(4) There will be a central bright fringe surrounded by a few coloured fringes
-

11. The quantities which have the same dimensions as those of solid angle are:

- Options:** (1) angular speed and stress
(2) strain and angle
(3) stress and angle
(4) strain and arc
-

12. The mass of a planet is $\frac{1}{10}$ that of the earth and its diameter is half that of the earth. The acceleration due to gravity on that planet is:

- Options:** (1) 3.92 m/s^2
(2) 19.6 m/s^2
(3) 9.8 m/s^2
(4) 4.9 m/s^2
-

13. A horizontal force of 10 N is applied to a block A as shown in figure. The mass of blocks A and B are 2 kg and 3 kg respectively. The blocks slide over a frictionless surface. The force exerted by block A on block B is:

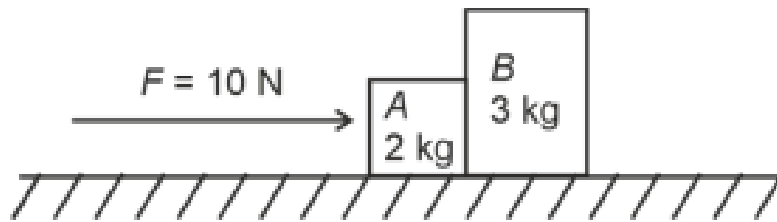

Options: (1) 10 N

(2) Zero

(3) 4 N

(4) 6 N

14. In a uniform magnetic field of 0.049 T, a magnetic needle performs 20 complete oscillations in 5 seconds as shown. The moment of inertia of the needle is $9.8 \times 10^{-6} \text{ kg m}^2$. If the magnitude of magnetic moment of the needle is $x \times 10^{-5} \text{ Am}^2$, then the value of x is:

Options: (1) $1280\pi^2$

(2) $5\pi^2$

(3) $128\pi^2$

(4) $50\pi^2$

15. The terminal voltage of the battery, whose emf is 10 V and internal resistance 1 Ω , when connected through an external resistance of 4 Ω as shown in the figure is:

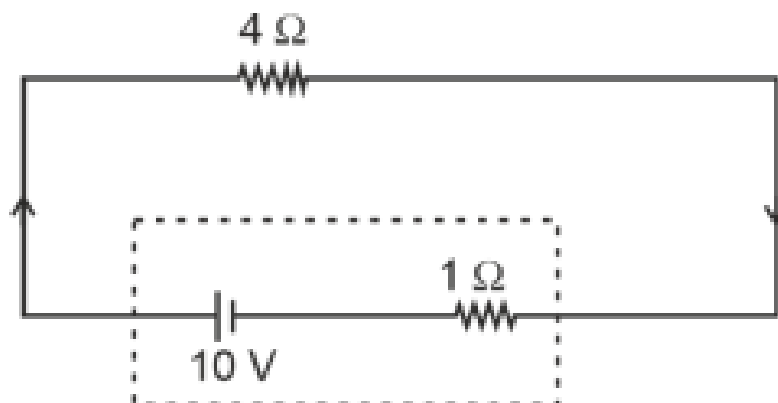

Options: (1) 10 V

(2) 4 V

(3) 6 V

(4) 8 V

16. If $x = 5 \sin \left(\pi t + \frac{\pi}{3} \right)$ m represents the motion of a particle executing simple harmonic motion, the amplitude and time period of motion, respectively, are:

Options: (1) 5 m, 1 s

(2) 5 cm, 2 s

(3) 5 m, 2 s

(4) 5 cm, 1 s

17. Match List-I with List-II:

List-I (Material) A. Diamagnetic

B. Ferromagnetic

C. Paramagnetic

D. Non-magnetic

List-II (Susceptibility χ) I. $\chi = 0$

II. $0 < \chi < 1$

III. $\chi \gg 1$

IV. $\chi > 0$ (a small positive number)

Choose the correct answer from the options given below:

Options: (1) A-IV, B-III, C-II, D-I

(2) A-II, B-III, C-I, D-I

(3) A-II, B-I, C-III, D-IV

(4) A-III, B-II, C-I, D-IV

18. Consider the following statements A and B and identify the correct answer:

A. For a solar-cell, the I-V characteristics lies in the IV quadrant of the given graph. B. In a reverse biased pn junction diode, the current measured in μA , is due to majority charge carriers.

Options: (1) Both A and B are incorrect

(2) A is correct but B is incorrect

(3) A is incorrect but B is correct

(4) Both A and B are correct

19. Given below are two statements:

Statement I: Atoms are electrically neutral as they contain equal number of positive and negative charges. Statement II: Atoms of each element are stable and emit their characteristic spectrum.

In the light of the above statements, choose the most appropriate answer from the options given below:

Options: (1) Statement I is incorrect but Statement II is correct

(2) Both Statement I and Statement II are correct

(3) Both Statement I and Statement II are incorrect

(4) Statement I is correct but Statement II is incorrect

20. In a vernier calipers, $(N + 1)$ divisions of vernier scale coincide with N divisions of main scale. If 1 MSD represents 0.1 mm, the vernier constant (in cm) is:

Options: (1) $10(N + 1)$

(2) $\frac{1}{10N}$

(3) $\frac{1}{100(N+1)}$

(4) $100N$

21. In an ideal transformer, the turns ratio is $N_p : N_s = 1 : 2$. The ratio $V_s : V_p$ is equal to (the symbols carry their usual meaning):

Options: (1) 1 : 4

(2) 2 : 1

(3) 1 : 2

(4) 4 : 1

22. An unpolarised light beam strikes a glass surface at Brewster's angle. Then:

Options: (1) The reflected light will be completely polarised but the refracted light will be partially polarised.

(2) The reflected light will be partially polarised.

(3) The refracted light will be completely polarised.

(4) Both the reflected and refracted light will be completely polarised.

23. Match List-I with List-II:

List I (Spectral Lines of Hydrogen for transitions from) A. $n_2 = 3$ to $n_1 = 2$

B. $n_2 = 4$ to $n_1 = 2$

C. $n_2 = 5$ to $n_1 = 2$

D. $n_2 = 6$ to $n_1 = 2$

List II (Wavelengths (nm)) I. 410.2

II. 434.1

III. 656.3

IV. 486.1

Choose the correct answer from the options given below:

Options: (1) A-I, B-II, C-III, D-IV

(2) A-II, B-I, C-IV, D-III

(3) A-III, B-IV, C-II, D-I

(4) A-IV, B-III, C-II, D-I

24. A wire of length l and resistance 100Ω is divided into 10 equal parts. The first 5 parts are connected in series while the next 5 parts are connected in parallel. The two combinations are again connected in series. The resistance of this final combination is:

- Options:** (1) 60Ω
(2) 26Ω
(3) 52Ω
(4) 55Ω
-

25. A light ray enters through a right-angled prism at point P with the angle of incidence 30° as shown. It travels through the prism parallel to its base BC and emerges along the face AC. The refractive index of the prism is:

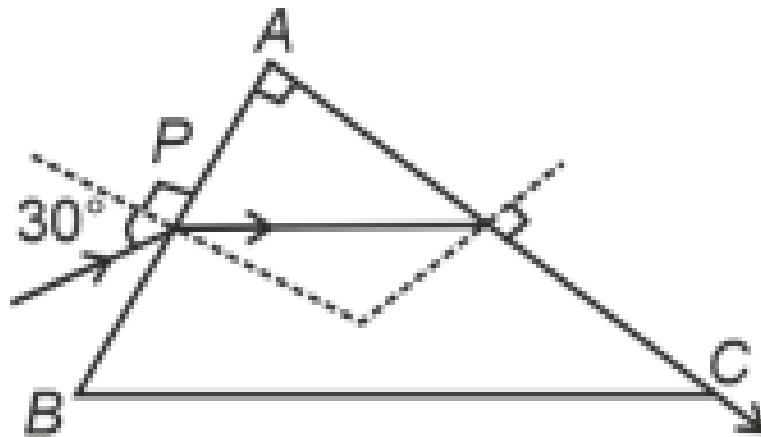

- Options:** (1) $\frac{\sqrt{3}}{2}$
(2) $\frac{\sqrt{5}}{4}$
(3) $\frac{\sqrt{5}}{2}$
(4) $\frac{\sqrt{3}}{4}$
-

26. A particle moving with uniform speed in a circular path maintains:

- Options:** (1) Varying velocity and varying acceleration
(2) Constant velocity
(3) Constant acceleration
(4) Constant velocity but varying acceleration

27. In the nuclear emission stated above, the mass number and atomic number of the product Q respectively, are:

Options: (1) 286, 81

(2) 280, 81

(3) 286, 80

(4) 288, 82

28. Given below are two statements: one is labelled as Assertion A and the other is labelled as Reason R.

Assertion A: The potential (V) at any axial point, at 2 m distance (r) from the centre of the dipole of dipole moment vector \vec{P} of magnitude, 4×10^{-6} C m, is 9×10^3 V.

Reason R: $V = \pm \frac{2P}{4\pi\epsilon_0 r^2}$, where r is the distance of any axial point, situated at 2 m from the centre of the dipole.

In the light of the above statements, choose the correct answer from the options given below:

Options: (1) A is false but R is true

(2) Both A and R are true and R is the correct explanation of A.

(3) Both A and R are true and R is NOT the correct explanation of A.

(4) A is true but R is false.

29. In the following circuit, the equivalent capacitance between terminal A and terminal B is:

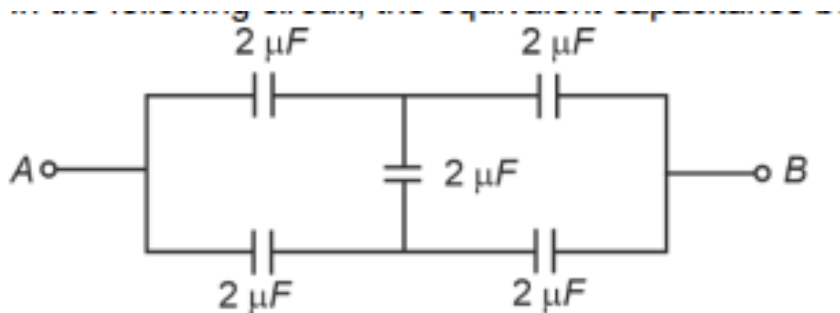

Options: (1) $4 \mu\text{F}$

- (2) $2 \mu\text{F}$
 - (3) $1 \mu\text{F}$
 - (4) $0.5 \mu\text{F}$
-

30. If c is the velocity of light in free space, the correct statements about photon among the following are:

A. The energy of a photon is $E = h\nu$. B. The velocity of a photon is c . C. The momentum of a photon, $p = \frac{h\nu}{c}$. D. In a photon-electron collision, both total energy and total momentum are conserved. E. Photon possesses positive charge.

Options: (1) A, B, D and E only

- (2) A and B only
 - (3) A, B, C and D only
 - (4) A, C and D only
-

31. A bob is whirled in a horizontal plane by means of a string with an initial speed of ω rpm. The tension in the string is T . If speed becomes 2ω while keeping the same radius, the tension in the string becomes:

Options: (1) $\sqrt{2}T$

- (2) T
 - (3) $4T$
 - (4) $T/4$
-

32. A logic circuit provides the output Y as per the following truth table:

A	B	Y
0	0	1
0	1	0
1	0	1
1	1	0

The expression for the output Y is:

Options: (1) B

(2) $AB + A$

(3) $AB + A$

(4) B

33. The maximum elongation of a steel wire of 1 m length if the elastic limit of steel and its Young's modulus, respectively, are $8 \times 10^8 \text{ N m}^{-2}$ and $2 \times 10^{11} \text{ N m}^{-2}$, is:

Options: (1) 8 mm

(2) 4 mm

(3) 0.4 mm

(4) 40 mm

34. A thin flat circular disc of radius 4.5 cm is placed gently over the surface of water. If surface tension is 0.07 N m^{-1} , then the excess force required to take it away from the surface is:

Options: (1) 99 N

(2) 19.8 mN

(3) 198 N

(4) 1.98 mN

35. The moment of inertia of a thin rod about an axis passing through its mid-point and perpendicular to the rod is 2400 g cm^2 . The length of the 400 g rod is nearly:

Options: (1) 72.0 cm

(2) 8.5 cm

(3) 17.5 cm

(4) 20.7 cm

36. The minimum energy required to launch a satellite of mass m from the surface of earth

of mass M and radius R in a circular orbit at an altitude of $2R$ from the surface of the earth is:

Options: (1) $\frac{GmM}{3R}$

(2) $\frac{5GmM}{6R}$

(3) $\frac{2GmM}{3R}$

(4) $\frac{GmM}{2R}$

37. A force defined by $F = \alpha\beta + \beta t$ acts on a particle at a given time t . The factor which is dimensionless, if α and β are constants, is:

Options: (1) $\frac{\alpha\beta}{t}$

(2) $\frac{\beta t}{\alpha}$

(3) $\frac{\alpha t}{\beta}$

(4) $\alpha\beta t$

38. A sheet is placed on a horizontal surface in front of a strong magnetic pole. A force is needed to: A. hold the sheet there if it is magnetic. B. hold the sheet there if it is non-magnetic. C. move the sheet away from the pole with uniform velocity if it is conducting. D. move the sheet away from the pole with uniform velocity if it is both, non-conducting and non-polar.

Choose the correct statement(s) from the options given below:

Options: (1) C only

(2) B and C only

(3) A and C only

(4) A, C and D only

39. A $10 \mu\text{F}$ capacitor is connected to a 210 V , 50 Hz source as shown in the figure. The peak current in the circuit is nearly (take $\pi = 3.14$):

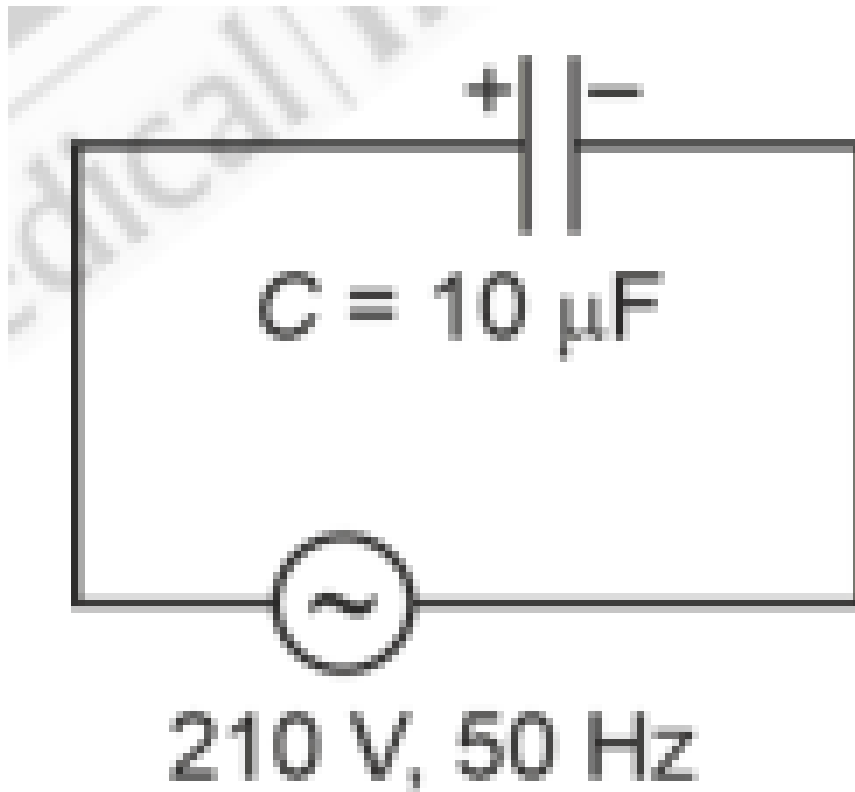

Options: (1) 0.35 A

(2) 0.58 A

(3) 0.93 A

(4) 1.20 A

40. A small telescope has an objective of focal length 140 cm and an eye piece of focal length 5.0 cm. The magnifying power of the telescope for viewing a distant object is:

Options: (1) 32

(2) 34

(3) 28

(4) 17

41. A metallic bar of Young's modulus $0.5 \times 10^{11} \text{ N m}^{-2}$ and coefficient of linear thermal expansion $10^{-5} \text{ }^\circ\text{C}^{-1}$, length 1 m and area of cross-section 10^{-3} m^2 is heated from 0°C to 100°C without expansion or bending. The compressive force developed in it is:

Options: (1) $2 \times 10^3 \text{ N}$

- (2) $5 \times 10^3 \text{ N}$
- (3) $50 \times 10^3 \text{ N}$
- (4) $100 \times 10^3 \text{ N}$

42. If the plates of a parallel plate capacitor connected to a battery are moved close to each other, then:

- Options:** A. the charge stored in it, increases.
B. the energy stored in it, decreases.
C. its capacitance increases.
D. the ratio of charge to its potential remains the same.
E. the product of charge and voltage increases.

Choose the most appropriate answer from the options given below:

- Options:** (1) A, B and C only
(2) A, B and E only
(3) A, C and E only
(4) B, D and E only

43. The velocity (v) – time (t) plot of the motion of a body is shown below:

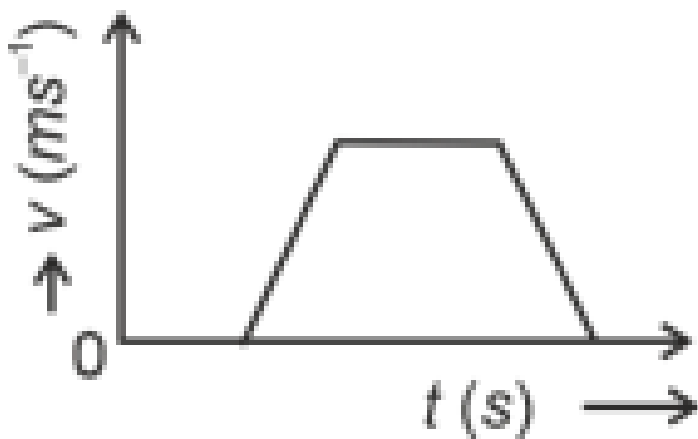

The acceleration (a) – time (t) graph that best suits this motion is:

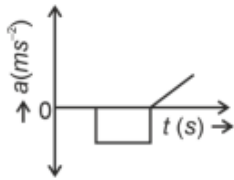

Options: (1)

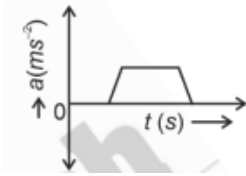

(2)

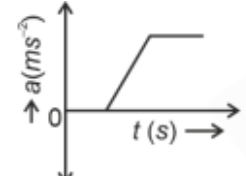

(3)

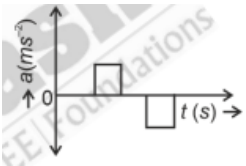

(4)

44. Two heaters A and B have power ratings of 1 kW and 2 kW, respectively. Those two are first connected in series and then in parallel to a fixed power source. The ratio of power outputs for these two cases is:

Options: (1) 2 : 3

(2) 1 : 1

(3) 2 : 9

(4) 1 : 2

45. The property which is not of an electromagnetic wave travelling in free space is that:

Options:

(1) They originate from charges moving with uniform speed

(2) They are transverse in nature

(3) The energy density in electric field is equal to energy density in magnetic field

(4) They travel with a speed equal to $\frac{1}{\sqrt{\mu_0\epsilon_0}}$

46. A parallel plate capacitor is charged by connecting it to a battery through a resistor. If I is the current in the circuit, then in the gap between the plates:

Options:

- (1) Displacement current of magnitude greater than I flows but can be in any direction
 - (2) There is no current
 - (3) Displacement current of magnitude equal to I flows in the same direction as I
 - (4) Displacement current of magnitude equal to I flows in a direction opposite to that of I
-

47. If the mass of the bob in a simple pendulum is increased to thrice its original mass and its length is made half its original length, then the new time period of oscillation is $\frac{1}{\sqrt{2}}$ times its original time period. Then the value of x is:

Options:

- (1) 4
 - (2) $\sqrt{3}$
 - (3) $\sqrt{2}$
 - (4) $2\sqrt{3}$
-

48. The following graph represents the $T - V$ curves of an ideal gas (where T is the temperature and V the volume) at three pressures P_1 , P_2 and P_3 compared with those of Charles's law represented as dotted lines.

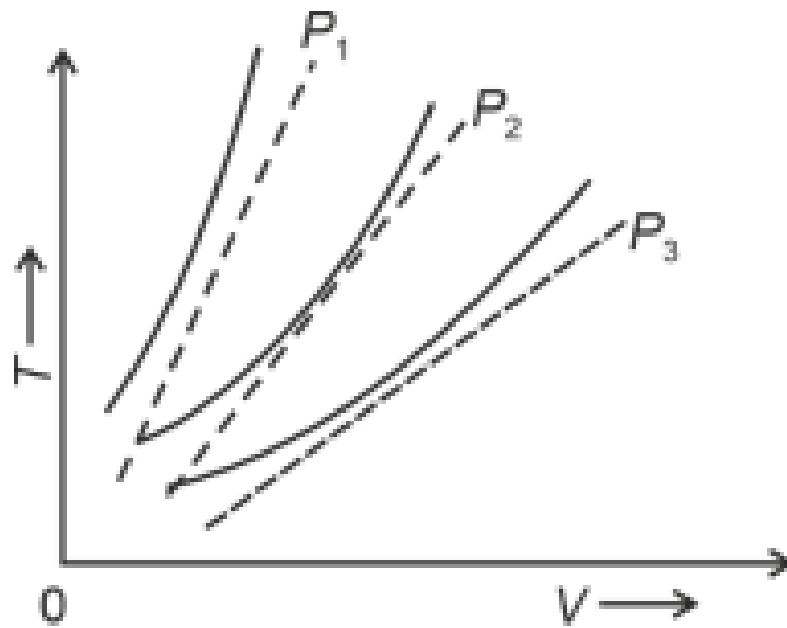

Then the correct relation is:

Options:

- (1) $P_1 > P_2 > P_3$
- (2) $P_3 > P_2 > P_1$
- (3) $P_1 > P_3 > P_2$
- (4) $P_2 > P_1 > P_3$

49. Choose the correct circuit which can achieve the bridge balance.

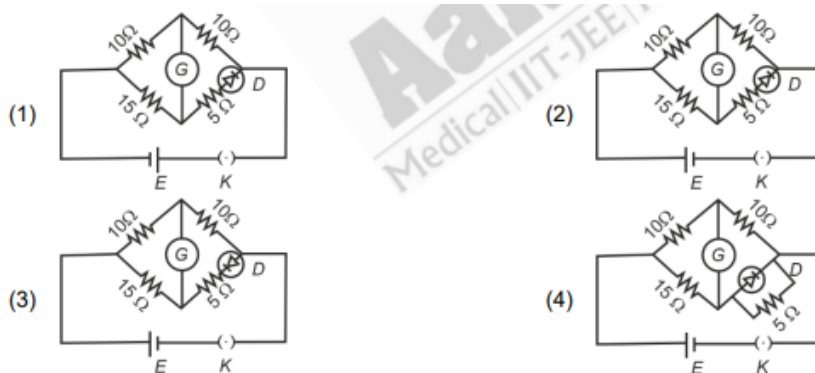

Options:

- (1) Figure (1)
- (2) Figure (2)

(3) Figure (3)

(4) Figure (4)

50. An iron bar of length L has magnetic moment M . It is bent at the middle of its length such that the two arms make an angle of 60° with each other. The magnetic moment of this new magnet is:

Options:

(1) $\frac{M}{\sqrt{3}}$

(2) M

(3) $\frac{M}{2}$

(4) $2M$

51. For the reaction $2A \rightleftharpoons B + C$, $K_c = 4 \times 10^{-3}$. At a given time, the composition of the reaction mixture is:

$$[A] = [B] = [C] = 2 \times 10^{-3} \text{ M}$$

Then, which of the following is correct?

Options: (1) Reaction has gone to completion in forward direction.

(2) Reaction is at equilibrium.

(3) Reaction has a tendency to go in forward direction.

(4) Reaction has a tendency to go in backward direction.

52. The highest number of helium atoms is in:

Options: (1) 2.271098 L of helium at STP

(2) 4 mol of helium

(3) 4 u of helium

(4) 5 g of helium

53. A compound with a molecular formula of C_6H_{14} has two tertiary carbons. Its IUPAC

name is:

Options: (1) 2,2-dimethylbutane

(2) n-hexane

(3) 2-methylpentane

(4) 2,3-dimethylbutane

54. Match List I with List II.

List I (Conversion)	List II (Number of Faraday required)
A. 1 mol of H_2O to O_2	I. 3F
B. 1 mol of MnO_4^- to Mn^{2+}	II. 2F
C. 1.5 mol of Ca from molten CaCl_2	III. 1F
D. 1 mol of FeO to Fe_2O_3	V. 5F

Choose the correct answer from the options given below:

(1) A-I, B-V, C-II, D-I

(2) A-III, B-IV, C-I, D-II

(3) A-III, B-IV, C-IV, D-I

(4) A-II, B-III, C-I, D-IV

55. Arrange the following elements in increasing order of electronegativity: N, O, F, C, Si.

Choose the correct answer from the options given below:

(1) F ; O ; N ; C ; Si

(2) Si ; C ; O ; N ; F

(3) Si ; C ; O ; N ; F

(4) O ; F ; N ; C ; Si

56. Which plot of $\ln k$ vs $\frac{1}{T}$ is consistent with Arrhenius equation?

Choose the correct answer from the options given below:

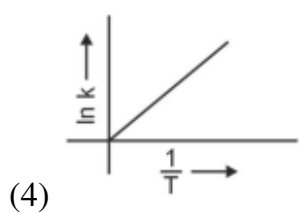
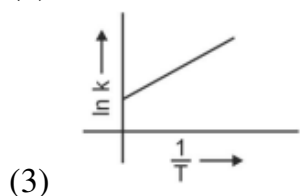
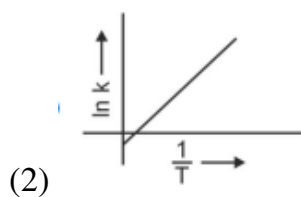
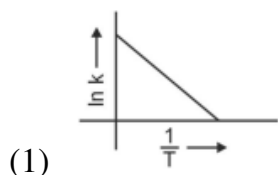

57. In which of the following equilibria, K_p and K_c are NOT equal?

Choose the correct answer from the options given below:

- (1) $2\text{BrCl}(g) \rightleftharpoons \text{Br}_2(g) + \text{Cl}_2(g)$
- (2) $\text{PCl}_3(g) \rightleftharpoons \text{PCl}_5(g) + \text{Cl}_2(g)$
- (3) $\text{H}_2(g) + \text{I}_2(g) \rightleftharpoons 2\text{HI}(g)$
- (4) $\text{CO}(g) + \text{H}_2\text{O}(g) \rightleftharpoons \text{CO}_2(g) + \text{H}_2(g)$

58. The most stable carbocation among the following is:

Choose the correct answer from the options given below:

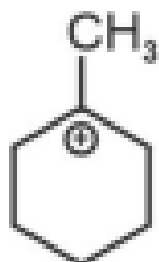

(1)

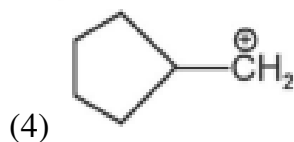
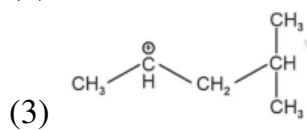
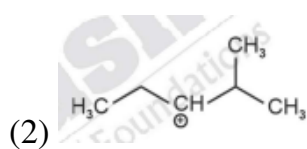

59. Activation energy of any chemical reaction can be calculated if one knows the value of:

Choose the correct answer from the options given below:

- (1) rate constant at two different temperatures
 - (2) rate constant at standard temperature
 - (3) probability of collision
 - (4) orientation of reactant molecules during collision
-

60. Given below are two statements:

Statement I: The boiling point of hydrides of Group 16 elements follow the order $H_2O > H_2Te > H_2Se > H_2S$.

Statement II: On the basis of molecular mass, H_2O is expected to have lower boiling point than the other members of the group but due to the presence of extensive H-bonding in H_2O , it has higher boiling point.

In the light of the above statements, choose the correct answer from the options given below:

- (1) Statement I is false but Statement II is true
 - (2) Both Statement I and Statement II are true
 - (3) Both Statement I and Statement II are false
 - (4) Statement I is true but Statement II is false
-

61. Which one of the following alcohols reacts instantaneously with Lucas reagent?

Choose the correct answer from the options given below:

- (1) $\text{CH}_3\text{CH}_2\text{OH}$
 - (2) $\text{CH}_3\text{CH}_2\text{CH}_2\text{OH}$
 - (3) $\text{CH}_3\text{CH}_2\text{CH}(\text{OH})_2$
 - (4) $\text{CH}_3\text{CH}_2\text{CH}_2\text{OH}$
-

62. Given below are two statements:

Statement I: Aniline does not undergo Friedel-Crafts alkylation reaction.

Statement II: Aniline cannot be prepared through Gabriel synthesis.

In the light of the above statements, choose the correct answer from the options given below:

- (1) Statement I is incorrect but Statement II is true
 - (2) Both Statement I and Statement II are true
 - (3) Both Statement I and Statement II are false
 - (4) Statement I is correct but Statement II is false
-

63. Match List I with List II.

List I (Compound)	List II (Shape/Geometry)
A. NH_3	I. Trigonal Pyramidal
B. BrF_5	II. Square Planar
C. XeF_4	III. Octahedral
D. SF_6	IV. Square Pyramidal

Choose the correct answer from the options given below:

- (1) A-II, B-III, C-IV, D-I
- (2) A-II, B-IV, C-III, D-I
- (3) A-III, B-IV, C-II, D-I
- (4) A-II, B-III, C-I, D-IV

64. Match List I with List II.

List I (Quantum Number)	List II (Information Provided)
A. m_l	I. Shape of orbital
B. m_s	II. Size of orbital
C. l	III. Orientation of orbital
D. n	IV. Orientation of spin of electron

Choose the correct answer from the options given below:

- (1) A-II, B-I, C-IV, D-III
- (2) A-I, B-IV, C-III, D-II
- (3) A-III, B-IV, C-I, D-II
- (4) A-III, B-IV, C-II, D-I

65. The E^* value for the $\text{Mn}^{3+}/\text{Mn}^{2+}$ couple is more positive than that of $\text{Cr}^{3+}/\text{Cr}^{2+}$ or $\text{Fe}^{3+}/\text{Fe}^{2+}$ due to change of:

Choose the correct answer from the options given below:

- (1) $d^3 \rightarrow d^5$ configuration
- (2) $d^5 \rightarrow d^4$ configuration
- (3) $d^4 \rightarrow d^2$ configuration
- (4) $d^5 \rightarrow d^0$ configuration

66. In which of the following processes entropy increases?

- A. A liquid evaporates to vapour.
- B. Temperature of a crystalline solid lowered from 130 K to 0 K.
- C. $2\text{NaHCO}_3(s) \rightarrow \text{Na}_2\text{CO}_3(s) + \text{CO}_2(g) + \text{H}_2\text{O}(g)$
- D. $\text{Cl}_2(g) \rightarrow 2\text{Cl}(g)$

Choose the correct answer from the options given below:

- (1) C and D
- (2) A and C

(3) A, B and D

(4) A, C and D

67. The energy of an electron in the ground state ($n = 1$) for He^+ ion is $-x$ J, then that for an electron in $n = 2$ state for Be^{3+} ion in J is:

Choose the correct answer from the options given below:

(1) $-\frac{4}{9}x$

(2) $-\frac{x}{9}$

(3) $\frac{x}{9}$

(4) $-4x$

68. Which reaction is NOT a redox reaction?

Choose the correct answer from the options given below:

(1) $\text{BaCl}_2 + \text{Na}_2\text{SO}_4 \rightarrow \text{BaSO}_4 + 2\text{NaCl}$

(2) $\text{Zn} + \text{CuSO}_4 \rightarrow \text{ZnSO}_4 + \text{Cu}$

(3) $2\text{KClO}_3 + \text{I}_2 \rightarrow 2\text{KI}_3 + \text{Cl}_2$

(4) $\text{H}_2 + \text{Cl}_2 \rightarrow 2\text{HCl}$

69. Identify the correct reagents that would bring about the following transformation.

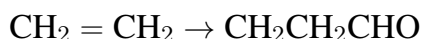

Choose the correct answer from the options given below:

(1) (i) $\text{H}_2\text{O}/\text{H}^+$, (ii) PCC, (iii) BH_3

(2) (i) $\text{H}_2\text{O}/\text{H}^+$, (ii) CrO_3 , (iii) PCC

(3) (i) $\text{H}_2\text{O}/\text{H}^+$, (ii) $\text{H}_2\text{O}_2/\text{OH}^-$, (iii) PCC

(4) (i) $\text{H}_2\text{O}/\text{H}^+$, (ii) $\text{H}_2\text{O}_2/\text{OH}^-$, (iii) alk. KMnO_4

70. On heating, some solid substances change from solid to vapour state without passing

through the liquid state. The technique used for the purification of such solid substances based on the above principle is known as:

Choose the correct answer from the options given below:

- (1) Chromatography
- (2) Crystallization
- (3) Sublimation
- (4) Distillation

71. Match List I with List II.

List I (Complex)	List II (Type of Isomerism)
A. $[Co(NH_3)_6](NO_2)_3$	I. Solvate Isomerism
B. $[Co(NH_3)_6](SO_4)_3$	II. Linkage Isomerism
C. $[Co(NH_3)_6][Cr(CN)_6]$	III. Ionization Isomerism
D. $[Co(NH_3)_6][Cl_3]$	IV. Coordination Isomerism

Choose the correct answer from the options given below:

- (1) A-I, B-IV, C-III, D-II
- (2) A-II, B-IV, C-I, D-I
- (3) A-I, B-III, C-IV, D-II
- (4) A-I, B-IV, C-III, D-I

72. Given below are two statements:

Statement I: Both $[Co(NH_3)_6]^{3+}$ and $[CoF_6]^{3+}$ complexes are octahedral but differ in their magnetic behaviour. Statement II: $[Co(NH_3)_6]^{3+}$ is diamagnetic whereas $[CoF_6]^{3+}$ is paramagnetic.

In the light of the above statements, choose the correct answer from the options given below:

- (1) Statement I is false but Statement II is true
- (2) Both Statement I and Statement II are true
- (3) Both Statement I and Statement II are false

(4) Statement I is true but Statement II is false

73. Fehling's solution 'A' is:

Choose the correct answer from the options given below:

- (1) aqueous sodium citrate
 - (2) aqueous copper sulphate
 - (3) alkaline copper sulphate
 - (4) alkaline solution of sodium potassium tartrate (Rochelle's salt)
-

74. Intramolecular hydrogen bonding is present in:

Choose the correct answer from the options given below:

- (1) HF
- (2) NO₂
- (3) OH₂
- (4) HO₂

75. Given below are two statements:

Statement I: The boiling point of three isomeric pentanes follows the order n-pentane > isopentane > neopentane. Statement II: When branching increases, the molecule attains a shape of sphere. This results in smaller surface area for contact, due to which the intermolecular forces between the spherical molecules are weak, thereby lowering the boiling point.

In the light of the above statements, choose the most appropriate answer from the options given below:

- (1) Statement I is incorrect but Statement II is correct
- (2) Both Statement I and Statement II are correct
- (3) Both Statement I and Statement II are incorrect
- (4) Statement I is correct but Statement II is incorrect

(3) 250 mg

(4) Zero mg

79. 'Spin only' magnetic moment is same for which of the following ions?

- A. Ti^{3+}
- B. Cr^{2+}
- C. Mn^{2+}
- D. Fe^{2+}
- E. Sc^{3+}

Choose the most appropriate answer from the options given below:

- (1) A and D only
- (2) B and D only
- (3) A and E only
- (4) B and C only

80. Match List I with List II.

List I (Reaction)	List II (Reagents/Condition)
A. $C_6H_5CH_2OH \rightarrow C_6H_5CHO$	I. $Cl/Anhyd. AlCl_3$
B. $C_6H_5OH \rightarrow C_6H_5COOH$	II. CrO_3
C. $C_6H_5CH_3 \rightarrow C_6H_5COOK$	III. $KMnO_4/KOH, \Delta$
D. $C_6H_5CH_3 \rightarrow C_6H_5CHO$	IV. (i) O_3 (ii) $Zn-H_2O$

Choose the correct answer from the options given below:

- (1) A-I, B-IV, C-III, D-II
- (2) A-II, B-IV, C-I, D-II
- (3) A-III, B-I, C-IV, D-II
- (4) A-IV, B-I, C-III, D-II

81. Match List I with List II.

List I (Molecule)	List II (Number and types of bonds between two carbon atoms)
A. ethane	I. one σ -bond and two π -bonds
B. ethene	II. two π -bonds
C. carbon molecule, C_2	III. one σ -bond
D. ethyne	IV. one σ -bond and one π -bond

Choose the correct answer from the options given below:

- (1) A-III, B-IV, C-I, D-II
- (2) A-I, B-IV, C-I, D-II
- (3) A-IV, B-III, C-II, D-I
- (4) A-I, B-IV, C-II, D-I

82. The compound that will undergo S_N1 reaction with the fastest rate is:

Choose the correct answer from the options given below:

- (1) CH_3CH_2Br
- (2) C_6H_5Br
- (3) CH_3CCl_3
- (4) C_6H_4Br

83. Arrange the following elements in increasing order of first ionization enthalpy: Li, Be, B, C, N.

Choose the correct answer from the options given below:

- (1) Li \uparrow Be \uparrow N \uparrow B \uparrow C
- (2) Li \uparrow Be \uparrow B \uparrow C \uparrow N
- (3) Li \uparrow Be \uparrow C \uparrow B \uparrow N
- (4) Li \uparrow Be \uparrow C \uparrow B \uparrow N

84. The reagents with which glucose does not react to give the corresponding tests/products are: A. Tollen's reagent B. Schiff's reagent C. HCN D. NH_2OH E. $NaHSO_3$

Choose the correct options from the given below:

- (1) E and D
- (2) B and C
- (3) A and D
- (4) B and E

85. Match List I with List II.

List I (Process)	List II (Conditions)
A. Isothermal process	I. No heat exchange
B. Isochoric process	II. Carried out at constant temperature
C. Isobaric process	III. Carried out at constant volume
D. Adiabatic process	IV. Carried out at constant pressure

Choose the correct answer from the options given below:

- (1) A-I, B-III, C-IV, D-II
- (2) A-IV, B-III, C-I, D-II
- (3) A-IV, B-II, C-III, D-I
- (4) A-I, B-IV, C-II, D-I

86. During the preparation of Mohr's salt solution (Ferrous ammonium sulphate), which of the following acid is added to prevent hydrolysis of Fe^{2+} ion?

Choose the correct answer from the options given below:

- (1) dilute sulphuric acid
- (2) dilute hydrochloric acid
- (3) concentrated sulphuric acid
- (4) dilute nitric acid

87. Identify the correct answer.

Choose the correct option from the following:

- (1) Three canonical forms can be drawn for CO_3^{2-} ion

- (2) Three resonance structures can be drawn for ozone
 - (3) BF_3 has non-zero dipole moment
 - (4) Dipole moment of NF_2 is greater than that of NH_3
-

88. A compound X contains 32% of A, 20% of B and remaining percentage of C. Then, the empirical formula of X is:

(Given atomic masses of A = 64; B = 40; C = 32)

Choose the correct answer from the options given below:

- (1) ABC_4
 - (2) A_2BC_2
 - (3) ABC_3
 - (4) AB_2C_2
-

89. Given below are certain cations. Using inorganic qualitative analysis, arrange them in increasing group number from 0 to VI. A. Al^{3+} , B. Cu^{2+} , C. Ba^{2+} , D. Co^{2+} , E. Mg^{2+}

Choose the correct answer from the options given below:

- (1) E, A, B, C, D
 - (2) B, A, D, C, E
 - (3) B, C, A, D, E
 - (4) E, A, C, D, B
-

90. The work done during reversible isothermal expansion of one mole of hydrogen gas at 25°C from pressure of 20 atmosphere to 10 atmosphere is:

(Given $R = 2.0 \text{ cal K}^{-1} \text{ mol}^{-1}$)

Choose the correct answer from the options given below:

- (1) 100 calories
- (2) 0 calories
- (3) -413.14 calories
- (4) 413.14 calories

91. The plot of osmotic pressure (Π) vs concentration (mol L^{-1}) for a solution gives a straight line with slope $25.73 \text{ L bar mol}^{-1}$. The temperature at which the osmotic pressure measurement is done is:

(Use $R = 0.083 \text{ L bar mol}^{-1} \text{ K}^{-1}$)

Choose the correct answer from the options given below:

- (1) 12.05°C
 - (2) 37°C
 - (3) 310°C
 - (4) 25.73°C
-

92. Major products A and B formed in the following reaction sequence, are:

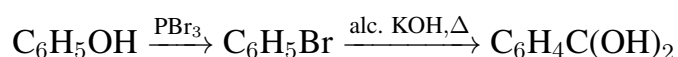

Choose the correct answer from the options given below:

- (1) $\text{A} = \text{B} = \text{C}_6\text{H}_5\text{OH}$
 - (2) $\text{A} = \text{C}_6\text{H}_5\text{Br}$, $\text{B} = \text{C}_6\text{H}_4\text{C}(\text{OH})_2$
 - (3) $\text{A} = \text{C}_6\text{H}_5\text{Br}$, $\text{B} = \text{C}_6\text{H}_4\text{Br}$
 - (4) $\text{A} = \text{C}_6\text{H}_4\text{Br}$, $\text{B} = \text{C}_6\text{H}_5\text{OH}$
-

93. Mass in grams of copper deposited by passing 9.6487 A current through a voltmeter containing copper sulphate solution for 100 seconds is (Given: Molar mass of $\text{Cu} = 63 \text{ g mol}^{-1}$, $1 \text{ F} = 96487 \text{ C}$)

Choose the correct answer from the options given below:

- (1) 0.0315 g
- (2) 3.15 g
- (3) 0.315 g
- (4) 31.5 g

94. Consider the following reaction in a sealed vessel at equilibrium with concentrations of $\text{N}_2 = 3.0 \times 10^{-3} \text{ M}$, $\text{O}_2 = 4.2 \times 10^{-3} \text{ M}$, and $\text{NO} = 2.8 \times 10^{-3} \text{ M}$.

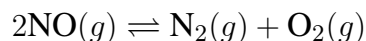

If 0.1 mol L^{-1} of $\text{NO}(g)$ is taken in a closed vessel, what will be the degree of dissociation (α) of $\text{NO}(g)$ at equilibrium?

Choose the correct answer from the options given below:

- (1) 0.717
- (2) 0.00889
- (3) 0.0889
- (4) 0.8889

95. Identify the major product C formed in the following reaction sequence:

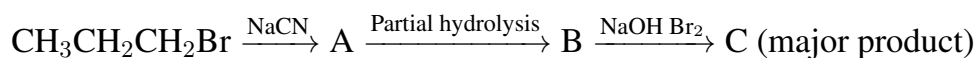

Choose the correct answer from the options given below:

- (1) α -bromobutanoic acid
- (2) propylamine
- (3) butylamine
- (4) butanamide

Solution: The major product after the complete reaction sequence is propylamine (Option 2). The initial reaction with NaCN leads to a nitrile, followed by hydrolysis and treatment with NaOH and Br_2 .

96. The pair of lanthanoid ions which are diamagnetic is:

Choose the correct answer from the options given below:

- (1) Pm^{3+} and Sm^{3+}
- (2) Ce^{4+} and Yb^{2+}

(3) Ce^{3+} and Eu^{2+}

(4) Gd^{3+} and Eu^{3+}

97. For the given reaction:

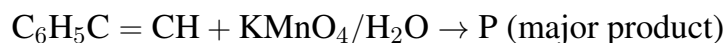

Choose the correct answer from the options given below:

(1) COOH

(2) CHO

(3) COOH

(4) $\text{C}_6\text{H}_4\text{OH}$

98. Given below are two statements:

Statement I: $[\text{Co}(\text{NH}_3)_6]^{3+}$ is a homoleptic complex whereas $[\text{Co}(\text{NH}_3)_5\text{Cl}]^{2+}$ is a heteroleptic complex. Statement II: Complex $[\text{Co}(\text{NH}_3)_6]^{3+}$ has only one kind of ligands but $[\text{Co}(\text{NH}_3)_5\text{Cl}]^{2+}$ has more than one kind of ligands.

In the light of the above statements, choose the correct answer from the options given below:

(1) Statement I is false but Statement II is true

(2) Both Statement I and Statement II are true

(3) Both Statement I and Statement II are false

(4) Statement I is true but Statement II is false

99. The rate of a reaction quadruples when temperature changes from 27°C to 57°C . Calculate the energy of activation.

Given $R = 8.314 \text{ J K}^{-1} \text{ mol}^{-1}$, $\log 4 = 0.6021$

Choose the correct answer from the options given below:

(1) 3804 kJ/mol

- (2) 38.04 kJ/mol
 - (3) 380.4 kJ/mol
 - (4) 3.80 kJ/mol
-

100. The products A and B obtained in the following reactions, respectively, are:

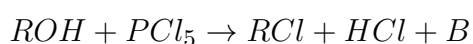

Choose the correct answer from the options given below:

- (1) H_3PO_4 and PCl_3
 - (2) PCl_3 and H_3PO_3
 - (3) PCl_3 and H_3PO_4
 - (4) H_3PO_3 and PCl_3
-

101. The lactose present in the growth medium of bacteria is transported to the cell by the action of:

- (1) Polymerase (2) Beta-galactosidase (3) Acetylase (4) Permease

102. Lecithin, a small molecular weight organic compound found in living tissues, is an example of:

- (1) Carbohydrates (2) Amino acids (3) Phospholipids (4) Glycerides
-

103. Match List I with List II

List I	List II
A. <i>Clostridium butylicum</i>	I. Ethanol
B. <i>Saccharomyces cerevisiae</i>	II. Streptokinase

C. *Trichoderma polyspermum* III. Butyric acid

D. *Streptococcus* sp. IV. Cyclosporin-A

Choose the correct answer from the options given below:

(1) A-IV, B-I, C-III, D-II (2) A-III, B-I, C-II, D-IV (3) A-II, B-IV, C-III, D-I (4) A-III, B-I, C-IV, D-I

104. The equation of Verhulst-Pearl logistic growth is

$$\frac{dN}{dt} = rN \left(\frac{K - N}{K} \right)$$

From this equation, K indicates:

(1) Population density (2) Intrinsic rate of natural increase (3) Biotic potential (4) Carrying capacity

105. Hind II always cuts DNA molecules at a particular point called recognition sequence and it consists of:

(1) 10 bp (2) 8 bp (3) 6 bp (4) 4 bp

106. Formation of interfascicular cambium from fully developed parenchyma cells is an example for:

(1) Maturation (2) Differentiation (3) Redifferentiation (4) Dedifferentiation

107. Inhibition of Succinic dehydrogenase enzyme by malonate is a classical example of:

(1) Enzyme activation (2) Cofactor inhibition (3) Feedback inhibition (4) Competitive inhibition

108. List of endangered species was released by:

(1) IUCN (2) GEAC (3) WWF (4) FOAM

109. Spindle fibers attach to kinetochore of chromosomes during:

- (1) Telophase (2) Prophase (3) Metaphase (4) Anaphase
-

110. How many molecules of ATP and NADPH are required for every molecule of CO₂ fixed in the Calvin cycle?

- (1) 3 molecules of ATP and 2 molecules of NADPH (2) 2 molecules of ATP and 3 molecules of NADPH
-

111. Match List I with List II

List I List II

- | | |
|---|----------------|
| A. Two or more alternative forms of a gene | I. Back cross |
| B. Cross of F ₁ progeny with homozygous recessive parent | II. Ploidy |
| C. Cross of F ₁ progeny with any of the parents | III. Allele |
| D. Number of chromosome sets in plant | IV. Test cross |

Choose the correct answer from the options given below:

- (1) A-IV, B-III, C-II, D-I (2) A-I, B-II, C-III, D-IV (3) A-II, B-I, C-III, D-IV (4) A-III, B-IV, C-I, D-II
-

112. Match List I with List II

List I List II

- | | |
|-------------|------------------|
| A. Rhizopus | I. Mushroom |
| B. Ustilago | II. Smut fungus |
| C. Puccinia | III. Bread mould |

D. Agaricus IV. Rust fungus

Choose the correct answer from the options given below:

- (1) A-IV, B-III, C-II, D-I (2) A-III, B-II, C-IV, D-I (3) A-I, B-III, C-II, D-IV (4) A-I, B-II, C-III, D-IV
-

113. Given below are two statements:

Statement I: Chromosomes become gradually visible under light microscope during leptotene stage. Statement II: The beginning of diplotene stage is recognized by dissolution of synaptonemal complex.

In the light of the above statements, choose the correct answer from the options given below:

- (1) Statement I is false but Statement II is true (2) Both Statement I and Statement II are true (3) Both Statement I and Statement II are false
-

114. Identify the part of the seed from the given figure which is destined to form root when the seed germinates.

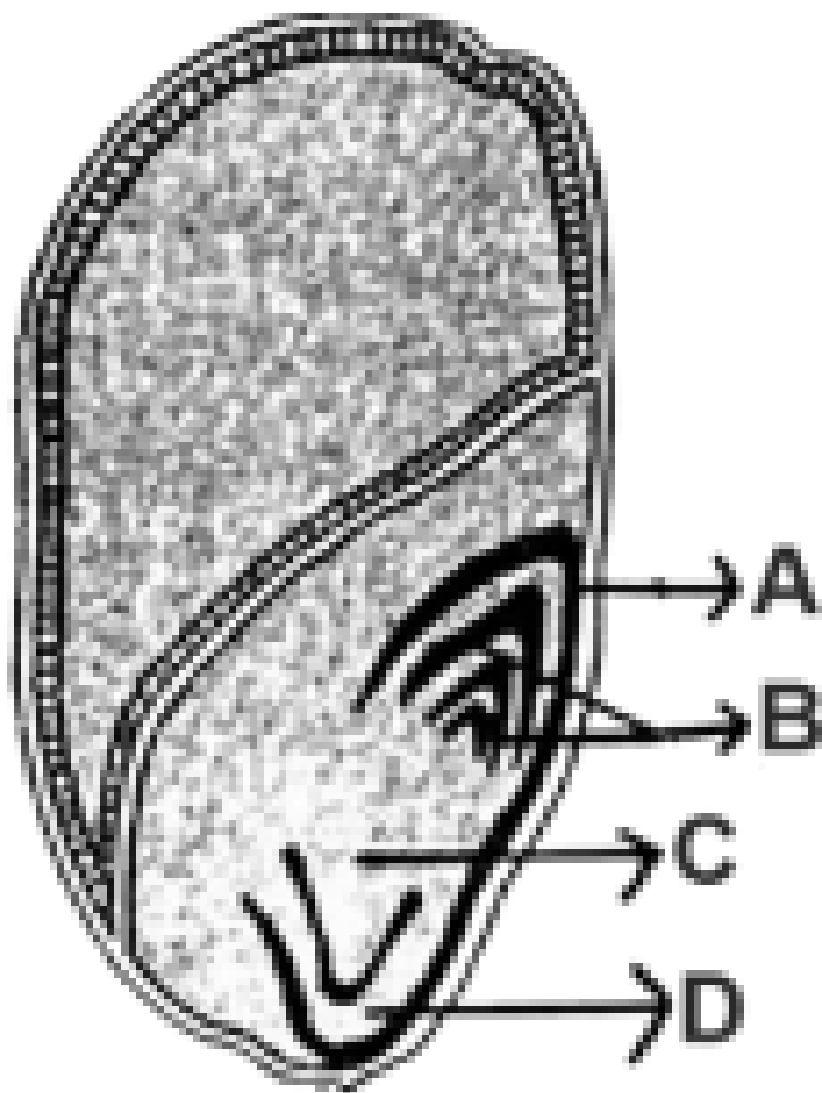

(1) D (2) A (3) B (4) C

115. In a plant, black seed color (BB/Bb) is dominant over white seed color (bb). In order to find out the genotype of the black seed plant, with which of the following genotype will you cross it?

(1) BB/Bb (2) BB (3) bb (4) Bb

116. Bulliform cells are responsible for:

(1) Providing large spaces for storage of sugars (2) Inward curling of leaves in monocots (3) Protection

117. Which one of the following can be explained on the basis of Mendel's Law of Dominance?

- A. Out of one pair of factors one is dominant and the other is recessive. B. Alleles do not show any expression in heterozygous condition.
C. Factors occur in pairs in normal diploid plants. D. The discrete unit controlling a particular character is called a gene.

Choose the correct answer from the options given below:

- (1) A, B, C, D and E (2) A, B and C only (3) A, C, D and E only (4) B, C and D only

118. The cofactor of the enzyme carboxypeptidase is:

- (1) Haem (2) Zinc (3) Niacin (4) Flavin
-

119. A transcription unit in DNA is defined primarily by the three regions in DNA and these are with respect to upstream and downstream end;

- (1) Promotor, Structural gene, Terminator (2) Repressor, Operator gene, Structural gene
(3) Structural gene, Transposons, Operator gene (4) Inducer, Repressor, Structural gene
-

120. Tropical regions show greatest level of species richness because:

- A. Tropical latitudes have remained relatively undisturbed for millions of years, hence more time was available for speciation.
B. High temperature and high humidity favour a large number of species.
C. More solar energy is available in tropics. D. Constant environments promote niche specialization.

Choose the correct answer from the options given below:

- (1) A, B and D only (2) A, C, D and E only (3) A and B only (4) A, B and E only
-

121. Given below are two statements:

Statement I: Parenchyma is living but collenchyma is dead tissue. Statement II: Gymnosperms lack xylem vessels but the presence of xylem vessels is the characteristic of angiosperms.

In the light of the above statements, choose the correct answer from the options given below:

- (1) Statement I is false but Statement II is true (2) Both Statement I and Statement II are true (3) Both
-

122. The type of conservation in which the threatened species are taken out from their natural habitat and placed in special setting where they can be protected and given special care is called:

- (1) Sustainable development (2) In-situ conservation (3) Biodiversity conservation (4) Semi-conservation
-

123. Which of the following are required for the dark reaction of photosynthesis?

A. Light B. Chlorophyll C. CO₂ D. ATP E. NADPH

Choose the correct answer from the options given below:

- (1) D and E only (2) A, B and C only (3) B, C and D only (4) C, D and E only
-