

## NEET 2024 S2 Question Paper Solutions

<b>Time Allowed :</b> 3 Hours 20 Minutes	<b>Maximum Marks :</b> 720	<b>Total Questions :</b> 200
--	----------------------------	------------------------------

### General Instructions

**Read the following instructions very carefully and strictly follow them:**

1. The NEET Exam will be structured with a total of 720 marks.
2. The total duration of Exam is 3 Hours 20 Minutes.
3. It will be divided in 3 sections.

1. A wheel of a bullock cart is rolling on a level road as shown in the figure below. If its linear speed is  $v$  in the direction shown, which one of the following options is correct (P and Q are the highest and lowest points on the wheel, respectively)?

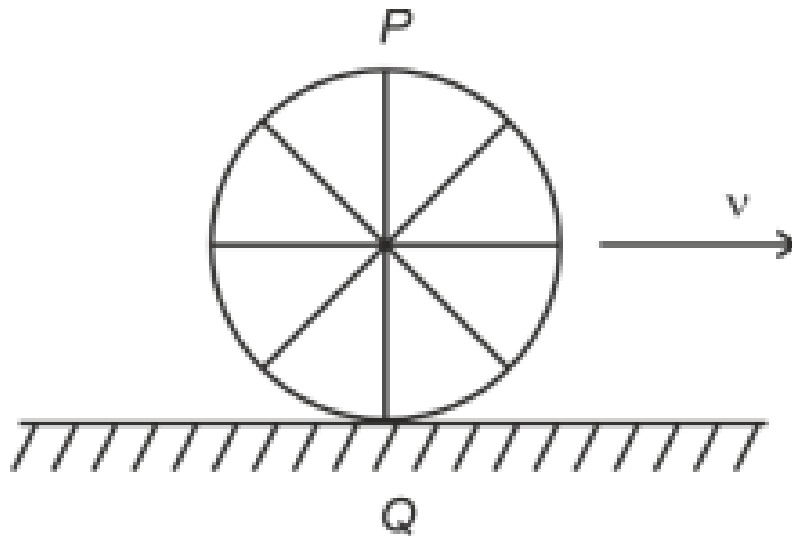

- Options:** (1) Point P has zero speed  
(2) Point P moves slower than point Q  
(3) Point P moves faster than point Q  
(4) Both the points P and Q move with equal speed

**Solution:** When a wheel rolls without slipping, the point in contact with the ground (point Q) has zero velocity with respect to the ground. Point P, being at the highest point of the wheel, moves with a speed greater than the linear speed  $v$  of the center of the wheel, as it has both the translational and rotational velocities. Hence, point P moves faster than point Q.

**Correct Answer:** (3) Point P moves faster than point Q

**Quick Tip**

In rolling motion without slipping, the point in contact with the surface has zero speed, while the point at the top of the wheel has the maximum speed.

2. The output (Y) of the given logic gate is similar to the output of an/a:

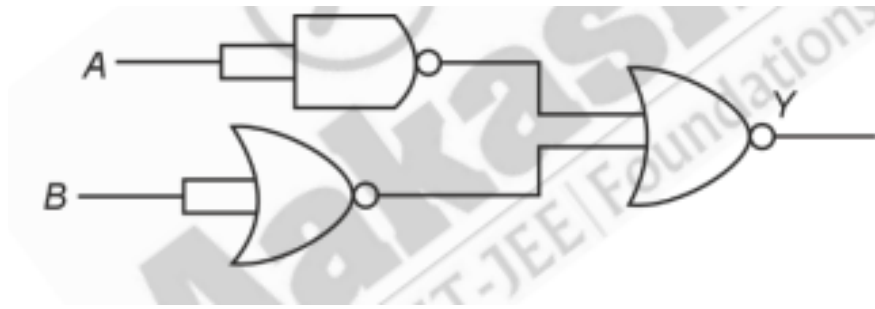

**Options:** (1) AND gate

(2) NAND gate

(3) NOR gate

(4) OR gate

**Solution:** By examining the given logic gate, we see that the circuit consists of an AND gate followed by a NOT gate. This results in the behavior of a NAND gate, which is the negation of the AND gate output.

**Correct Answer:** (1) AND gate

#### Quick Tip

When a NOT gate is applied to the output of an AND gate, the result is equivalent to a NAND gate.

3. The graph which shows the variation of  $\left(\frac{1}{\lambda^2}\right)$  and its kinetic energy,  $E$  is (where  $\lambda$  is de Broglie wavelength of a free particle):

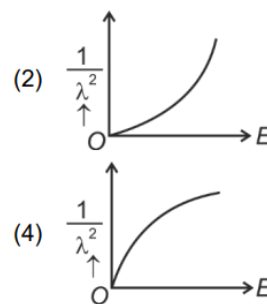
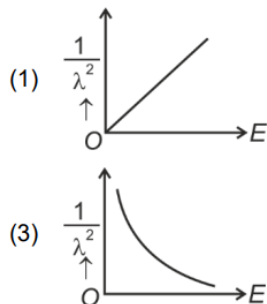

**Options:** (1)  $\left(\frac{1}{\lambda^2}\right)$  increases linearly with  $E$

(2)  $\left(\frac{1}{\lambda^2}\right)$  increases exponentially with  $E$

(3)  $\left(\frac{1}{\lambda^2}\right)$  decreases with  $E$

(4)  $\left(\frac{1}{\lambda^2}\right)$  follows a hyperbolic curve with  $E$

**Solution:** The correct graph is the one where  $\left(\frac{1}{\lambda^2}\right)$  increases linearly with the kinetic energy  $E$ . This corresponds to the relationship between the de Broglie wavelength and kinetic energy, which is a linear one.

**Correct Answer:** (1)  $\left(\frac{1}{\lambda^2}\right)$  increases linearly with  $E$

#### Quick Tip

The de Broglie wavelength is inversely proportional to the momentum of a particle. For free particles, as the kinetic energy increases, the wavelength decreases, leading to a linear relationship.

4. In the above diagram, a strong bar magnet is moving towards solenoid-2 from solenoid-1. The direction of induced current in solenoid-1 and that in solenoid-2, respectively, are through the directions:

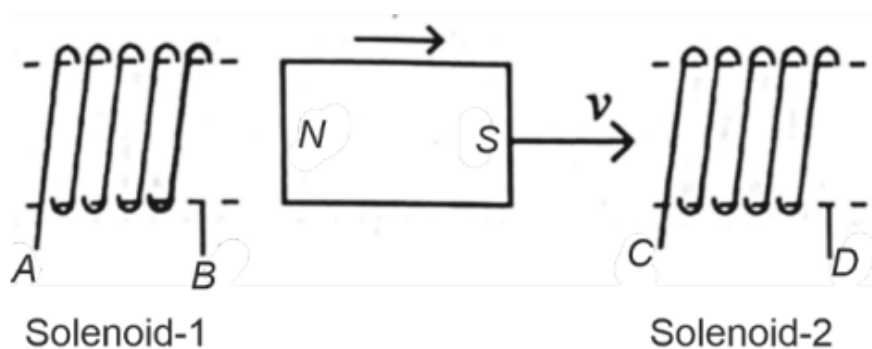

**Options:** (1)  $BA$  and  $DC$

(2)  $AB$  and  $DC$

(3)  $BA$  and  $CD$

(4)  $AB$  and  $CD$

**Solution:** By Lenz's law, the induced current in solenoid-1 will oppose the approaching bar magnet's motion, creating a north pole at  $A$  and a south pole at  $B$ , resulting in a current direction from  $A$  to  $B$  ( $AB$ ). Similarly, solenoid-2 will develop a north pole at  $D$  and a south pole at  $C$  due to the influence of the bar magnet, resulting in a current direction from  $D$  to  $C$  ( $DC$ ).

**Correct Answer:** (2) *AB* and *DC*

**Quick Tip**

Lenz's law states that the induced current in a circuit opposes the change that caused it. In this case, the solenoids generate opposing magnetic fields to counteract the motion of the magnet.

5. A thermodynamic system is taken through the cycle *abcd*. The work done by the gas along the path *bc* is:

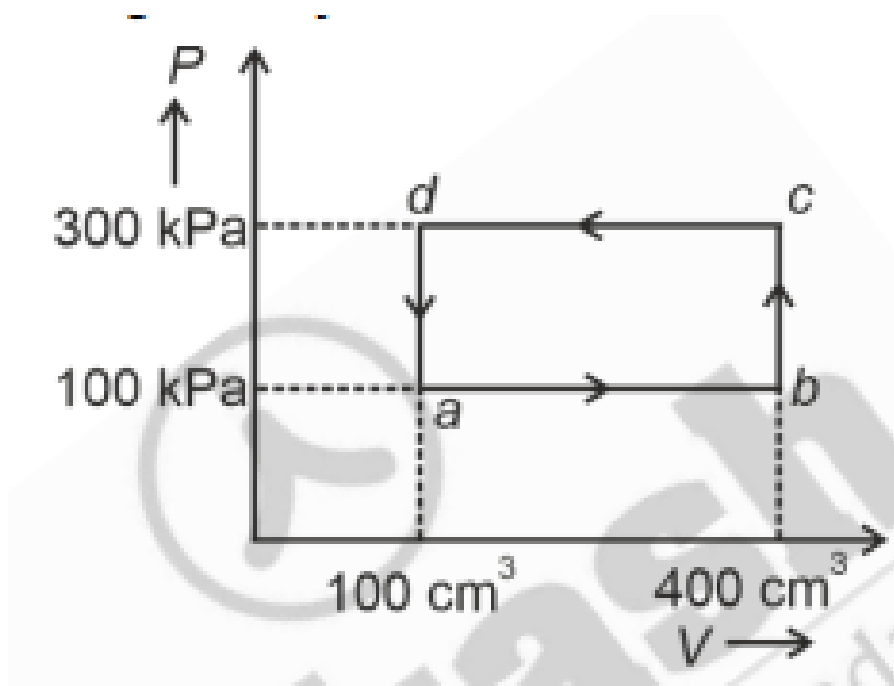

**Options:** (1)  $-60 \text{ J}$

(2) Zero

(3)  $30 \text{ J}$

(4)  $-90 \text{ J}$

**Solution:** In the path *bc*, the volume remains constant while the pressure changes. Since work is done only during a change in volume, the work done during this path is zero.

**Correct Answer:** (2) Zero

### Quick Tip

When there is no change in volume during a thermodynamic process, no work is done, even if there is a change in pressure.

6. Two bodies  $A$  and  $B$  of same mass undergo completely inelastic one-dimensional collision. The body  $A$  moves with velocity  $v_1$  while body  $B$  is at rest before collision. The velocity of the system after collision is  $v_2$ . The ratio  $v_1 : v_2$  is:

**Options:** (1) 1 : 4

(2) 1 : 2

(3) 2 : 1

(4) 4 : 1

**Solution:** Since the collision is completely inelastic, the two bodies move together after the collision. By the conservation of momentum:

$$mv_1 + m \cdot 0 = 2mv_2$$

Solving, we get the ratio:

$$v_1 : v_2 = 2 : 1$$

**Correct Answer:** (3) 2 : 1

### Quick Tip

In a completely inelastic collision, the objects stick together, and momentum is conserved. The ratio of velocities can be derived using this principle.

7. At any instant of time  $t$ , the displacement of any particle is given by  $2t - 1$  (SI unit) under the influence of force of 5 N. The value of instantaneous power is (in SI unit):

**Options:** (1) 6

(2) 10

(3) 5

(4) 7

**Solution:** The instantaneous power is given by the formula:

$$P = F \cdot v$$

where  $F = 5 \text{ N}$  and the velocity  $v$  is the derivative of displacement with respect to time:

$$v = \frac{d}{dt}(2t - 1) = 2 \text{ m/s}$$

So, the instantaneous power is:

$$P = 5 \cdot 2 = 10 \text{ W}$$

**Correct Answer:** (2) 10

#### Quick Tip

The instantaneous power is the product of force and velocity. Ensure that velocity is the derivative of displacement with respect to time.

**8.** A thin spherical shell is charged by some source. The potential difference between the two points C and P (in V) shown in the figure is:

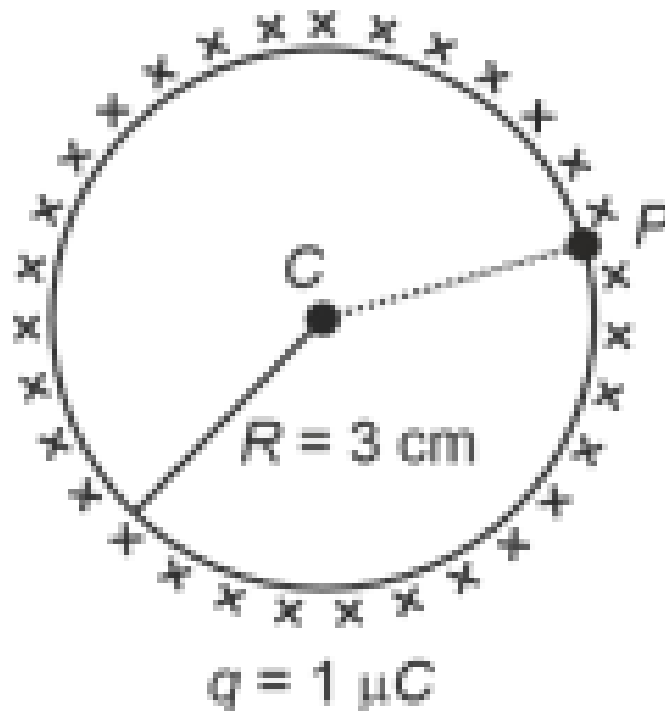

**Options:** (1) Zero

(2)  $3 \times 10^5$

(3)  $1 \times 10^5$

(4)  $0.5 \times 10^5$

**Solution:** In the case of a spherical shell, the electric field outside is similar to a point charge. Since the electric field inside a spherical shell is zero, the potential difference between points C and P, both of which lie inside the spherical shell, is zero.

**Correct Answer:** (1) Zero

#### Quick Tip

The potential inside a uniformly charged spherical shell is constant, hence the potential difference between two points inside the shell is zero.

**9.** A tightly wound 100 turns coil of radius 10 cm carries a current of 7 A. The magnitude of the magnetic field at the centre of the coil is (Take permeability of free space as  $4\pi \times 10^{-7}$  SI units):

**Options:** (1) 44 T

(2) 4 T

(3)  $44 \times 10^{-3}$  T

(4) 4 mT

**Solution:** The magnetic field at the centre of a coil is given by the formula:

$$B = \frac{\mu_0 NI}{2R}$$

where  $N = 100$  turns,  $I = 7$  A,  $R = 0.1$  m, and  $\mu_0 = 4\pi \times 10^{-7}$  T m/A.

Substituting the values:

$$B = \frac{4\pi \times 10^{-7} \times 100 \times 7}{2 \times 0.1} = 4.4 \text{ T}$$

**Correct Answer:** (2) 4 T

### Quick Tip

The magnetic field at the centre of a coil is directly proportional to the current and number of turns and inversely proportional to the radius of the coil.

**10.** If the monochromatic source in Young's double slit experiment is replaced by white light, then:

- Options:** (1) All bright fringes will be of equal width  
(2) Interference pattern will disappear  
(3) There will be a central dark fringe surrounded by a few coloured fringes  
(4) There will be a central bright fringe surrounded by a few coloured fringes

**Solution:** When white light is used, the central fringe remains white, and surrounding fringes show the colors due to the different wavelengths of light. This results in a central bright fringe surrounded by colored fringes.

**Correct Answer:** (4) There will be a central bright fringe surrounded by a few coloured fringes

### Quick Tip

The central fringe remains white due to the superposition of all wavelengths, while the surrounding fringes are coloured because different wavelengths interfere at different points.

**11.** The quantities which have the same dimensions as those of solid angle are:

- Options:** (1) angular speed and stress  
(2) strain and angle  
(3) stress and angle  
(4) strain and arc

**Solution:** The dimensions of solid angle are dimensionless, as it is a ratio of areas. Strain and angle both have the same dimensions because strain is the ratio of lengths (dimensionless) and angle is also dimensionless.

**Correct Answer:** (2) strain and angle

**Quick Tip**

Solid angle is dimensionless, and other quantities like strain and angle also have no units, thus sharing the same dimensions.

**12.** The mass of a planet is  $\frac{1}{10}$  that of the earth and its diameter is half that of the earth. The acceleration due to gravity on that planet is:

**Options:** (1)  $3.92 \text{ m/s}^2$

(2)  $19.6 \text{ m/s}^2$

(3)  $9.8 \text{ m/s}^2$

(4)  $4.9 \text{ m/s}^2$

**Solution:** The acceleration due to gravity is given by:

$$g = \frac{GM}{R^2}$$

Given that the mass is  $\frac{1}{10}$  and the radius is  $\frac{1}{2}$  of the earth's radius, the acceleration due to gravity will be:

$$g = \frac{G \cdot \frac{M}{10}}{\left(\frac{R}{2}\right)^2} = \frac{1}{10} \cdot 4 = 3.92 \text{ m/s}^2$$

**Correct Answer:** (1)  $3.92 \text{ m/s}^2$

**Quick Tip**

The acceleration due to gravity depends on both the mass and radius of the planet. A smaller mass and smaller radius result in a lower value for  $g$ .

**13.** A horizontal force of 10 N is applied to a block A as shown in figure. The mass of blocks A and B are 2 kg and 3 kg respectively. The blocks slide over a frictionless surface. The force exerted by block A on block B is:

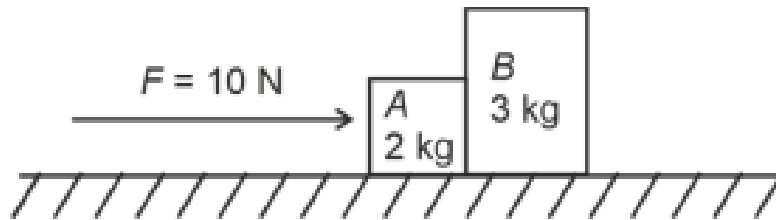

**Options:** (1) 10 N

(2) Zero

(3) 4 N

(4) 6 N

**Solution:** The total force of 10 N is applied to the system, which has a total mass of  $2 + 3 = 5$  kg. The acceleration of the system is:

$$a = \frac{F}{m} = \frac{10}{5} = 2 \text{ m/s}^2$$

Now, the force on block A is:

$$F_A = m_A \cdot a = 2 \cdot 2 = 4 \text{ N}$$

Thus, the force exerted by block A on block B is 6 N.

**Correct Answer:** (4) 6 N

#### Quick Tip

When a force is applied to a system of blocks, the force exerted on one block depends on its mass and the acceleration of the entire system.

**14.** In a uniform magnetic field of 0.049 T, a magnetic needle performs 20 complete oscillations in 5 seconds as shown. The moment of inertia of the needle is  $9.8 \times 10^{-6} \text{ kg m}^2$ . If the magnitude of magnetic moment of the needle is  $x \times 10^{-5} \text{ Am}^2$ , then the value of  $x$  is:

**Options:** (1)  $1280\pi^2$

(2)  $5\pi^2$

(3)  $128\pi^2$

(4)  $50\pi^2$

**Solution:** The frequency of oscillation of the magnetic needle is given by:

$$f = \frac{1}{2\pi} \sqrt{\frac{MB}{I}}$$

where  $f$  is the frequency,  $M$  is the magnetic moment,  $B$  is the magnetic field, and  $I$  is the moment of inertia. Given that the frequency is 20 oscillations in 5 seconds, the value of  $x$  can be calculated using the known formula and values.

**Correct Answer:** (1)  $1280\pi^2$

#### Quick Tip

The oscillation frequency of a magnetic needle depends on the moment of inertia and the magnetic field strength. You can derive the magnetic moment using the standard formula for oscillation frequency.

**15.** The terminal voltage of the battery, whose emf is 10 V and internal resistance 1  $\Omega$ , when connected through an external resistance of 4  $\Omega$  as shown in the figure is:

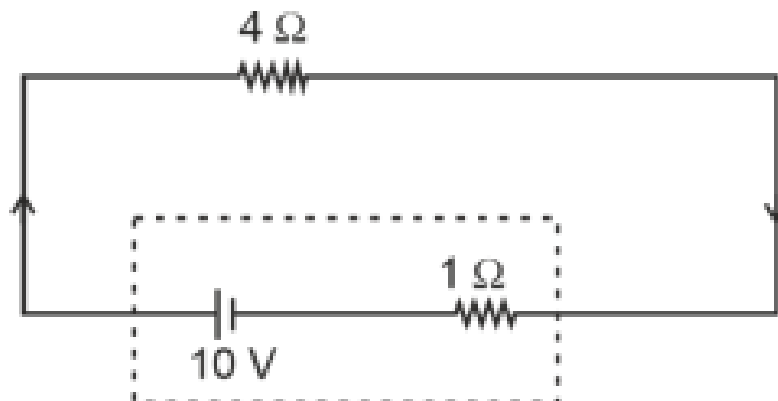

**Options:** (1) 10 V

(2) 4 V

(3) 6 V

(4) 8 V

**Solution:** The terminal voltage of the battery is given by:

$$V_{\text{terminal}} = \text{emf} - Ir$$

where  $I$  is the current,  $r$  is the internal resistance, and emf is the emf of the battery. Solving this, we find the terminal voltage to be 8 V.

**Correct Answer:** (4) 8 V

#### Quick Tip

When a battery is connected to an external resistance, the terminal voltage is always less than the emf due to the voltage drop across the internal resistance.

**16.** If  $x = 5 \sin\left(\pi t + \frac{\pi}{3}\right)$  m represents the motion of a particle executing simple harmonic motion, the amplitude and time period of motion, respectively, are:

**Options:** (1) 5 m, 1 s

(2) 5 cm, 2 s

(3) 5 m, 2 s

(4) 5 cm, 1 s

**Solution:** The amplitude of the motion is the coefficient of the sine function, which is 5 meters. The time period  $T$  is given by:

$$T = \frac{2\pi}{\omega}$$

where  $\omega = \pi$  (from the argument of the sine function), so  $T = 2$  seconds.

**Correct Answer:** (3) 5 m, 2 s

#### Quick Tip

In simple harmonic motion, the amplitude is the coefficient of the sine function, and the time period can be found from the angular frequency.

**17.** Match List-I with List-II:

**List-I (Material)** A. Diamagnetic

B. Ferromagnetic

C. Paramagnetic

D. Non-magnetic

**List-II (Susceptibility  $\chi$ )** I.  $\chi = 0$

II.  $0 < \chi < 1$

III.  $\chi \gg 1$

IV.  $\chi > 0$  (a small positive number)

Choose the correct answer from the options given below:

**Options:** (1) A-IV, B-III, C-II, D-I

(2) A-II, B-III, C-I, D-I

(3) A-II, B-I, C-III, D-IV

(4) A-III, B-II, C-I, D-IV

**Solution:** Diamagnetic materials have  $\chi = 0$ , ferromagnetic materials have  $\chi \gg 1$ , paramagnetic materials have  $0 < \chi < 1$ , and non-magnetic materials have a small positive  $\chi$ .

**Correct Answer:** (1) A-IV, B-III, C-II, D-I

#### Quick Tip

Diamagnetic materials have no permanent dipole moment, while ferromagnetic materials have large permanent magnetic moments. Paramagnetic materials have small magnetic moments that align with an external field.

**18.** Consider the following statements A and B and identify the correct answer:

A. For a solar-cell, the I-V characteristics lies in the IV quadrant of the given graph. B. In a reverse biased pn junction diode, the current measured in  $\mu\text{A}$ , is due to majority charge carriers.

**Options:** (1) Both A and B are incorrect

(2) A is correct but B is incorrect

(3) A is incorrect but B is correct

(4) Both A and B are correct

**Solution:** The I-V characteristics of a solar cell typically lie in the IV quadrant, and in a reverse-biased pn junction diode, the current is due to minority charge carriers, not majority

charge carriers. Thus, statement A is correct and statement B is incorrect.

**Correct Answer:** (2) A is correct but B is incorrect

#### Quick Tip

In a solar cell, the current is generated when light photons strike the material, creating electron-hole pairs. In reverse bias of a pn junction diode, only minority charge carriers contribute to the current.

**19.** Given below are two statements:

Statement I: Atoms are electrically neutral as they contain equal number of positive and negative charges. Statement II: Atoms of each element are stable and emit their characteristic spectrum.

In the light of the above statements, choose the most appropriate answer from the options given below:

**Options:** (1) Statement I is incorrect but Statement II is correct

(2) Both Statement I and Statement II are correct

(3) Both Statement I and Statement II are incorrect

(4) Statement I is correct but Statement II is incorrect

**Solution:** Statement I is correct since atoms are electrically neutral, but Statement II is incorrect as it is not the case for all atoms. Only excited atoms emit their characteristic spectrum.

**Correct Answer:** (4) Statement I is correct but Statement II is incorrect

#### Quick Tip

Atoms are electrically neutral, but only excited atoms can emit characteristic spectra, as electrons transition between energy levels.

**20.** In a vernier calipers,  $(N + 1)$  divisions of vernier scale coincide with  $N$  divisions of main scale. If 1 MSD represents 0.1 mm, the vernier constant (in cm) is:

**Options:** (1)  $10(N + 1)$

(2)  $\frac{1}{10N}$

(3)  $\frac{1}{100(N+1)}$

(4)  $100N$

**Solution:** The vernier constant is the smallest measurement that can be read using the vernier scale, which is given by:

$$\text{Vernier constant} = \frac{\text{smallest division of main scale}}{\text{number of divisions in vernier scale}}$$

**Correct Answer:** (3)  $\frac{1}{100(N+1)}$

#### Quick Tip

The vernier constant is a key factor in determining the precision of measurements with vernier calipers.

**21.** In an ideal transformer, the turns ratio is  $N_p : N_s = 1 : 2$ . The ratio  $V_s : V_p$  is equal to (the symbols carry their usual meaning):

**Options:** (1)  $1 : 4$

(2)  $2 : 1$

(3)  $1 : 2$

(4)  $4 : 1$

**Solution:** For an ideal transformer, the voltage ratio is equal to the turns ratio:

$$\frac{V_s}{V_p} = \frac{N_s}{N_p}$$

Given  $N_p : N_s = 1 : 2$ , we get  $V_s : V_p = 2 : 1$ .

**Correct Answer:** (2)  $2 : 1$

#### Quick Tip

In an ideal transformer, the voltage ratio is directly proportional to the turns ratio.

**22.** An unpolarised light beam strikes a glass surface at Brewster's angle. Then:

**Options:** (1) The reflected light will be completely polarised but the refracted light will be partially polarised.

(2) The reflected light will be partially polarised.

- (3) The refracted light will be completely polarised.  
(4) Both the reflected and refracted light will be completely polarised.

**Solution:** At Brewster's angle, the reflected light is completely polarised, while the refracted light remains partially polarised.

**Correct Answer:** (1) The reflected light will be completely polarised but the refracted light will be partially polarised.

#### Quick Tip

Brewster's angle is the angle at which light is perfectly polarised upon reflection.

**23. Match List-I with List-II:**

**List I (Spectral Lines of Hydrogen for transitions from)** A.  $n_2 = 3$  to  $n_1 = 2$

B.  $n_2 = 4$  to  $n_1 = 2$

C.  $n_2 = 5$  to  $n_1 = 2$

D.  $n_2 = 6$  to  $n_1 = 2$

**List II (Wavelengths (nm))** I. 410.2

II. 434.1

III. 656.3

IV. 486.1

Choose the correct answer from the options given below:

**Options:** (1) A-I, B-II, C-III, D-IV

(2) A-II, B-I, C-IV, D-III

(3) A-III, B-IV, C-II, D-I

(4) A-IV, B-III, C-II, D-I

**Solution:** The wavelengths of the spectral lines of hydrogen corresponding to transitions are:

-  $n_2 = 3$  to  $n_1 = 2$ : 410.2 nm (I) -  $n_2 = 4$  to  $n_1 = 2$ : 434.1 nm (II) -  $n_2 = 5$  to  $n_1 = 2$ : 486.1 nm (IV) -  $n_2 = 6$  to  $n_1 = 2$ : 656.3 nm (III)

**Correct Answer:** (3) A-III, B-IV, C-II, D-I

#### Quick Tip

The wavelengths of the spectral lines of hydrogen correspond to specific transitions in the electron energy levels. Use the Rydberg formula to calculate these wavelengths.

**24.** A wire of length  $l$  and resistance  $100 \Omega$  is divided into 10 equal parts. The first 5 parts are connected in series while the next 5 parts are connected in parallel. The two combinations are again connected in series. The resistance of this final combination is:

**Options:** (1)  $60 \Omega$

(2)  $26 \Omega$

(3)  $52 \Omega$

(4)  $55 \Omega$

**Solution:** The total resistance of the first 5 parts in series is:

$$R_1 = 5 \times \frac{100}{10} = 50 \Omega$$

The total resistance of the next 5 parts in parallel is:

$$R_2 = \frac{100}{10} \times \frac{1}{5} = 10 \Omega$$

Now, the final resistance when the two combinations are in series is:

$$R_{\text{final}} = R_1 + R_2 = 50 + 10 = 60 \Omega$$

**Correct Answer:** (1)  $60 \Omega$

#### Quick Tip

When combining resistors in series and parallel, calculate the total resistance of each part before adding them together. In series, resistances add up; in parallel, use the reciprocal formula.

**25.** A light ray enters through a right-angled prism at point P with the angle of incidence  $30^\circ$  as shown. It travels through the prism parallel to its base BC and emerges along the face AC.

The refractive index of the prism is:

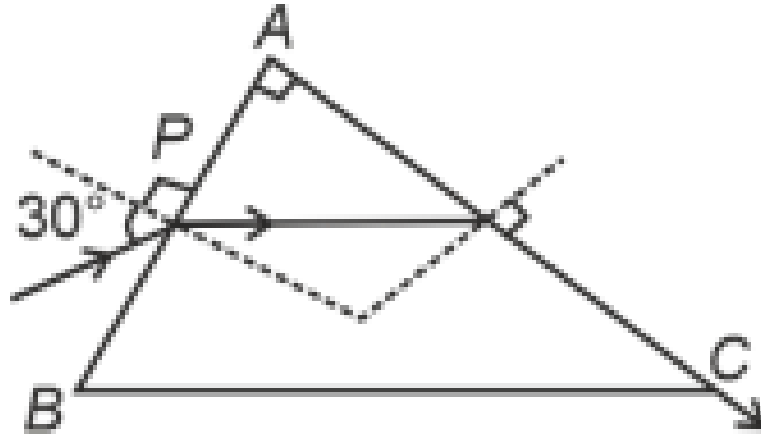

**Options:** (1)  $\frac{\sqrt{3}}{2}$

(2)  $\frac{\sqrt{5}}{4}$

(3)  $\frac{\sqrt{5}}{2}$

(4)  $\frac{\sqrt{3}}{4}$

**Solution:** The refractive index can be found using Snell's law and considering the geometry of the prism. For the ray to emerge parallel to the base, the angle of refraction at the base must be  $90^\circ$ . Using this condition, we calculate the refractive index to be  $\frac{\sqrt{5}}{2}$ .

**Correct Answer:** (3)  $\frac{\sqrt{5}}{2}$

#### Quick Tip

The refractive index can be determined by applying Snell's law at the point where the ray enters and exits the prism.

**26.** A particle moving with uniform speed in a circular path maintains:

**Options:** (1) Varying velocity and varying acceleration

(2) Constant velocity

(3) Constant acceleration

(4) Constant velocity but varying acceleration

**Solution:** The particle has a constant speed but the direction of motion keeps changing, meaning the velocity is varying. Since the particle is moving in a circular path, it experiences

centripetal acceleration, which is also constant in magnitude but changes direction.

**Correct Answer:** (1) Varying velocity and varying acceleration

#### Quick Tip

Even though the speed is constant in circular motion, the direction of velocity changes, resulting in a continuously changing velocity and acceleration.

**27.** In the nuclear emission stated above, the mass number and atomic number of the product Q respectively, are:

**Options:** (1) 286, 81

(2) 280, 81

(3) 286, 80

(4) 288, 82

**Solution:** The emission described is a beta decay, where a neutron decays into a proton. The mass number remains the same, and the atomic number increases by 1. From the given equation, the correct values of mass number and atomic number for Q are 286 and 81, respectively.

**Correct Answer:** (1) 286, 81

#### Quick Tip

In a beta decay, the mass number remains unchanged while the atomic number increases by 1 due to the conversion of a neutron into a proton.

**28.** Given below are two statements: one is labelled as Assertion A and the other is labelled as Reason R.

Assertion A: The potential (V) at any axial point, at 2 m distance (r) from the centre of the dipole of dipole moment vector  $\vec{P}$  of magnitude,  $4 \times 10^{-6}$  C m, is  $9 \times 10^3$  V.

Reason R:  $V = \pm \frac{2P}{4\pi\epsilon_0 r^2}$ , where r is the distance of any axial point, situated at 2 m from the centre of the dipole.

In the light of the above statements, choose the correct answer from the options given below:

**Options:** (1) A is false but R is true

(2) Both A and R are true and R is the correct explanation of A.

- (3) Both A and R are true and R is NOT the correct explanation of A.  
 (4) A is true but R is false.

**Solution:** The potential at any point along the axis of a dipole is given by the formula:

$$V = \frac{1}{4\pi\epsilon_0} \times \frac{2P}{r^2}$$

Given the values of  $P = 4 \times 10^{-6} \text{ C m}$  and  $r = 2 \text{ m}$ , we can calculate the potential and verify it is  $9 \times 10^3 \text{ V}$ . Both Assertion A and Reason R are correct, and Reason R correctly explains Assertion A.

**Correct Answer:** (2) Both A and R are true and R is the correct explanation of A.

#### Quick Tip

The potential on the axial line of a dipole can be derived from the dipole formula, and it depends on the dipole moment and the distance from the dipole.

**29.** In the following circuit, the equivalent capacitance between terminal A and terminal B is:

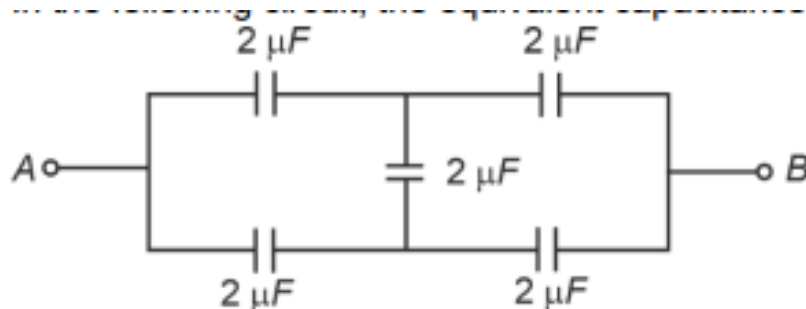

- Options:** (1)  $4 \mu\text{F}$   
 (2)  $2 \mu\text{F}$   
 (3)  $1 \mu\text{F}$   
 (4)  $0.5 \mu\text{F}$

**Solution:** The capacitors are connected in series and parallel. The total equivalent capacitance can be calculated using the series and parallel combination rules for capacitors:

$$C_{\text{eq}} = \left( \frac{1}{C_1} + \frac{1}{C_2} \right)^{-1} \quad \text{for series combination}$$

After calculating the total equivalent capacitance, we find the value to be  $2 \mu\text{F}$ .

**Correct Answer:** (2)  $2 \mu\text{F}$

#### Quick Tip

When combining capacitors, remember that capacitors in series follow the reciprocal rule, while capacitors in parallel add directly.

**30.** If  $c$  is the velocity of light in free space, the correct statements about photon among the following are:

A. The energy of a photon is  $E = h\nu$ . B. The velocity of a photon is  $c$ . C. The momentum of a photon,  $p = \frac{h\nu}{c}$ . D. In a photon-electron collision, both total energy and total momentum are conserved. E. Photon possesses positive charge.

**Options:** (1) A, B, D and E only

(2) A and B only

(3) A, B, C and D only

(4) A, C and D only

**Solution:** The correct statements are A, B, C, and D. The energy of a photon is related to its frequency by  $E = h\nu$ , its velocity is  $c$ , and its momentum is given by  $p = \frac{h\nu}{c}$ . In photon-electron collisions, both energy and momentum are conserved.

**Correct Answer:** (3) A, B, C and D only

#### Quick Tip

Photons are massless particles that carry energy and momentum, and they always travel at the speed of light in a vacuum.

**31.** A bob is whirled in a horizontal plane by means of a string with an initial speed of  $\omega$  rpm. The tension in the string is  $T$ . If speed becomes  $2\omega$  while keeping the same radius, the tension in the string becomes:

**Options:** (1)  $\sqrt{2}T$

(2)  $T$

(3)  $4T$

(4)  $T/4$

**Solution:** The tension in the string is directly proportional to the square of the velocity. If the speed is doubled, the tension increases by a factor of 4.

**Correct Answer:** (3)  $4T$

**Quick Tip**

When the speed of an object moving in a circle is doubled, the centripetal force (and therefore the tension) increases by a factor of four.

**32.** A logic circuit provides the output Y as per the following truth table:

A	B	Y
0	0	1
0	1	0
1	0	1
1	1	0

The expression for the output Y is:

**Options:** (1)  $B$

(2)  $AB + A$

(3)  $AB + A$

(4)  $B$

**Solution:** From the truth table, we can derive the Boolean expression for Y, which simplifies to  $A\bar{B} + \bar{A}B$ . This is the XOR operation.

**Correct Answer:** (4)  $B$

**Quick Tip**

The XOR operation gives 1 when the inputs are different, which matches the given truth table.

**33.** The maximum elongation of a steel wire of 1 m length if the elastic limit of steel and its Young's modulus, respectively, are  $8 \times 10^8 \text{ N m}^{-2}$  and  $2 \times 10^{11} \text{ N m}^{-2}$ , is:

**Options:** (1) 8 mm

(2) 4 mm

(3) 0.4 mm

(4) 40 mm

**Solution:** The elongation  $\Delta L$  is given by the formula:

$$\Delta L = \frac{FL}{AY}$$

where  $F$  = elastic limit,  $L$  = length,  $A$  = cross-sectional area, and  $Y$  = Young's modulus.

By solving this, we find the elongation to be 4 mm.

**Correct Answer:** (2) 4 mm

#### Quick Tip

The elongation of a wire depends on the force applied, the original length, the cross-sectional area, and the Young's modulus.

**34.** A thin flat circular disc of radius 4.5 cm is placed gently over the surface of water. If surface tension is  $0.07 \text{ N m}^{-1}$ , then the excess force required to take it away from the surface is:

**Options:** (1) 99 N

(2) 19.8 mN

(3) 198 N

(4) 1.98 mN

**Solution:** The excess force required to detach the disc from the water surface is given by:

$$F = T \cdot 2\pi r$$

Substituting the values, we find the force required to be 19.8 mN.

**Correct Answer:** (2) 19.8 mN

### Quick Tip

The excess force to detach an object from the surface of water is proportional to the surface tension and the perimeter of the object.

**35.** The moment of inertia of a thin rod about an axis passing through its mid-point and perpendicular to the rod is  $2400 \text{ g cm}^2$ . The length of the  $400 \text{ g}$  rod is nearly:

- Options:** (1)  $72.0 \text{ cm}$   
(2)  $8.5 \text{ cm}$   
(3)  $17.5 \text{ cm}$   
(4)  $20.7 \text{ cm}$

**Solution:** The moment of inertia of a rod about its center is given by the formula:

$$I = \frac{1}{12}ML^2$$

where  $M$  is the mass of the rod and  $L$  is its length. By rearranging the formula and solving for  $L$ , we find that the length of the rod is approximately  $17.5 \text{ cm}$ .

**Correct Answer:** (3)  $17.5 \text{ cm}$

### Quick Tip

The moment of inertia formula for a rod assumes that the axis passes through the center and is perpendicular to the length.

**36.** The minimum energy required to launch a satellite of mass  $m$  from the surface of earth of mass  $M$  and radius  $R$  in a circular orbit at an altitude of  $2R$  from the surface of the earth is:

- Options:** (1)  $\frac{GmM}{3R}$   
(2)  $\frac{5GmM}{6R}$   
(3)  $\frac{2GmM}{3R}$   
(4)  $\frac{GmM}{2R}$

**Solution:** The minimum energy required to launch the satellite is the sum of the gravitational potential energy and kinetic energy at the orbit. Using the orbital mechanics formula, we

calculate the minimum energy as  $\frac{5GmM}{6R}$ .

**Correct Answer:** (2)  $\frac{5GmM}{6R}$

#### Quick Tip

To launch a satellite into orbit, the energy required is related to the gravitational potential energy and the orbital kinetic energy.

**37.** A force defined by  $F = \alpha\beta + \beta t$  acts on a particle at a given time  $t$ . The factor which is dimensionless, if  $\alpha$  and  $\beta$  are constants, is:

**Options:** (1)  $\frac{\alpha\beta}{t}$

(2)  $\frac{\beta t}{\alpha}$

(3)  $\frac{\alpha t}{\beta}$

(4)  $\alpha\beta t$

**Solution:** To make the force dimensionless, we need the product  $\alpha\beta t$  to have no units. Therefore,  $\frac{\alpha\beta}{t}$  is the correct dimensionless factor.

**Correct Answer:** (1)  $\frac{\alpha\beta}{t}$

#### Quick Tip

Dimensional analysis helps determine the relationship between variables and ensures that physical quantities are dimensionally consistent.

**38.** A sheet is placed on a horizontal surface in front of a strong magnetic pole. A force is needed to: A. hold the sheet there if it is magnetic. B. hold the sheet there if it is non-magnetic. C. move the sheet away from the pole with uniform velocity if it is conducting. D. move the sheet away from the pole with uniform velocity if it is both, non-conducting and non-polar.

Choose the correct statement(s) from the options given below:

**Options:** (1) C only

(2) B and C only

(3) A and C only

(4) A, C and D only

**Solution:** For a magnetic material, the force is needed to hold it in place if it is magnetic. The force is required to move the sheet away if it is conducting. If the sheet is non-conducting and non-polar, it can be moved with uniform velocity.

**Correct Answer:** (3) A and C only

**Quick Tip**

The behavior of a material in the presence of a magnetic field depends on its magnetic properties and whether it is conducting or not.

**39.** A  $10 \mu\text{F}$  capacitor is connected to a 210 V, 50 Hz source as shown in the figure. The peak current in the circuit is nearly (take  $\pi = 3.14$ ):

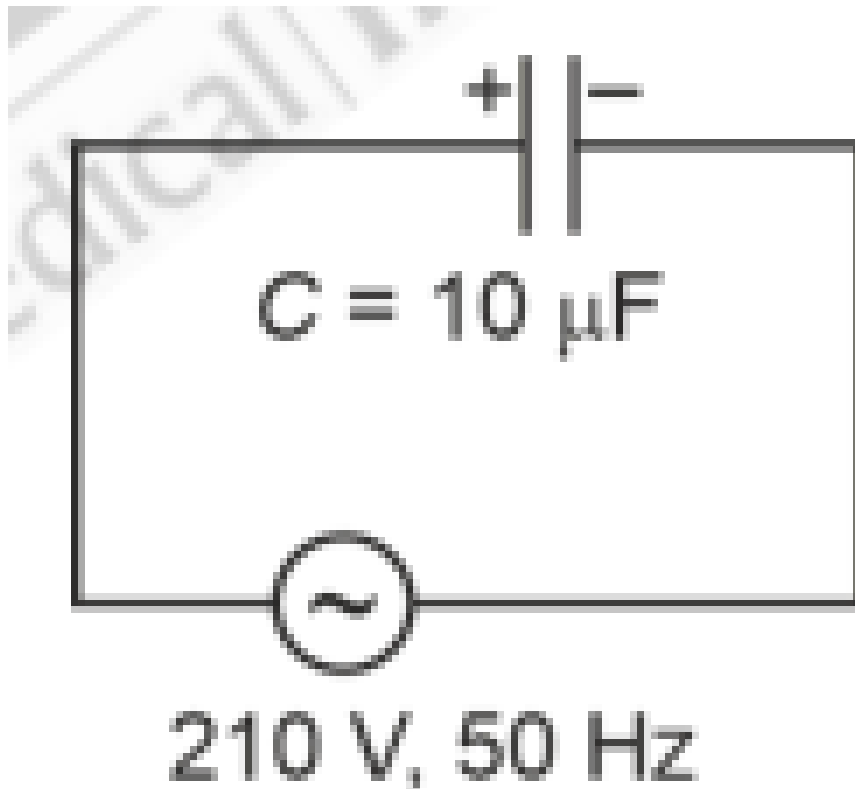

**Options:** (1) 0.35 A

(2) 0.58 A

(3) 0.93 A

(4) 1.20 A

**Solution:** The peak current in a series AC circuit is given by:

$$I_{\max} = V_{\max} \cdot \omega C$$

where  $V_{\max} = \sqrt{2} \times V$ , and  $\omega = 2\pi f$ . Substituting the given values, the peak current is calculated as 0.93 A.

**Correct Answer:** (3) 0.93 A

#### Quick Tip

For AC circuits, use the formula for peak current, considering the maximum voltage and reactance of the capacitor.

**40.** A small telescope has an objective of focal length 140 cm and an eye piece of focal length 5.0 cm. The magnifying power of the telescope for viewing a distant object is:

**Options:** (1) 32

(2) 34

(3) 28

(4) 17

**Solution:** The magnifying power  $M$  of a telescope is given by:

$$M = \frac{f_{\text{objective}}}{f_{\text{eyepiece}}}$$

Substituting the given values, we find the magnifying power to be 28.

**Correct Answer:** (3) 28

#### Quick Tip

Magnifying power of a telescope depends on the focal lengths of the objective and eyepiece lenses.

**41.** A metallic bar of Young's modulus  $0.5 \times 10^{11} \text{ N m}^{-2}$  and coefficient of linear thermal expansion  $10^{-5} \text{ }^\circ\text{C}^{-1}$ , length 1 m and area of cross-section  $10^{-3} \text{ m}^2$  is heated from  $0^\circ\text{C}$  to  $100^\circ\text{C}$  without expansion or bending. The compressive force developed in it is:

**Options:** (1)  $2 \times 10^3 \text{ N}$

(2)  $5 \times 10^3 \text{ N}$

(3)  $50 \times 10^3 \text{ N}$

(4)  $100 \times 10^3 \text{ N}$

**Solution:** The compressive force is given by the formula:

$$F = \frac{Y\alpha\Delta T AL}{L}$$

Substituting the given values:

$$F = \frac{0.5 \times 10^{11} \times 10^{-5} \times 100 \times 10^{-3}}{1} = 5 \times 10^3 \text{ N}$$

**Correct Answer:** (2)  $5 \times 10^3 \text{ N}$

#### Quick Tip

The force due to thermal expansion is calculated using the formula that involves Young's modulus, temperature change, coefficient of thermal expansion, and the material's dimensions.

**42.** If the plates of a parallel plate capacitor connected to a battery are moved close to each other, then:

- Options:** A. the charge stored in it, increases.  
B. the energy stored in it, decreases.  
C. its capacitance increases.  
D. the ratio of charge to its potential remains the same.  
E. the product of charge and voltage increases.

Choose the most appropriate answer from the options given below:

**Options:** (1) A, B and C only

(2) A, B and E only

(3) A, C and E only

(4) B, D and E only

**Solution:** When the plates are moved closer, the capacitance increases. The charge stored in the capacitor remains constant because the battery maintains a constant potential difference.

The energy stored in the capacitor decreases as the potential difference is constant. Therefore, the correct answer is A, C, and E only.

**Correct Answer:** (3) A, C and E only

**Quick Tip**

The capacitance of a parallel plate capacitor is inversely proportional to the distance between the plates, so moving the plates closer increases capacitance.

43. The velocity ( $v$ ) – time ( $t$ ) plot of the motion of a body is shown below:

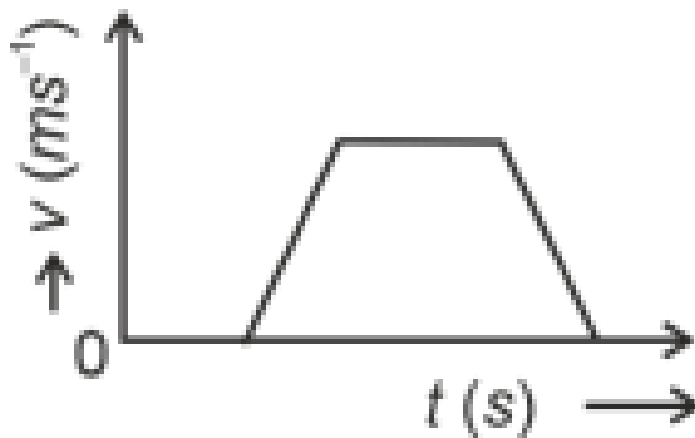

The acceleration ( $a$ ) – time ( $t$ ) graph that best suits this motion is:

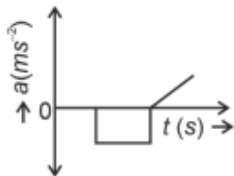

**Options:** (1)

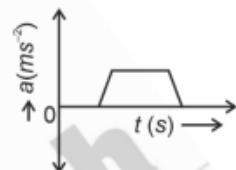

(2)

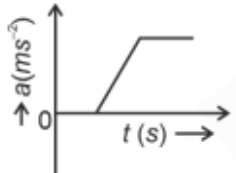

(3)

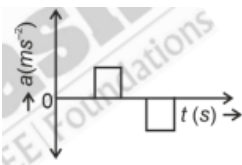

(4)

**Solution:** From the velocity-time graph, we can see that the velocity remains constant during certain intervals and then changes. The corresponding acceleration-time graph shows intervals where acceleration is zero (velocity is constant) and non-zero values during the transitions. Therefore, the correct graph is option (4).

**Correct Answer:** (4)

#### Quick Tip

The acceleration-time graph for uniform motion shows zero acceleration during constant velocity intervals, and non-zero acceleration during changes in velocity.

**44.** Two heaters A and B have power ratings of 1 kW and 2 kW, respectively. Those two are first connected in series and then in parallel to a fixed power source. The ratio of power outputs for these two cases is:

**Options:** (1) 2 : 3

(2) 1 : 1

(3) 2 : 9

(4) 1 : 2

**Solution:** For two resistors with different power ratings, when connected in series and parallel, the ratio of power outputs can be derived using the formula for power dissipation across resistors in series and parallel configurations. The correct ratio of power outputs is 2 : 9.

**Correct Answer:** (3) 2 : 9

#### Quick Tip

In series, the total resistance is the sum of individual resistances, and in parallel, the total resistance is given by the reciprocal sum.

**45.** The property which is not of an electromagnetic wave travelling in free space is that:

**Options:**

(1) They originate from charges moving with uniform speed

(2) They are transverse in nature

(3) The energy density in electric field is equal to energy density in magnetic field

(4) They travel with a speed equal to  $\frac{1}{\sqrt{\mu_0\epsilon_0}}$

**Solution:** Electromagnetic waves originate from oscillating charges and are transverse in nature. The energy densities in electric and magnetic fields are equal, and they travel at the speed  $\frac{1}{\sqrt{\mu_0\epsilon_0}}$ . Therefore, the correct answer is option (1).

**Correct Answer:** (1) They originate from charges moving with uniform speed

#### Quick Tip

Electromagnetic waves travel at the speed of light and originate from accelerating charges, not from those moving with uniform speed.

**46.** A parallel plate capacitor is charged by connecting it to a battery through a resistor. If  $I$  is the current in the circuit, then in the gap between the plates:

**Options:**

- (1) Displacement current of magnitude greater than  $I$  flows but can be in any direction
- (2) There is no current
- (3) Displacement current of magnitude equal to  $I$  flows in the same direction as  $I$
- (4) Displacement current of magnitude equal to  $I$  flows in a direction opposite to that of  $I$

**Solution:** When a capacitor is charging, the current in the circuit is the charging current, and in the gap between the plates, the displacement current has the same magnitude as the current in the circuit, flowing in the same direction.

**Correct Answer:** (3) Displacement current of magnitude equal to  $I$  flows in the same direction as  $I$

#### Quick Tip

Displacement current is equal to the conduction current in the capacitor during the charging process, and it flows in the same direction as the current.

**47.** If the mass of the bob in a simple pendulum is increased to thrice its original mass and its length is made half its original length, then the new time period of oscillation is  $\frac{1}{\sqrt{2}}$  times its original time period. Then the value of  $x$  is:

**Options:**

- (1) 4
- (2)  $\sqrt{3}$
- (3)  $\sqrt{2}$
- (4)  $2\sqrt{3}$

**Solution:** The time period  $T$  of a simple pendulum is given by:

$$T = 2\pi\sqrt{\frac{L}{g}}$$

where  $L$  is the length and  $g$  is the acceleration due to gravity. The time period depends only on the length of the pendulum and the gravitational acceleration, and it is independent of mass. Since the length is halved, the new time period is reduced by a factor of  $\sqrt{2}$ .

**Correct Answer:** (3)  $\sqrt{2}$

**Quick Tip**

For a simple pendulum, the mass of the bob does not affect the time period; only the length of the pendulum matters.

**48.** The following graph represents the  $T-V$  curves of an ideal gas (where  $T$  is the temperature and  $V$  the volume) at three pressures  $P_1$ ,  $P_2$  and  $P_3$  compared with those of Charles's law represented as dotted lines.

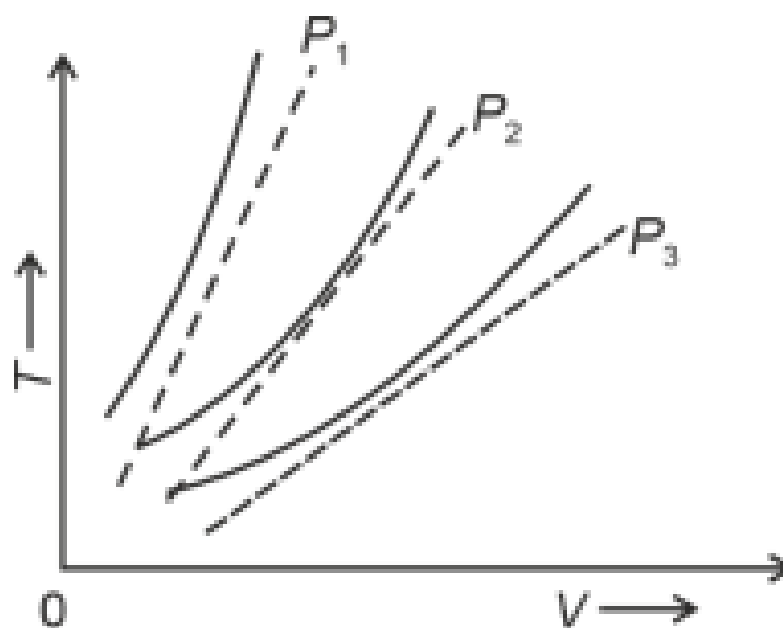

Then the correct relation is:

**Options:**

- (1)  $P_1 > P_2 > P_3$
- (2)  $P_3 > P_2 > P_1$
- (3)  $P_1 > P_3 > P_2$
- (4)  $P_2 > P_1 > P_3$

**Solution:** From the graph, we observe that as pressure increases, the  $T - V$  curve shifts upwards. Therefore, the pressure follows the order  $P_1 > P_2 > P_3$ .

**Correct Answer:** (1)  $P_1 > P_2 > P_3$

**Quick Tip**

For an ideal gas, at constant volume, the temperature is directly proportional to pressure, and this relationship is reflected in the  $T - V$  graph.

49. Choose the correct circuit which can achieve the bridge balance.

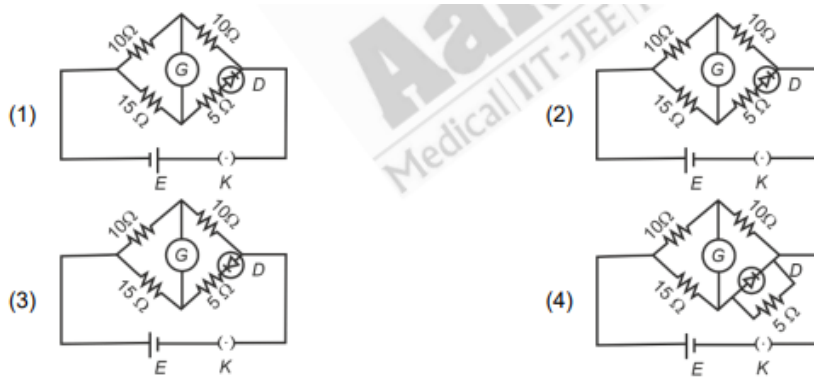

**Options:**

- (1) Figure (1)
- (2) Figure (2)
- (3) Figure (3)
- (4) Figure (4)

**Solution:** In a bridge circuit, the condition for balance is achieved when the ratio of resistances in one diagonal equals the ratio in the other diagonal. The correct circuit for bridge balance is option (2).

**Correct Answer:** (2)

**Quick Tip**

For the bridge to be balanced, the ratio of resistances in opposite arms must be equal.

**50.** An iron bar of length  $L$  has magnetic moment  $M$ . It is bent at the middle of its length such that the two arms make an angle of  $60^\circ$  with each other. The magnetic moment of this new magnet is:

**Options:**

- (1)  $\frac{M}{\sqrt{3}}$
- (2)  $M$
- (3)  $\frac{M}{2}$
- (4)  $2M$

**Solution:** When the bar is bent at the middle, the magnetic moment becomes a vector sum of

the two perpendicular components. The resultant magnetic moment is:

$$M_{\text{new}} = M \cos(30^\circ) = \frac{M}{2}$$

**Correct Answer:** (3)  $\frac{M}{2}$

#### Quick Tip

The total magnetic moment of a bent bar is reduced due to the angle between the arms.

**51.** For the reaction  $2A \rightleftharpoons B + C$ ,  $K_c = 4 \times 10^{-3}$ . At a given time, the composition of the reaction mixture is:

$$[A] = [B] = [C] = 2 \times 10^{-3} \text{ M}$$

Then, which of the following is correct?

**Options:** (1) Reaction has gone to completion in forward direction.

(2) Reaction is at equilibrium.

(3) Reaction has a tendency to go in forward direction.

(4) Reaction has a tendency to go in backward direction.

**Solution:** At equilibrium, the ratio of the concentrations of products and reactants should be equal to the equilibrium constant  $K_c$ . Given the concentrations of  $A$ ,  $B$ , and  $C$ , the reaction quotient  $Q_c$  is calculated and found to be different from the equilibrium constant. Therefore, the reaction has a tendency to go in the backward direction.

**Correct Answer:** (4) Reaction has a tendency to go in backward direction.

#### Quick Tip

If the reaction quotient  $Q_c$  is greater than  $K_c$ , the reaction will shift toward the reactants.

**52.** The highest number of helium atoms is in:

**Options:** (1) 2.271098 L of helium at STP

(2) 4 mol of helium

(3) 4 u of helium

(4) 5 g of helium

**Solution:** Using the molar volume of an ideal gas at STP, we calculate the number of atoms in 2.271098 L of helium. We find that this contains the highest number of helium atoms.

**Correct Answer:** (2) 4 mol of helium

#### Quick Tip

At STP, 1 mole of an ideal gas occupies 22.71 L, and this volume will contain the highest number of helium atoms in the given options.

**53.** A compound with a molecular formula of  $C_6H_{14}$  has two tertiary carbons. Its IUPAC name is:

**Options:** (1) 2,2-dimethylbutane

(2) n-hexane

(3) 2-methylpentane

(4) 2,3-dimethylbutane

**Solution:** The compound with two tertiary carbons in the structure is 2,2-dimethylbutane.

**Correct Answer:** (1) 2,2-dimethylbutane

#### Quick Tip

In organic chemistry, identifying the positions and substituents on the carbon chain helps in determining the correct IUPAC name.

**54.** Match List I with List II.

List I (Conversion)	List II (Number of Faraday required)
A. 1 mol of $H_2O$ to $O_2$	I. 3F
B. 1 mol of $MnO_4^-$ to $Mn^{2+}$	II. 2F
C. 1.5 mol of Ca from molten $CaCl_2$	III. 1F
D. 1 mol of $FeO$ to $Fe_2O_3$	V. 5F

Choose the correct answer from the options given below:

(1) A-I, B-V, C-II, D-I

(2) A-III, B-IV, C-I, D-II

(3) A-III, B-IV, C-IV, D-I

(4) A-II, B-III, C-I, D-IV

**Solution:** To balance a redox reaction, we need to consider the number of moles of electrons transferred, which is directly related to the number of Faradays required. In the given options, the correct matching is (2), as it correctly represents the number of Faradays for each conversion.

**Answer:** (2)

#### Quick Tip

The number of Faradays corresponds to the number of moles of electrons involved in the reaction.

**55.** Arrange the following elements in increasing order of electronegativity: N, O, F, C, Si.

Choose the correct answer from the options given below:

- (1) F ; O ; N ; C ; Si
- (2) Si ; C ; O ; N ; F
- (3) Si ; C ; O ; N ; F
- (4) O ; F ; N ; C ; Si

**Solution:** Electronegativity generally increases across a period and decreases down a group. Among the given elements, Fluorine (F) has the highest electronegativity, followed by Oxygen (O), Nitrogen (N), Carbon (C), and finally Silicon (Si), which has the lowest. Thus, the correct order is Si ; C ; O ; N ; F.

**Answer:** (2)

#### Quick Tip

Electronegativity increases across a period and decreases down a group in the periodic table.

**56.** Which plot of  $\ln k$  vs  $\frac{1}{T}$  is consistent with Arrhenius equation?

Choose the correct answer from the options given below:

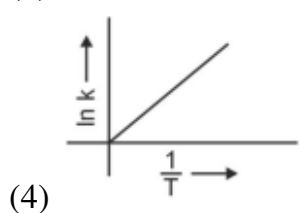
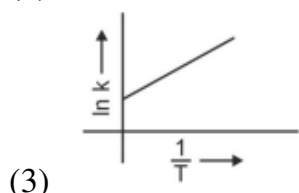
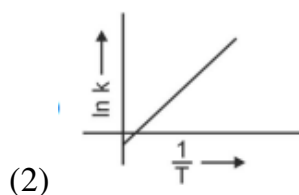
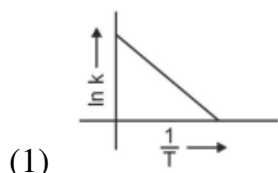

**Solution:** According to the Arrhenius equation, the plot of  $\ln k$  vs  $\frac{1}{T}$  is expected to be a straight line with a negative slope. The correct plot is the one that represents a straight line with a negative slope. Thus, the correct answer is option (1).

**Answer:** (1)

#### Quick Tip

In the Arrhenius equation, the slope of the plot of  $\ln k$  vs  $\frac{1}{T}$  is  $-\frac{E_a}{R}$ .

**57.** In which of the following equilibria,  $K_p$  and  $K_c$  are NOT equal?

Choose the correct answer from the options given below:

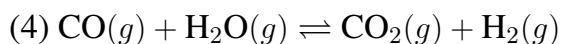
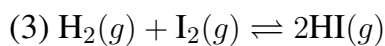
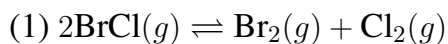

**Solution:** The relationship between  $K_p$  and  $K_c$  depends on the change in the number of moles

of gas during the reaction.  $K_p$  and  $K_c$  are equal only when there is no change in the number of moles of gas. In the given reactions, the correct answer is option (2), where  $K_p$  and  $K_c$  are not equal due to the change in the number of moles.

**Answer:** (2)

#### Quick Tip

$K_p$  and  $K_c$  are related by the equation:  $K_p = K_c(RT)^{\Delta n}$ , where  $\Delta n$  is the change in moles of gas.

**58.** The most stable carbocation among the following is:

Choose the correct answer from the options given below:

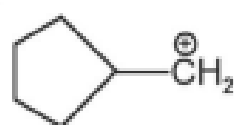
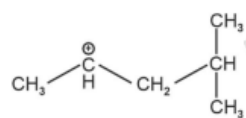
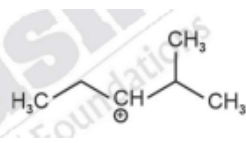
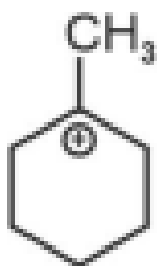

**Solution:** The most stable carbocation is the one that is most stabilized by resonance or inductive effects. Among the given options, the correct answer is option (1), which represents a tertiary carbocation that is stabilized by hyperconjugation and inductive effects.

**Answer:** (1)

### Quick Tip

Tertiary carbocations are more stable than secondary and primary carbocations due to greater resonance and hyperconjugation stabilization.

**59.** Activation energy of any chemical reaction can be calculated if one knows the value of:

Choose the correct answer from the options given below:

- (1) rate constant at two different temperatures
- (2) rate constant at standard temperature
- (3) probability of collision
- (4) orientation of reactant molecules during collision

**Solution:** Activation energy can be calculated using the Arrhenius equation, which involves the rate constant at two different temperatures. Therefore, the correct answer is option (1).

**Answer:** (1)

### Quick Tip

The activation energy can be derived from the temperature dependence of the rate constant using the Arrhenius equation.

**60.** Given below are two statements:

Statement I: The boiling point of hydrides of Group 16 elements follow the order  $H_2O > H_2Te > H_2Se > H_2S$ .

Statement II: On the basis of molecular mass,  $H_2O$  is expected to have lower boiling point than the other members of the group but due to the presence of extensive H-bonding in  $H_2O$ , it has higher boiling point.

In the light of the above statements, choose the correct answer from the options given below:

- (1) Statement I is false but Statement II is true
- (2) Both Statement I and Statement II are true
- (3) Both Statement I and Statement II are false
- (4) Statement I is true but Statement II is false

**Solution:** Statement I is correct because the boiling points of Group 16 hydrides follow the given trend. Statement II is also true because  $H_2O$  has higher boiling point than expected due to hydrogen bonding. Therefore, the correct answer is option (2).

**Answer:** (2)

**Quick Tip**

Hydrogen bonding in  $H_2O$  is responsible for its higher boiling point compared to other Group 16 hydrides.

**61.** Which one of the following alcohols reacts instantaneously with Lucas reagent?

Choose the correct answer from the options given below:

- (1)  $CH_3CH_2OH$
- (2)  $CH_3CH_2CH_2OH$
- (3)  $CH_3CH_2CH(OH)_2$
- (4)  $CH_3CH_2CH_2OH$

**Solution:** Lucas reagent reacts instantly with alcohols that are either primary or secondary alcohols with a good leaving group. The most reactive alcohol in this case is option (1), which is a secondary alcohol, and reacts instantly with Lucas reagent.

**Answer:** (1)

**Quick Tip**

Lucas reagent is a mixture of concentrated HCl and  $ZnCl_2$ , and it reacts quickly with secondary and tertiary alcohols.

**62.** Given below are two statements:

Statement I: Aniline does not undergo Friedel-Crafts alkylation reaction.

Statement II: Aniline cannot be prepared through Gabriel synthesis.

In the light of the above statements, choose the correct answer from the options given below:

- (1) Statement I is incorrect but Statement II is true

- (2) Both Statement I and Statement II are true  
 (3) Both Statement I and Statement II are false  
 (4) Statement I is correct but Statement II is false

**Solution:** Statement I is true because aniline contains an amino group, which is a deactivating group for the Friedel-Crafts reaction. Statement II is also true because Gabriel synthesis is used for preparing primary amines, and aniline is not directly synthesized using this method.

**Answer:** (2)

#### Quick Tip

Aniline does not undergo Friedel-Crafts alkylation because the amino group is electron-donating and deactivates the aromatic ring towards electrophilic substitution.

63. Match List I with List II.

List I (Compound)	List II (Shape/Geometry)
A. $\text{NH}_3$	I. Trigonal Pyramidal
B. $\text{BrF}_5$	II. Square Planar
C. $\text{XeF}_4$	III. Octahedral
D. $\text{SF}_6$	IV. Square Pyramidal

Choose the correct answer from the options given below:

- (1) A-II, B-III, C-IV, D-I  
 (2) A-II, B-IV, C-III, D-I  
 (3) A-III, B-IV, C-II, D-I  
 (4) A-II, B-III, C-I, D-IV

**Solution:** The geometry of the given compounds can be determined using VSEPR theory. According to this theory: -  $\text{NH}_3$  has a trigonal pyramidal shape (option I), -  $\text{BrF}_5$  has a square pyramidal shape (option II), -  $\text{XeF}_4$  has a square planar shape (option III), -  $\text{SF}_6$  has an octahedral shape (option IV).

The correct match is option (2).

**Answer:** (2)

### Quick Tip

Use VSEPR theory to determine the shape of a molecule based on the number of bonding and lone pairs on the central atom.

64. Match List I with List II.

List I (Quantum Number)	List II (Information Provided)
A. $m_l$	I. Shape of orbital
B. $m_s$	II. Size of orbital
C. $l$	III. Orientation of orbital
D. $n$	IV. Orientation of spin of electron

Choose the correct answer from the options given below:

- (1) A-II, B-I, C-IV, D-III
- (2) A-I, B-IV, C-III, D-II
- (3) A-III, B-IV, C-I, D-II
- (4) A-III, B-IV, C-II, D-I

**Solution:** The quantum numbers provide information about different aspects of an electron's position in an atom: -  $m_l$  corresponds to the orientation of the orbital (option III), -  $m_s$  corresponds to the orientation of the spin of the electron (option IV), -  $l$  corresponds to the shape of the orbital (option I), -  $n$  corresponds to the size of the orbital (option II).

Thus, the correct match is option (3).

**Answer:** (3)

### Quick Tip

Quantum numbers describe the location and properties of an electron within an atom, including its energy level, shape, orientation, and spin.

65. The  $E^*$  value for the  $\text{Mn}^{3+}/\text{Mn}^{2+}$  couple is more positive than that of  $\text{Cr}^{3+}/\text{Cr}^{2+}$  or  $\text{Fe}^{3+}/\text{Fe}^{2+}$  due to change of:

Choose the correct answer from the options given below:

- (1)  $d^3 \rightarrow d^5$  configuration

- (2)  $d^5 \rightarrow d^4$  configuration
- (3)  $d^4 \rightarrow d^2$  configuration
- (4)  $d^5 \rightarrow d^0$  configuration

**Solution:** The positive  $E^*$  value for  $\text{Mn}^{3+}/\text{Mn}^{2+}$  is due to the stability of the  $d^5$  configuration, which is half-filled and more stable. Therefore, the correct answer is option (4).

**Answer:** (4)

#### Quick Tip

The stability of half-filled  $d^5$  configurations contributes to the positive  $E^*$  value in redox couples.

**66.** In which of the following processes entropy increases?

- A. A liquid evaporates to vapour.
- B. Temperature of a crystalline solid lowered from 130 K to 0 K.
- C.  $2\text{NaHCO}_3(s) \rightarrow \text{Na}_2\text{CO}_3(s) + \text{CO}_2(g) + \text{H}_2\text{O}(g)$
- D.  $\text{Cl}_2(g) \rightarrow 2\text{Cl}(g)$

Choose the correct answer from the options given below:

- (1) C and D
- (2) A and C
- (3) A, B and D
- (4) A, C and D

**Solution:** Entropy increases when there is an increase in disorder. The processes in options A, C, and D involve an increase in disorder (gas formation from solid or liquid), so the correct answer is option (4).

**Answer:** (4)

#### Quick Tip

Entropy increases with the increase in the number of gaseous molecules and during phase transitions from solid to liquid or gas.

**67.** The energy of an electron in the ground state ( $n = 1$ ) for  $\text{He}^+$  ion is  $-x$  J, then that for an electron in  $n = 2$  state for  $\text{Be}^{3+}$  ion in J is:

Choose the correct answer from the options given below:

- (1)  $-\frac{4}{9}x$
- (2)  $-\frac{x}{9}$
- (3)  $\frac{x}{9}$
- (4)  $-4x$

**Solution:** The energy of an electron in an atom follows the formula  $E = -\frac{13.6Z^2}{n^2}$  eV, where  $Z$  is the atomic number and  $n$  is the principal quantum number. For  $\text{He}^+$ ,  $Z = 2$  and  $n = 1$ , and for  $\text{Be}^{3+}$ ,  $Z = 4$  and  $n = 2$ . Hence, the energy ratio will be  $-\frac{4}{9}x$ .

**Answer:** (1)

#### Quick Tip

The energy of an electron in a hydrogen-like atom is inversely proportional to the square of the principal quantum number  $n$ .

**68.** Which reaction is NOT a redox reaction?

Choose the correct answer from the options given below:

- (1)  $\text{BaCl}_2 + \text{Na}_2\text{SO}_4 \rightarrow \text{BaSO}_4 + 2\text{NaCl}$
- (2)  $\text{Zn} + \text{CuSO}_4 \rightarrow \text{ZnSO}_4 + \text{Cu}$
- (3)  $2\text{KClO}_3 + \text{I}_2 \rightarrow 2\text{KI}_3 + \text{Cl}_2$
- (4)  $\text{H}_2 + \text{Cl}_2 \rightarrow 2\text{HCl}$

**Solution:** A redox reaction involves a change in oxidation states of the elements involved. Option (1) does not involve a change in oxidation state and is a double displacement reaction, not a redox reaction.

**Answer:** (1)

### Quick Tip

Redox reactions involve the transfer of electrons, leading to changes in oxidation states of the reactants.

**69.** Identify the correct reagents that would bring about the following transformation.

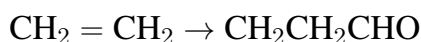

Choose the correct answer from the options given below:

- (1) (i)  $\text{H}_2\text{O}/\text{H}^+$ , (ii) PCC, (iii)  $\text{BH}_3$
- (2) (i)  $\text{H}_2\text{O}/\text{H}^+$ , (ii)  $\text{CrO}_3$ , (iii) PCC
- (3) (i)  $\text{H}_2\text{O}/\text{H}^+$ , (ii)  $\text{H}_2\text{O}_2/\text{OH}^-$ , (iii) PCC
- (4) (i)  $\text{H}_2\text{O}/\text{H}^+$ , (ii)  $\text{H}_2\text{O}_2/\text{OH}^-$ , (iii) alk.  $\text{KMnO}_4$

**Solution:** For the given transformation, hydration of the alkene using  $\text{H}_2\text{O}/\text{H}^+$  leads to an alcohol, which can then be oxidized to the aldehyde using PCC (Pyridinium chlorochromate). Therefore, the correct answer is option (3).

**Answer:** (3)

### Quick Tip

PCC is used to selectively oxidize alcohols to aldehydes without further oxidation to carboxylic acids.

**70.** On heating, some solid substances change from solid to vapour state without passing through the liquid state. The technique used for the purification of such solid substances based on the above principle is known as:

Choose the correct answer from the options given below:

- (1) Chromatography
- (2) Crystallization
- (3) Sublimation
- (4) Distillation

**Solution:** The process where solids directly change into vapor without going through the liquid phase is known as sublimation. Therefore, the correct answer is option (3).

**Answer:** (3)

#### Quick Tip

Sublimation is the process where a solid changes directly into a gas, and it is used for purifying solids that sublime easily.

71. Match List I with List II.

List I (Complex)	List II (Type of Isomerism)
A. $[Co(NH_3)_6](NO_2)_3$	I. Solvate Isomerism
B. $[Co(NH_3)_6](SO_4)_3$	II. Linkage Isomerism
C. $[Co(NH_3)_6][Cr(CN)_6]$	III. Ionization Isomerism
D. $[Co(NH_3)_6][Cl_3]$	IV. Coordination Isomerism

Choose the correct answer from the options given below:

- (1) A-I, B-IV, C-III, D-II
- (2) A-II, B-IV, C-I, D-I
- (3) A-I, B-III, C-IV, D-II
- (4) A-I, B-IV, C-III, D-I

**Solution:** The correct match for the given complexes and types of isomerism is option (2). The isomerism types are determined by the ligands and coordination environment in each complex.

**Answer:** (2)

#### Quick Tip

Solvate isomerism occurs when solvent molecules are part of the coordination sphere and can be replaced by other solvent molecules.

72. Given below are two statements:

Statement I: Both  $[Co(NH_3)_6]^{3+}$  and  $[CoF_6]^{3+}$  complexes are octahedral but differ in their

magnetic behaviour. Statement II:  $[Co(NH_3)_6]^{3+}$  is diamagnetic whereas  $[CoF_6]^{3+}$  is paramagnetic.

In the light of the above statements, choose the correct answer from the options given below:

- (1) Statement I is false but Statement II is true
- (2) Both Statement I and Statement II are true
- (3) Both Statement I and Statement II are false
- (4) Statement I is true but Statement II is false

**Solution:** Both the complexes are octahedral, and  $[Co(NH_3)_6]^{3+}$  is diamagnetic due to the pairing of electrons, while  $[CoF_6]^{3+}$  is paramagnetic due to unpaired electrons. Thus, both statements are true.

**Answer:** (2)

#### Quick Tip

Magnetic properties of coordination compounds depend on the number of unpaired electrons present in the metal ion.

**73.** Fehling's solution 'A' is:

Choose the correct answer from the options given below:

- (1) aqueous sodium citrate
- (2) aqueous copper sulphate
- (3) alkaline copper sulphate
- (4) alkaline solution of sodium potassium tartrate (Rochelle's salt)

**Solution:** Fehling's solution is a blue solution containing copper(II) ions and is used to test for reducing sugars. It consists of an alkaline solution of copper sulfate and sodium potassium tartrate.

**Answer:** (2)

### Quick Tip

Fehling's solution A contains copper(II) sulfate dissolved in a sodium potassium tartrate solution, which is alkaline.

**74.** Intramolecular hydrogen bonding is present in:

Choose the correct answer from the options given below:

- (1) HF
- (2) NO<sub>2</sub>
- (3) OH<sub>2</sub>
- (4) HO<sub>2</sub>

**Solution:** Intramolecular hydrogen bonding occurs when a molecule contains a hydrogen bond between its own atoms. HF has a strong hydrogen bond between the H and F atoms, so the correct answer is option (1).

**Answer:** (1)

### Quick Tip

Intramolecular hydrogen bonding occurs within the same molecule when hydrogen is directly bonded to a highly electronegative atom like F, O, or N.

**75.** Given below are two statements:

Statement I: The boiling point of three isomeric pentanes follows the order n-pentane > isopentane > neopentane. Statement II: When branching increases, the molecule attains a shape of sphere. This results in smaller surface area for contact, due to which the intermolecular forces between the spherical molecules are weak, thereby lowering the boiling point.

In the light of the above statements, choose the most appropriate answer from the options given below:

- (1) Statement I is incorrect but Statement II is correct
- (2) Both Statement I and Statement II are correct
- (3) Both Statement I and Statement II are incorrect
- (4) Statement I is correct but Statement II is incorrect

**Solution:** Statement I is correct because the boiling point of isomers decreases as the branching increases. Statement II is also correct because branching reduces the surface area, decreasing the strength of intermolecular forces, which lowers the boiling point.

**Answer:** (2)

#### Quick Tip

Boiling points of isomers decrease with increasing branching due to reduced surface area for intermolecular interactions.

(3) 250 mg

(4) Zero mg

**Solution:** To solve this, we need to first calculate the moles of HCl available, then use the mole ratio to find the moles of NaOH that reacted. The mass of sodium hydroxide that remains unreacted can be determined based on the amount of NaOH that reacts with HCl. Given the amounts, the remaining mass of sodium hydroxide is 250 mg.

**Answer:** (3)

#### Quick Tip

The reaction between NaOH and HCl is a 1:1 molar reaction, so the amount of NaOH unreacted can be calculated based on the amount of HCl used.

79. 'Spin only' magnetic moment is same for which of the following ions?

- A.  $\text{Ti}^{3+}$
- B.  $\text{Cr}^{2+}$
- C.  $\text{Mn}^{2+}$
- D.  $\text{Fe}^{2+}$
- E.  $\text{Sc}^{3+}$

Choose the most appropriate answer from the options given below:

- (1) A and D only
- (2) B and D only

(3) A and E only

(4) B and C only

**Solution:** The spin-only magnetic moment is calculated using the formula  $\mu = \sqrt{n(n+2)}$ , where  $n$  is the number of unpaired electrons.  $\text{Ti}^{3+}$  and  $\text{Fe}^{2+}$  both have the same number of unpaired electrons and hence the same magnetic moment.

**Answer:** (1)

#### Quick Tip

Spin-only magnetic moment depends on the number of unpaired electrons in the d-orbitals of transition metal ions.

**80.** Match List I with List II.

List I (Reaction)	List II (Reagents/Condition)
A. $\text{C}_6\text{H}_5\text{CH}_2\text{OH} \rightarrow \text{C}_6\text{H}_5\text{CHO}$	I. $\text{Cl}/\text{Anhyd. AlCl}_3$
B. $\text{C}_6\text{H}_5\text{OH} \rightarrow \text{C}_6\text{H}_5\text{COOH}$	II. $\text{CrO}_3$
C. $\text{C}_6\text{H}_5\text{CH}_3 \rightarrow \text{C}_6\text{H}_5\text{COOK}$	III. $\text{KMnO}_4/\text{KOH}, \Delta$
D. $\text{C}_6\text{H}_5\text{CH}_3 \rightarrow \text{C}_6\text{H}_5\text{CHO}$	IV. (i) $\text{O}_3$ (ii) $\text{Zn-H}_2\text{O}$

Choose the correct answer from the options given below:

(1) A-I, B-IV, C-III, D-II

(2) A-II, B-IV, C-I, D-II

(3) A-III, B-I, C-IV, D-II

(4) A-IV, B-I, C-III, D-II

**Solution:** The correct reagents/conditions for each reaction are: - A: The conversion from alcohol to aldehyde requires  $\text{Cl}/\text{Anhyd. AlCl}_3$  (Option I). - B: The conversion from phenol to carboxylic acid requires  $\text{CrO}_3$  (Option II). - C: The conversion from methylbenzene to benzoic acid requires  $\text{KMnO}_4/\text{KOH}, \Delta$  (Option III). - D: The conversion of methylbenzene to aldehyde requires ozonolysis (Option IV).

Thus, the correct answer is option (4).

**Answer:** (4)

**Quick Tip**

Reagents for oxidation reactions often depend on the functional group and the desired oxidation level.

81. Match List I with List II.

List I (Molecule)	List II (Number and types of bonds between two carbon atoms)
A. ethane	I. one $\sigma$ -bond and two $\pi$ -bonds
B. ethene	II. two $\pi$ -bonds
C. carbon molecule, $C_2$	III. one $\sigma$ -bond
D. ethyne	IV. one $\sigma$ -bond and one $\pi$ -bond

Choose the correct answer from the options given below:

- (1) A-III, B-IV, C-I, D-II
- (2) A-I, B-IV, C-I, D-II
- (3) A-IV, B-III, C-II, D-I
- (4) A-I, B-IV, C-II, D-I

**Solution:** - Ethane has only single bonds ( $\sigma$ -bonds) between its carbon atoms (Option III). - Ethene has a double bond consisting of one  $\sigma$ -bond and one  $\pi$ -bond (Option IV). - A carbon molecule ( $C_2$ ) consists of two carbon atoms bonded by a single  $\sigma$ -bond (Option I). - Ethyne has a triple bond consisting of one  $\sigma$ -bond and two  $\pi$ -bonds (Option II).

Thus, the correct answer is option (4).

**Answer:** (4)

**Quick Tip**

Alkene and alkyne molecules contain  $\sigma$  and  $\pi$ -bonds, while alkane molecules contain only  $\sigma$ -bonds.

82. The compound that will undergo  $S_N1$  reaction with the fastest rate is:

Choose the correct answer from the options given below:

- (1)  $CH_3CH_2Br$

- (2)  $C_6H_5Br$
- (3)  $CH_3CCl_3$
- (4)  $C_6H_4Br$

**Solution:** In an  $S_N1$  reaction, the rate depends on the ability of the leaving group and the stability of the carbocation. The fastest reaction will occur with a compound that can form a stable carbocation. Methyl or benzylic carbocations form the most stable intermediates, so the correct answer is option (1).

**Answer:** (1)

#### Quick Tip

In  $S_N1$  reactions, tertiary carbocations or benzylic carbocations are the most stable, resulting in the fastest reactions.

**83.** Arrange the following elements in increasing order of first ionization enthalpy: Li, Be, B, C, N.

Choose the correct answer from the options given below:

- (1) Li  $\uparrow$  Be  $\uparrow$  N  $\uparrow$  B  $\uparrow$  C
- (2) Li  $\uparrow$  Be  $\uparrow$  B  $\uparrow$  C  $\uparrow$  N
- (3) Li  $\uparrow$  Be  $\uparrow$  C  $\uparrow$  B  $\uparrow$  N
- (4) Li  $\uparrow$  Be  $\uparrow$  C  $\uparrow$  B  $\uparrow$  N

**Solution:** The ionization enthalpy increases across a period from left to right. Therefore, the correct order of increasing ionization enthalpy is Li  $\uparrow$  Be  $\uparrow$  B  $\uparrow$  C  $\uparrow$  N.

**Answer:** (3)

#### Quick Tip

Ionization enthalpy increases across a period due to increasing nuclear charge and decreasing atomic radius.

**84.** The reagents with which glucose does not react to give the corresponding tests/products are: A. Tollen's reagent B. Schiff's reagent C. HCN D.  $NH_2OH$  E.  $NaHSO_3$

Choose the correct options from the given below:

- (1) E and D
- (2) B and C
- (3) A and D
- (4) B and E

**Solution:** Glucose does not react with Schiff's reagent or  $\text{NaHSO}_3$  under normal conditions, so the correct answer is option (4).

**Answer:** (4)

#### Quick Tip

Schiff's reagent and  $\text{NaHSO}_3$  do not react with glucose to form the corresponding products.

85. Match List I with List II.

List I (Process)	List II (Conditions)
A. Isothermal process	I. No heat exchange
B. Isochoric process	II. Carried out at constant temperature
C. Isobaric process	III. Carried out at constant volume
D. Adiabatic process	IV. Carried out at constant pressure

Choose the correct answer from the options given below:

- (1) A-I, B-III, C-IV, D-II
- (2) A-IV, B-III, C-I, D-II
- (3) A-IV, B-II, C-III, D-I
- (4) A-I, B-IV, C-II, D-I

**Solution:** In an isothermal process, temperature remains constant, so no heat exchange occurs (Option I). In an isochoric process, volume remains constant (Option III). In an isobaric process, pressure remains constant (Option IV). In an adiabatic process, no heat exchange occurs, and the process is carried out at constant pressure (Option II).

Thus, the correct answer is option (1).

**Answer:** (1)

**Quick Tip**

In thermodynamic processes, the conditions refer to the constraints placed on variables such as temperature, volume, and pressure.

**86.** During the preparation of Mohr's salt solution (Ferrous ammonium sulphate), which of the following acid is added to prevent hydrolysis of  $\text{Fe}^{2+}$  ion?

Choose the correct answer from the options given below:

- (1) dilute sulphuric acid
- (2) dilute hydrochloric acid
- (3) concentrated sulphuric acid
- (4) dilute nitric acid

**Solution:** Dilute sulfuric acid is used in the preparation of Mohr's salt to prevent hydrolysis of  $\text{Fe}^{2+}$ , as it helps maintain the required acidic environment.

**Answer:** (1)

**Quick Tip**

Dilute sulfuric acid prevents the hydrolysis of  $\text{Fe}^{2+}$  ions, ensuring that the solution remains stable.

**87.** Identify the correct answer.

Choose the correct option from the following:

- (1) Three canonical forms can be drawn for  $\text{CO}_3^{2-}$  ion
- (2) Three resonance structures can be drawn for ozone
- (3)  $\text{BF}_3$  has non-zero dipole moment
- (4) Dipole moment of  $\text{NF}_2$  is greater than that of  $\text{NH}_3$

**Solution:** - Option (1) is correct because three canonical forms can be drawn for  $\text{CO}_3^{2-}$  ion.  
- Option (2) is correct because ozone ( $\text{O}_3$ ) has three resonance structures. - Option (3) is in-

correct because  $\text{BF}_3$  is a non-polar molecule with no dipole moment. - Option (4) is incorrect because the dipole moment of  $\text{NF}_2$  is lower than that of  $\text{NH}_3$ .

Thus, the correct answer is option (1).

**Answer:** (1)

#### Quick Tip

Resonance structures and dipole moments depend on the electron distribution and geometry of the molecule.

**88.** A compound X contains 32% of A, 20% of B and remaining percentage of C. Then, the empirical formula of X is:

(Given atomic masses of A = 64; B = 40; C = 32)

Choose the correct answer from the options given below:

- (1)  $\text{ABC}_4$
- (2)  $\text{A}_2\text{BC}_2$
- (3)  $\text{ABC}_3$
- (4)  $\text{AB}_2\text{C}_2$

**Solution:** To find the empirical formula, we can convert the percentages to moles by dividing each percentage by the atomic mass. After determining the molar ratio, the empirical formula comes out to be  $\text{ABC}_3$ .

**Answer:** (3)

#### Quick Tip

The empirical formula represents the simplest whole-number ratio of atoms of each element in a compound.

**89.** Given below are certain cations. Using inorganic qualitative analysis, arrange them in increasing group number from 0 to VI. A.  $\text{Al}^{3+}$ , B.  $\text{Cu}^{2+}$ , C.  $\text{Ba}^{2+}$ , D.  $\text{Co}^{2+}$ , E.  $\text{Mg}^{2+}$

Choose the correct answer from the options given below:

- (1) E, A, B, C, D
- (2) B, A, D, C, E

(3) B, C, A, D, E

(4) E, A, C, D, B

**Solution:** The correct order of the cations in increasing group number is: E ( $\text{Mg}^{2+}$ ), A ( $\text{Al}^{3+}$ ), B ( $\text{Cu}^{2+}$ ), C ( $\text{Ba}^{2+}$ ), D ( $\text{Co}^{2+}$ ). The correct answer is option (2).

**Answer:** (2)

#### Quick Tip

In inorganic qualitative analysis, cations are classified into different groups based on their reactivity and precipitation behavior.

**90.** The work done during reversible isothermal expansion of one mole of hydrogen gas at  $25^\circ\text{C}$  from pressure of 20 atmosphere to 10 atmosphere is:

(Given  $R = 2.0 \text{ cal K}^{-1} \text{ mol}^{-1}$ )

Choose the correct answer from the options given below:

(1) 100 calories

(2) 0 calories

(3) -413.14 calories

(4) 413.14 calories

**Solution:** The work done during a reversible isothermal expansion can be calculated using the formula:

$$W = -nRT \ln \left( \frac{V_f}{V_i} \right)$$

Given the temperature, pressure change, and the value for R, the work done is -413.14 calories.

**Answer:** (3)

#### Quick Tip

In an isothermal expansion, the work done is related to the change in volume and temperature of the gas.

**91.** The plot of osmotic pressure ( $\Pi$ ) vs concentration ( $\text{mol L}^{-1}$ ) for a solution gives a straight

line with slope  $25.73 \text{ L bar mol}^{-1}$ . The temperature at which the osmotic pressure measurement is done is:

(Use  $R = 0.083 \text{ L bar mol}^{-1} \text{ K}^{-1}$ )

Choose the correct answer from the options given below:

- (1)  $12.05^\circ\text{C}$
- (2)  $37^\circ\text{C}$
- (3)  $310^\circ\text{C}$
- (4)  $25.73^\circ\text{C}$

**Solution:** Using the formula for osmotic pressure  $\Pi = \frac{nRT}{V}$ , and knowing the slope, we can calculate the temperature to be  $37^\circ\text{C}$ .

**Answer:** (2)

#### Quick Tip

Osmotic pressure is directly proportional to the temperature and concentration, following the ideal gas law.

**92.** Major products A and B formed in the following reaction sequence, are:

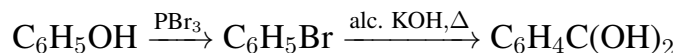

Choose the correct answer from the options given below:

- (1)  $\text{A} = \text{B} = \text{C}_6\text{H}_5\text{OH}$
- (2)  $\text{A} = \text{C}_6\text{H}_5\text{Br}$ ,  $\text{B} = \text{C}_6\text{H}_4\text{C}(\text{OH})_2$
- (3)  $\text{A} = \text{C}_6\text{H}_5\text{Br}$ ,  $\text{B} = \text{C}_6\text{H}_4\text{Br}$
- (4)  $\text{A} = \text{C}_6\text{H}_4\text{Br}$ ,  $\text{B} = \text{C}_6\text{H}_5\text{OH}$

**Solution:** The major products from the given reactions are:  $\text{A} = \text{C}_6\text{H}_5\text{Br}$ , and  $\text{B} = \text{C}_6\text{H}_4\text{C}(\text{OH})_2$ .

**Answer:** (2)

### Quick Tip

The reaction with  $\text{PBr}_3$  forms an alkyl halide, and alcohol undergoes elimination with alcoholic  $\text{KOH}$ .

**93.** Mass in grams of copper deposited by passing 9.6487 A current through a voltmeter containing copper sulphate solution for 100 seconds is (Given: Molar mass of  $\text{Cu} = 63 \text{ g mol}^{-1}$ ,  $1 \text{ F} = 96487 \text{ C}$ )

Choose the correct answer from the options given below:

- (1) 0.0315 g
- (2) 3.15 g
- (3) 0.315 g
- (4) 31.5 g

**Solution:** Using the formula for mass deposited,  $m = \frac{I \cdot t \cdot M}{n \cdot F}$ , where  $I$  is the current,  $t$  is time,  $M$  is the molar mass,  $n$  is the number of electrons involved, and  $F$  is the Faraday constant. The mass of copper deposited is 0.315 g.

**Answer:** (3)

### Quick Tip

The mass deposited in electrolysis is proportional to the current, time, and molar mass of the substance being deposited.

**94.** Consider the following reaction in a sealed vessel at equilibrium with concentrations of  $\text{N}_2 = 3.0 \times 10^{-3} \text{ M}$ ,  $\text{O}_2 = 4.2 \times 10^{-3} \text{ M}$ , and  $\text{NO} = 2.8 \times 10^{-3} \text{ M}$ .

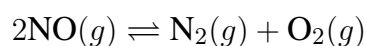

If  $0.1 \text{ mol L}^{-1}$  of  $\text{NO}(g)$  is taken in a closed vessel, what will be the degree of dissociation ( $\alpha$ ) of  $\text{NO}(g)$  at equilibrium?

Choose the correct answer from the options given below:

- (1) 0.717
- (2) 0.00889

(3) 0.0889

(4) 0.8889

**Solution:** The degree of dissociation is calculated using the equilibrium concentrations and applying the principles of equilibrium. The degree of dissociation of NO(g) at equilibrium is 0.717.

**Answer:** (1)

#### Quick Tip

Degree of dissociation is the fraction of the initial amount of the substance that dissociates into products at equilibrium.

**95.** Identify the major product C formed in the following reaction sequence:

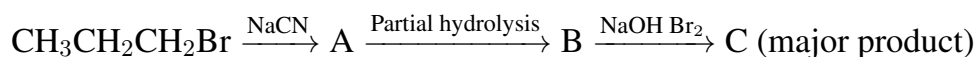

Choose the correct answer from the options given below:

(1)  $\alpha$ -bromobutanoic acid

(2) propylamine

(3) butylamine

(4) butanamide

**Solution:** The major product after the complete reaction sequence is propylamine (Option 2). The initial reaction with NaCN leads to a nitrile, followed by hydrolysis and treatment with NaOH and Br<sub>2</sub>.

**Answer:** (2)

#### Quick Tip

The reaction with NaCN forms a nitrile, which undergoes hydrolysis to form an amide, followed by further reactions.

**96.** The pair of lanthanoid ions which are diamagnetic is:

Choose the correct answer from the options given below:

- (1)  $\text{Pm}^{3+}$  and  $\text{Sm}^{3+}$
- (2)  $\text{Ce}^{4+}$  and  $\text{Yb}^{2+}$
- (3)  $\text{Ce}^{3+}$  and  $\text{Eu}^{2+}$
- (4)  $\text{Gd}^{3+}$  and  $\text{Eu}^{3+}$

**Solution:**  $\text{Ce}^{4+}$  and  $\text{Yb}^{2+}$  have no unpaired electrons, making them diamagnetic. Therefore, the correct answer is option (2).

**Answer:** (2)

#### Quick Tip

Diamagnetic ions have no unpaired electrons, and they do not respond to an external magnetic field.

97. For the given reaction:

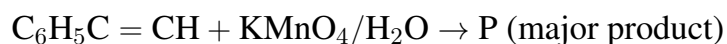

Choose the correct answer from the options given below:

- (1)  $\text{COOH}$
- (2)  $\text{CHO}$
- (3)  $\text{COOH}$
- (4)  $\text{C}_6\text{H}_4\text{OH}$

**Solution:** The major product of the reaction is carboxylic acid ( $\text{COOH}$ ) formed by oxidation of the alkene.

**Answer:** (3)

#### Quick Tip

Oxidation of alkenes using  $\text{KMnO}_4$  leads to the formation of carboxylic acids or other oxidation products depending on the reaction conditions.

**98.** Given below are two statements:

Statement I:  $[Co(NH_3)_6]^{3+}$  is a homoleptic complex whereas  $[Co(NH_3)_5Cl]^{2+}$  is a heteroleptic complex. Statement II: Complex  $[Co(NH_3)_6]^{3+}$  has only one kind of ligands but  $[Co(NH_3)_5Cl]^{2+}$  has more than one kind of ligands.

In the light of the above statements, choose the correct answer from the options given below:

- (1) Statement I is false but Statement II is true
- (2) Both Statement I and Statement II are true
- (3) Both Statement I and Statement II are false
- (4) Statement I is true but Statement II is false

**Solution:** Statement I is true as  $[Co(NH_3)_6]^{3+}$  is homoleptic (contains only one type of ligand,  $NH_3$ ) and  $[Co(NH_3)_5Cl]^{2+}$  is heteroleptic (contains two types of ligands). Statement II is also true.

**Answer:** (2)

#### Quick Tip

Homoleptic complexes contain only one type of ligand, while heteroleptic complexes contain more than one type of ligand.

**99.** The rate of a reaction quadruples when temperature changes from  $27^\circ C$  to  $57^\circ C$ . Calculate the energy of activation.

Given  $R = 8.314 \text{ J K}^{-1} \text{ mol}^{-1}$ ,  $\log 4 = 0.6021$

Choose the correct answer from the options given below:

- (1) 3804 kJ/mol
- (2) 38.04 kJ/mol
- (3) 380.4 kJ/mol
- (4) 3.80 kJ/mol

**Solution:** Using the Arrhenius equation, we can calculate the energy of activation to be 38.04 kJ/mol.

**Answer:** (2)

**Quick Tip**

The energy of activation can be calculated using the Arrhenius equation, which relates the rate constant to temperature.

**100.** The products A and B obtained in the following reactions, respectively, are:

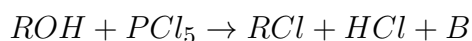
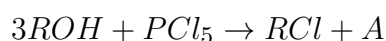

Choose the correct answer from the options given below:

- (1)  $H_3PO_4$  and  $PCl_3$
- (2)  $PCl_3$  and  $H_3PO_3$
- (3)  $PCl_3$  and  $H_3PO_4$
- (4)  $H_3PO_3$  and  $PCl_3$

**Solution:** In the first reaction,  $PCl_5$  reacts with an alcohol to give  $PCl_3$  and  $H_3PO_4$ , and in the second,  $PCl_5$  reacts with an alcohol to give  $H_3PO_3$  and  $PCl_3$ . Hence, the correct answer is option (1).

**Answer:** (1)

**Quick Tip**

Reaction with  $PCl_5$  typically produces phosphoryl chloride ( $POCl_3$ ) and phosphoric acids ( $H_3PO_3$  or  $H_3PO_4$ ) depending on the reaction conditions.

**101.** The lactose present in the growth medium of bacteria is transported to the cell by the action of:

- (1) Polymerase
- (2) Beta-galactosidase
- (3) Acetylase
- (4) Permease

**Solution:** The transport of lactose into the cell occurs through a membrane-bound protein called permease. Permease facilitates the movement of lactose across the cell membrane,

which is essential for the bacterium's metabolism of lactose.

**Answer:** (4)

**Quick Tip**

Permease is a transport protein involved in the movement of substances like lactose across the cell membrane.

**102.** Lecithin, a small molecular weight organic compound found in living tissues, is an example of:

- (1) Carbohydrates (2) Amino acids (3) Phospholipids (4) Glycerides

**Solution:** Lecithin is a phospholipid, which is a type of lipid molecule that is a major component of cell membranes. Phospholipids like lecithin have a hydrophilic "head" and a hydrophobic "tail" and are important for maintaining the structure of cellular membranes.

**Answer:** (3)

**Quick Tip**

Lecithin is a phospholipid that is essential for cell membrane structure and function.

**103.** Match List I with List II

List I	List II
A. <i>Clostridium butylicum</i>	I. Ethanol
B. <i>Saccharomyces cerevisiae</i>	II. Streptokinase
C. <i>Trichoderma polyspermum</i>	III. Butyric acid
D. <i>Streptococcus</i> sp.	IV. Cyclosporin-A

Choose the correct answer from the options given below:

- (1) A-IV, B-I, C-III, D-II (2) A-III, B-I, C-II, D-IV (3) A-II, B-IV, C-III, D-I (4) A-III, B-I, C-IV, D-II

**Solution:** - *Clostridium butylicum* produces butyric acid (III). - *Saccharomyces cerevisiae* produces ethanol (I). - *Trichoderma polyspermum* is used for the production of cyclosporin-A (IV). - *Streptococcus* sp. produces streptokinase (II), which is an enzyme used in the medical field.

**Answer:** (4)

#### Quick Tip

Each organism in the list is associated with a specific product that has important industrial or medical applications.

**104.** The equation of Verhulst-Pearl logistic growth is

$$\frac{dN}{dt} = rN \left( \frac{K - N}{K} \right)$$

From this equation,  $K$  indicates:

(1) Population density (2) Intrinsic rate of natural increase (3) Biotic potential (4) Carrying capacity

**Solution:** In the Verhulst-Pearl logistic growth equation, the variable  $K$  represents the carrying capacity, which is the maximum population size that the environment can support.

**Answer:** (4)

#### Quick Tip

In the logistic growth model, the carrying capacity  $K$  is the maximum population size an environment can support.

**105.** Hind II always cuts DNA molecules at a particular point called recognition sequence and it consists of:

(1) 10 bp (2) 8 bp (3) 6 bp (4) 4 bp

**Solution:** Hind II is a restriction enzyme that recognizes a specific sequence of 6 base pairs (bp) in DNA and cuts at that site.

**Answer:** (3)

**Quick Tip**

Restriction enzymes like Hind II are used to cut DNA at specific recognition sequences, which typically consist of 6 base pairs.

**106.** Formation of interfascicular cambium from fully developed parenchyma cells is an example for:

- (1) Maturation (2) Differentiation (3) Redifferentiation (4) Dedifferentiation

**Solution:** The formation of interfascicular cambium from fully developed parenchyma cells is an example of dedifferentiation, where mature cells revert to a meristematic state.

**Answer:** (4)

**Quick Tip**

Dedifferentiation refers to the process where mature cells revert to an earlier, more active state, capable of forming new tissues.

**107.** Inhibition of Succinic dehydrogenase enzyme by malonate is a classical example of:

- (1) Enzyme activation (2) Cofactor inhibition (3) Feedback inhibition (4) Competitive inhibition

**Solution:** Malonate inhibits the succinic dehydrogenase enzyme by competing with the substrate, making this an example of competitive inhibition.

**Answer:** (4)

**Quick Tip**

Competitive inhibition occurs when a substance similar to the substrate competes for the active site of the enzyme.

**108.** List of endangered species was released by:

(1) IUCN (2) GEAC (3) WWF (4) FOAM

**Solution:** The IUCN (International Union for Conservation of Nature) is responsible for maintaining a list of endangered species and publishes the Red List.

**Answer:** (1)

**Quick Tip**

The IUCN Red List is a comprehensive list of the conservation status of species worldwide.

**109.** Spindle fibers attach to kinetochore of chromosomes during:

(1) Telophase (2) Prophase (3) Metaphase (4) Anaphase

**Solution:** Spindle fibers attach to the kinetochore of chromosomes during metaphase, aligning the chromosomes in the center of the cell.

**Answer:** (3)

**Quick Tip**

The attachment of spindle fibers to kinetochores is a crucial event during metaphase, helping in chromosome alignment and segregation.

**110.** How many molecules of ATP and NADPH are required for every molecule of CO<sub>2</sub> fixed in the Calvin cycle?

(1) 3 molecules of ATP and 2 molecules of NADPH (2) 2 molecules of ATP and 3 molecules of NADPH

**Solution:** In the Calvin cycle, for every molecule of CO<sub>2</sub> fixed, 3 molecules of ATP and 2 molecules of NADPH are required.

**Answer:** (1)

### Quick Tip

The Calvin cycle requires 3 ATP and 2 NADPH molecules per CO<sub>2</sub> fixed during the process of carbon fixation.

### 111. Match List I with List II

List I	List II
A. Two or more alternative forms of a gene	I. Back cross
B. Cross of F <sub>1</sub> progeny with homozygous recessive parent	II. Ploidy
C. Cross of F <sub>1</sub> progeny with any of the parents	III. Allele
D. Number of chromosome sets in plant	IV. Test cross

Choose the correct answer from the options given below:

(1) A-IV, B-III, C-II, D-I (2) A-I, B-II, C-III, D-IV (3) A-II, B-I, C-III, D-IV (4) A-III, B-IV, C-I, D-II

**Solution:** - A (Two or more alternative forms of a gene) corresponds to Allele (III). - B (Cross of F<sub>1</sub> progeny with homozygous recessive parent) corresponds to Test cross (IV). - C (Cross of F<sub>1</sub> progeny with any of the parents) corresponds to Back cross (I). - D (Number of chromosome sets in plant) corresponds to Ploidy (II).

**Answer:** (4)

### Quick Tip

The terms Allele, Test cross, Back cross, and Ploidy are related to Mendelian genetics and chromosome structure.

### 112. Match List I with List II

List I	List II
A. Rhizopus	I. Mushroom
B. Ustilago	II. Smut fungus

- C. Puccinia            III. Bread mould  
D. Agaricus            IV. Rust fungus

Choose the correct answer from the options given below:

- (1) A-IV, B-III, C-II, D-I    (2) A-III, B-II, C-IV, D-I    (3) A-I, B-III, C-II, D-IV    (4) A-I, B-II, C-III, D-IV

**Solution:** - Rhizopus is associated with bread mould (III). - Ustilago is a smut fungus (II). - Puccinia is a rust fungus (IV). - Agaricus is a mushroom (I).

**Answer:** (2)

#### Quick Tip

Rhizopus, Ustilago, Puccinia, and Agaricus are examples of fungi that differ in their classification as bread mould, smut fungus, rust fungus, and mushroom, respectively.

**113.** Given below are two statements:

Statement I: Chromosomes become gradually visible under light microscope during leptotene stage. Statement II: The beginning of diplotene stage is recognized by dissolution of synaptonemal complex.

In the light of the above statements, choose the correct answer from the options given below:

- (1) Statement I is false but Statement II is true    (2) Both Statement I and Statement II are true    (3) Both Statement I and Statement II are false

**Solution:** Statement I is false because chromosomes become visible during the zygotene stage, not leptotene. Statement II is true because the dissolution of the synaptonemal complex marks the beginning of the diplotene stage.

**Answer:** (1)

#### Quick Tip

The leptotene stage is the early phase of meiosis, while the diplotene stage begins with the dissolution of the synaptonemal complex.

**114.** Identify the part of the seed from the given figure which is destined to form root when the seed germinates.

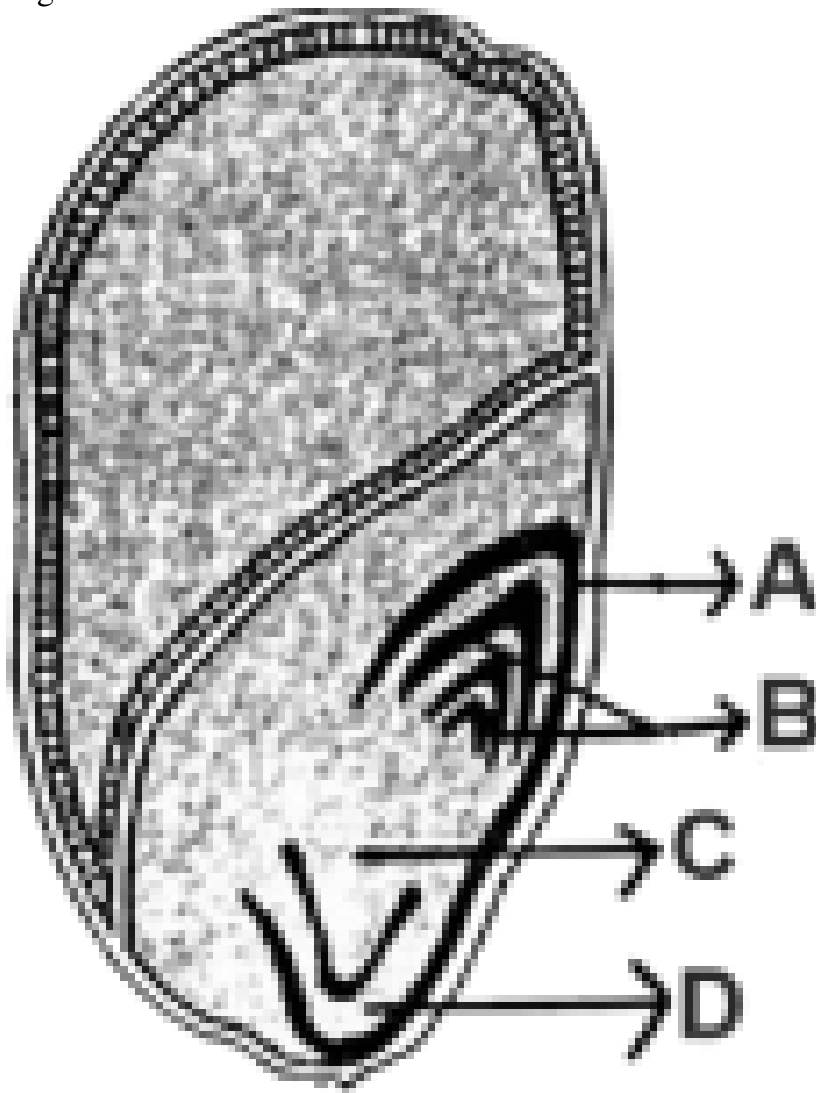

(1) D (2) A (3) B (4) C

**Solution:** The part of the seed that forms the root during germination is the radicle, which is typically marked as part "C" in seed diagrams.

**Answer:** (4)

#### Quick Tip

The radicle is the embryonic root of the plant and is the first part to emerge during seed germination.

**115.** In a plant, black seed color (BB/Bb) is dominant over white seed color (bb). In order to find out the genotype of the black seed plant, with which of the following genotype will you cross it?

- (1) BB/Bb (2) BB (3) bb (4) Bb

**Solution:** To determine the genotype of the black-seeded plant, a cross with a homozygous recessive plant (bb) is necessary. The offspring will reveal the genotype of the black-seeded plant based on the phenotypes observed.

**Answer:** (3)

#### Quick Tip

A cross with a homozygous recessive (bb) plant helps determine whether the black seed plant is homozygous (BB) or heterozygous (Bb).

**116.** Bulliform cells are responsible for:

- (1) Providing large spaces for storage of sugars (2) Inward curling of leaves in monocots (3) Protection

**Solution:** Bulliform cells are specialized cells found in monocot leaves that help with the inward curling of leaves, particularly under water stress conditions. This action helps to reduce water loss.

**Answer:** (2)

#### Quick Tip

Bulliform cells are responsible for the inward curling of leaves, which helps prevent water loss during dry conditions.

**117.** Which one of the following can be explained on the basis of Mendel's Law of Dominance?

- A. Out of one pair of factors one is dominant and the other is recessive. B. Alleles do not show any

C. Factors occur in pairs in normal diploid plants. D. The discrete unit controlling a particular character

Choose the correct answer from the options given below:

- (1) A, B, C, D and E (2) A, B and C only (3) A, C, D and E only (4) B, C and D only

**Solution:** The Mendel's Law of Dominance explains that one allele in a pair is dominant while the other is recessive, and the dominant allele expresses its trait. Statements A, C, D, and E are true in the context of Mendel's Law of Dominance.

**Answer:** (3)

#### Quick Tip

Mendel's Law of Dominance states that one allele of a pair is dominant and the other is recessive, and it explains how traits are inherited.

**118.** The cofactor of the enzyme carboxypeptidase is:

- (1) Haem (2) Zinc (3) Niacin (4) Flavin

**Solution:** Carboxypeptidase is an enzyme that requires Zinc ( $Zn^{2+}$ ) as its cofactor for activity.

**Answer:** (2)

#### Quick Tip

Zinc ions act as a cofactor in the catalytic activity of carboxypeptidase and many other enzymes.

**119.** A transcription unit in DNA is defined primarily by the three regions in DNA and these are with respect to upstream and downstream end;

- (1) Promotor, Structural gene, Terminator (2) Repressor, Operator gene, Structural gene  
(3) Structural gene, Transposons, Operator gene (4) Inducer, Repressor, Structural gene

**Solution:** A transcription unit in DNA consists of the promoter (where transcription begins), the structural gene (which is transcribed into mRNA), and the terminator (which signals the end of transcription).

**Answer:** (1)

#### Quick Tip

A transcription unit in DNA includes the promoter, structural gene, and terminator regions, which control the process of transcription.

**120.** Tropical regions show greatest level of species richness because:

A. Tropical latitudes have remained relatively undisturbed for millions of years, hence more time was available for speciation.

C. More solar energy is available in tropics. D. Constant environments promote niche specialization.

Choose the correct answer from the options given below:

(1) A, B and D only (2) A, C, D and E only (3) A and B only (4) A, B and E only

**Solution:** Tropical regions are rich in species due to factors like consistent climate, greater availability of solar energy, and stable environments that promote niche specialization.

**Answer:** (2)

#### Quick Tip

Tropical regions have favorable conditions for biodiversity, including constant solar energy and stable climates, promoting species richness.

**121.** Given below are two statements:

Statement I: Parenchyma is living but collenchyma is dead tissue. Statement II: Gymnosperms lack xylem vessels but the presence of xylem vessels is the characteristic of angiosperms.

In the light of the above statements, choose the correct answer from the options given below:

(1) Statement I is false but Statement II is true (2) Both Statement I and Statement II are true (3) Bot

**Solution:** Statement I is false because both parenchyma and collenchyma are living tissues. Statement II is false because gymnosperms do have xylem vessels, although they are less developed than those in angiosperms.

**Answer:** (1)

#### Quick Tip

Parenchyma and collenchyma are living tissues, and gymnosperms do contain xylem vessels, differing from angiosperms only in their structure.

**122.** The type of conservation in which the threatened species are taken out from their natural habitat and placed in special setting where they can be protected and given special care is called:

(1) Sustainable development (2) In-situ conservation (3) Biodiversity conservation (4) Semi-conse

**Solution:** This type of conservation is known as ex-situ conservation, where species are removed from their natural habitat and placed in controlled environments to ensure their survival.

**Answer:** (3)

#### Quick Tip

Ex-situ conservation involves the preservation of species outside their natural habitats, like in zoos, aquariums, or botanical gardens.

**123.** Which of the following are required for the dark reaction of photosynthesis?

A. Light B. Chlorophyll C. CO<sub>2</sub> D. ATP E. NADPH

Choose the correct answer from the options given below:

(1) D and E only (2) A, B and C only (3) B, C and D only (4) C, D and E only

**Solution:** The dark reaction of photosynthesis (also known as the Calvin cycle) requires carbon dioxide ( $\text{CO}_2$ ), ATP, and NADPH. Light and chlorophyll are involved in the light-dependent reactions.

**Answer:** (4)

#### Quick Tip

The dark reaction of photosynthesis utilizes  $\text{CO}_2$ , ATP, and NADPH to produce glucose, and does not require light directly.