

NEET UG 2024 Q6 Question Paper with Solutions

Time Allowed :200 minutes	Maximum Marks :720	Total questions :200
----------------------------------	---------------------------	-----------------------------

General Instructions

Read the following instructions very carefully and strictly follow them:

1. The test is of 3 hours 20 minutes duration.
2. The question paper consists of 200 questions out of which 180 MCQs must be answered. The maximum marks are 720.
3. There are four parts in the question paper consisting of Biology, Physics, Chemistry and Mathematics.
4. Each subject will be divided into two sections, A and B which will have 35 and 15 questions respectively. Candidates will have to answer only 10 questions in Section B.
5. 4 marks are awarded for each correct answer and 1 mark is deducted for each wrong answer

Physics

Section A

1. A bob is whirled in a horizontal plane by means of a string with an initial speed of ω rpm. The tension in the string is T . If the speed increases to 2ω while keeping the radius constant, what happens to the tension in the string?

(1) T

(2) $4T$

(3) $\frac{T}{4}$

(4) $\sqrt{2}T$

Correct Answer: (2) $4T$

Solution:

The tension in the string is related to the square of the velocity, meaning:

$$T \propto v^2$$

This indicates that the tension is directly proportional to the square of the velocity.

Therefore, we introduce a constant k to express this mathematically:

$$T = kv^2$$

When the velocity doubles from v to $2v$, we substitute $2v$ into the equation:

$$T' = k(2v)^2 = k \cdot 4v^2$$

This leads to:

$$T' = 4T$$

Thus, when the velocity doubles, the tension becomes four times greater than the initial tension. Therefore, $T \rightarrow 4T$.

Quick Tip

The tension in the string increases with the square of the velocity in circular motion.

2. A particle moving with uniform speed in a circular path maintains:

- (1) Constant velocity
- (2) Constant acceleration
- (3) Constant velocity but varying acceleration
- (4) Varying velocity and varying acceleration

Correct Answer: (4) Varying velocity and varying acceleration

Solution: Step 1: Concept of motion in a circle.

Although the particle maintains a uniform speed, its direction is constantly changing as it moves along the circular path. This means the velocity vector keeps changing direction.

Step 2: Analyzing velocity and acceleration.

Velocity, being a vector, changes continuously due to the change in direction, so the velocity is not constant. Similarly, the direction of acceleration, which always points toward the center, keeps changing.

Conclusion: Thus, the velocity and acceleration both vary with time.

Quick Tip

In uniform circular motion, while the speed remains constant, both velocity and acceleration are continuously changing.

3. A logic circuit provides the output Y as per the following truth table. The expression for the output Y is:

A	B	Y
0	0	0
0	1	1
1	0	1
1	1	0

- (A) $A\bar{B} + \bar{A}$
- (B) $A\bar{B} + \bar{A}$
- (C) \bar{B}

(D) B

Correct Answer: (3) \overline{B}

Solution: By examining the truth table:

- When $A = 0, B = 0, Y = 1$.
- When $A = 0, B = 1, Y = 0$.
- When $A = 1, B = 0, Y = 1$.
- When $A = 1, B = 1, Y = 0$.

From the truth table, we observe that Y is 1 when $B = 0$, regardless of the value of A .

Therefore, $Y = \overline{B}$.

Thus, the Boolean expression for Y is \overline{B} .

Quick Tip

To derive the Boolean expression from a truth table, focus on the conditions when the output is 1 and write the corresponding product terms.

4. In the given diagram, a strong bar magnet is moved through a loop. The direction of the induced current is:

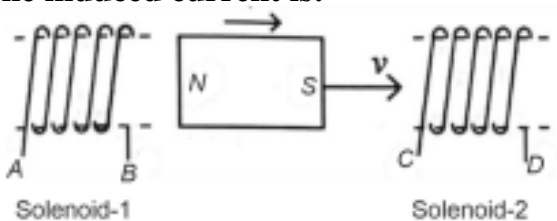

- (1) AB and DC
- (2) BA and CD
- (3) AB and CD
- (4) BA and DC

Correct Answer: (1) AB and DC

Solution: Step 1: Apply Lenz's Law. According to Lenz's Law, the induced current always opposes the change in magnetic flux that causes it.

Step 2: Determine the direction of current. As the magnet moves through the loop, the induced current will flow in such a way that it opposes the motion of the magnet. Based on the direction of the magnet's movement, the current flows in the AB and DC directions.

Conclusion: Hence, the induced current flows in the directions AB and DC.

Quick Tip

Lenz's Law ensures that the induced current opposes the change in magnetic flux, helping us predict the direction of the induced current.

5. Given below are two statements: one is labelled as Assertion A and the other is labelled as Reason R.

Assertion A: The potential V at any axial point, at a 2 m distance r from the center of the dipole with dipole moment vector \vec{P} of magnitude 4×10^{-6} C m, is $\pm 9 \times 10^3$ V.

Reason R: $V = \pm \frac{2P}{4\pi\epsilon_0 r^2}$, where r is the distance of any axial point situated 2 m from the center of the dipole.

In light of the above statements, choose the correct answer from the options below:

- (1) Both A and R are true and R is the correct explanation of A.
- (2) Both A and R are true and R is not the correct explanation of A.
- (3) A is true but R is false.
- (4) A is false but R is true.

Correct Answer: (3) A is true but R is false.

Solution: Step 1: Analyze Assertion (A). The potential at an axial point for a dipole is given by the formula:

$$V = \pm \frac{2P}{4\pi\epsilon_0 r^2}$$

For $r = 2$ m, the potential is $\pm 9 \times 10^3$ V, which matches the given assertion.

Step 2: Evaluate Reason (R). Reason (R) gives a similar formula but incorrectly includes the factor of 2 in front of the dipole moment. The correct formula is:

$$V = \pm \frac{P}{4\pi\epsilon_0 r^2}$$

Thus, Reason (R) is false.

Conclusion: Since Assertion (A) is true, but Reason (R) is false, the correct answer is option (3).

Quick Tip

The potential of a dipole along the axial line is given by $V = \pm \frac{P}{4\pi\epsilon_0 r^2}$, not $\frac{2P}{4\pi\epsilon_0 r^2}$.

6. Match List-I with List-II:

List-I (Material)	List-II (Susceptibility χ)
A. Diamagnetic	$\chi = 0$
B. Ferromagnetic	$\chi \ll 1$
C. Paramagnetic	$0 < \chi \ll 1$
D. Non-magnetic	$0 < \chi < \epsilon$

- (1) A-II, B-III, C-IV, D-I
- (2) A-II, B-I, C-III, D-IV
- (3) A-III, B-II, C-I, D-IV
- (4) A-IV, B-III, C-II, D-I

Correct Answer: (1) A-II, B-III, C-IV, D-I

Solution: Step 1: Identify material properties. - Diamagnetic materials are weakly repelled by a magnetic field (*I*). - Paramagnetic materials are weakly attracted by a magnetic field (*II*). - Ferromagnetic materials are strongly attracted by a magnetic field (*III*). - Non-magnetic materials show no interaction with magnetic fields (*IV*).

Step 2: Match the materials and their susceptibility values. From the properties of these materials, the correct matching is:

A-II, B-III, C-IV, D-I

Conclusion: The correct matching is option (1).

Quick Tip

Different materials exhibit distinct magnetic susceptibilities. Remember the behavior of diamagnetic, paramagnetic, and ferromagnetic materials for better understanding.

7. In a uniform magnetic field of 0.049 T, a magnetic needle performs 20 complete oscillations in 5 seconds as shown. The moment of inertia of the needle is 9.8×10^{-6} kg

m^2 . If the magnitude of the magnetic moment of the needle is $x \times 10^{-5} \text{ Am}^2$, then the

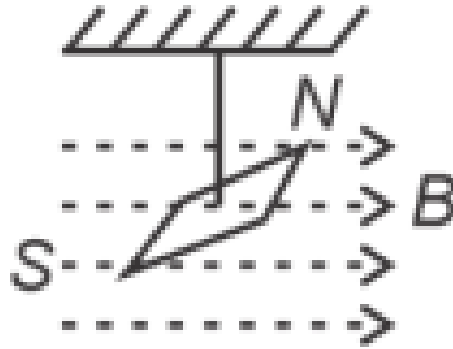

value of 'x' is:

- (1) $5\pi^2$
- (2) $128\pi^2$
- (3) $50\pi^2$
- (4) $1280\pi^2$

Correct Answer: (4) $1280\pi^2$

Solution:

Given values:

$$B = 0.049 \text{ T}, \quad f = \frac{20}{5} = 4 \text{ Hz}$$

$$I = 9.8 \times 10^{-6} \text{ kg m}^2$$

$$M = x \times 10^{-5} \text{ A m}^2$$

The formula for frequency f is given by:

$$f = \frac{1}{2\pi} \sqrt{\frac{MB}{I}}$$

Substituting the known values:

$$M = \frac{f^2 I (4\pi^2)}{B} = \frac{16 \times 4\pi^2 \times 98 \times 10^{-7}}{49 \times 10^{-3}}$$

Simplifying:

$$x \times 10^{-5} = 128\pi^2 \times 10^{-4}$$

Therefore:

$$x = 1280\pi^2$$

Quick Tip

The frequency of oscillation of a magnetic needle is influenced by both the magnetic moment and the moment of inertia of the needle.

8. In an ideal transformer, the turns ratio is $\frac{N_p}{N_s} = \frac{1}{2}$. The ratio $V_s : V_p$ is equal to (the symbols carry their usual meaning):

- (1) 1 : 2
- (2) 2 : 1
- (3) 1 : 1
- (4) 1 : 4

Correct Answer: (2) 2 : 1

Solution: Recall the transformer equation. For an ideal transformer, the relationship between the primary voltage (V_p) and the secondary voltage (V_s) is given by:

$$\frac{V_p}{V_s} = \frac{N_p}{N_s}$$

where: N_p and N_s are the number of turns in the primary and secondary coils.

The voltage ratio is related to the turns ratio by:

$$\frac{V_s}{V_p} = \frac{N_s}{N_p} = 2 : 1$$

Thus, for this ideal transformer, the ratio of the secondary voltage to the primary voltage is equal to the ratio of the number of turns in the secondary coil to the number of turns in the primary coil.

Conclusion: The correct ratio is 2 : 1.

Quick Tip

In an ideal transformer, the voltage ratio is directly proportional to the turns ratio of the coils.

9. In a vernier calipers, $(N + 1)$ divisions of the vernier scale coincide with N divisions of the main scale. If 1 MSD represents 0.1 mm, the vernier constant (in cm) is:

- (1) $\frac{1}{10N}$
- (2) $\frac{1}{100(N+1)}$
- (3) $100N$
- (4) $10(N + 1)$

Correct Answer: (2) $\frac{1}{100(N+1)}$

Solution: The vernier constant (VC) is defined as the difference between one main scale division (MSD) and one vernier scale division (VSD). Given that $(N + 1)$ divisions of the vernier scale coincide with N divisions of the main scale, the VC can be expressed as:

Step 1: Using the formula for VC. The vernier constant is:

$$VC = 1 \text{ MSD} - 1 \text{ VSD}$$

Since $(N + 1) \text{ VSD} = N \text{ MSD}$, we find:

$$1 \text{ VSD} = \frac{N}{N + 1} \text{ MSD}$$

Step 2: Calculating the VC.

$$VC = 0.1 - \frac{N}{N + 1} \times 0.1 = \frac{0.1}{N + 1}$$

Converting to cm:

$$VC = \frac{1}{100(N + 1)}$$

Conclusion: Thus, the correct answer is (2).

Quick Tip

The vernier constant is a critical factor for calculating the least count of a vernier caliper and measuring fractions of a unit.

10. A horizontal force of 10 N is applied to a block A as shown in the figure. The mass of blocks A and B are 2 kg and 3 kg respectively. The blocks slide over a frictionless surface. The force exerted by block A on block B is:

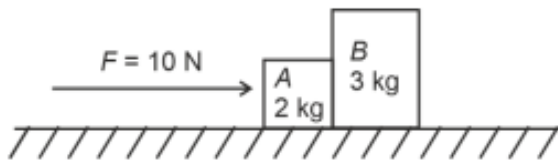

- (1) Zero
- (2) 4 N
- (3) 6 N
- (4) 10 N

Correct Answer: (3) 6 N

Solution:

Using Newton's Second Law:

$$F_{\text{net}} = ma$$

For the system of two blocks, with the given information:

$$\text{Block A: } F - N = 2a \quad \text{or} \quad 10 - N = 2a \quad \dots \text{(i)}$$

$$\text{Block B: } N = 3a \quad \dots \text{(ii)}$$

Substitute equation (ii) into equation (i):

$$10 - 3a = 2a$$

Simplifying:

$$10 = 5a$$

Solving for a :

$$a = 2 \text{ m/s}^2$$

Substitute $a = 2 \text{ m/s}^2$ into equation (ii) to find N :

$$N = 3a = 6 \text{ N}$$

Thus, the force exerted by block A on block B is 6 N.

Quick Tip

To find the force between two blocks in contact, use Newton's Second Law for each block and solve the system of equations.

11. If $x = 5 \sin\left(\pi t + \frac{\pi}{3}\right)$ m represents the motion of a particle executing simple harmonic motion, the amplitude and time period of motion, respectively, are:

- (1) 5 cm, 2 s
- (2) 5 m, 2 s
- (3) 5 m, 1 s
- (4) 5 cm, 1 s

Correct Answer: (2) 5 m, 2 s

Solution:

The equation of motion is given by:

$$x = 5 \sin\left(\pi t + \frac{\pi}{3}\right)$$

Comparing this equation with the standard equation for simple harmonic motion:

$$x = A \sin(\omega t + \phi)$$

we can identify the amplitude $A = 5$ m.

The angular frequency $\omega = \pi$, and the time period T is related to the angular frequency by:

$$T = \frac{2\pi}{\omega} = \frac{2\pi}{\pi} = 2 \text{ s}$$

Thus, the amplitude is 5 m, and the time period is 2 s.

Quick Tip

The time period of simple harmonic motion depends on the angular frequency ω , and is given by $T = \frac{2\pi}{\omega}$.

12. The terminal voltage of the battery, whose emf is 10 V and internal resistance 1 Ω , when connected through an external resistance of 4 Ω as shown in the figure is:

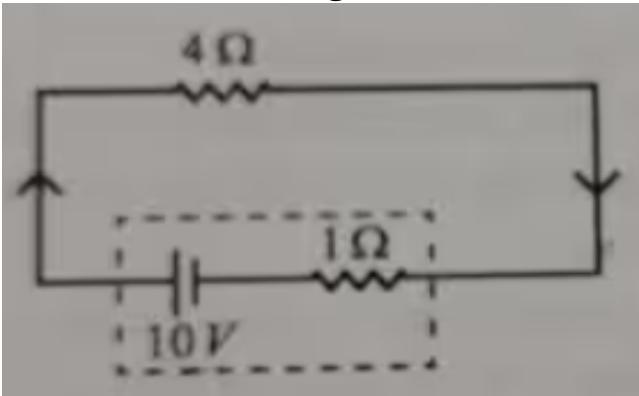

- (1) 4 V
- (2) 6 V
- (3) 8 V
- (4) 10 V

Correct Answer: (3) 8 V

Solution:

The circuit consists of a 10 V battery, a 4 Ω resistor, and a 1 Ω resistor in series.

First, we calculate the total current I using the formula for series circuits:

$$I = \frac{E}{R + r}$$

where: - $E = 10$ V is the electromotive force (EMF), - $R = 4$ Ω is the resistance of the 4 Ω resistor, and - $r = 1$ Ω is the resistance of the 1 Ω resistor.

Substituting the values:

$$I = \frac{10}{4 + 1} = \frac{10}{5} = 2 \text{ A}$$

Thus, the current I in the circuit is 2 A.

Next, we calculate the potential drop across the 1 Ω resistor, denoted as V_T . The potential drop is given by:

$$V_T = E - I \cdot r$$

Substituting the known values:

$$V_T = 10 - 2 \cdot 1 = 10 - 2 = 8 \text{ V}$$

Thus, the potential drop across the 1Ω resistor is 8 V .

Quick Tip

The terminal voltage of a battery decreases when the current flows through its internal resistance.

13. Given below are two statements:

Statement I: Atoms are electrically neutral as they contain equal number of positive and negative charges.

Statement II: Atoms of each element are stable and emit their characteristic spectrum.

In the light of the above statements, choose the most appropriate answer from the options given below:

- (1) Both Statement I and Statement II are correct
- (2) Both Statement I and Statement II are incorrect
- (3) Statement I is correct but Statement II is incorrect
- (4) Statement I is incorrect but Statement II is correct

Correct Answer: (3) Statement I is correct but Statement II is incorrect

Solution: Statement I is correct because atoms are electrically neutral due to the equal number of positive protons and negative electrons. Statement II is incorrect because while atoms are stable, they do not necessarily emit a characteristic spectrum unless they are excited or subjected to certain conditions. Only then can they emit photons with specific energies corresponding to their energy levels.

Quick Tip

The characteristic spectrum of an atom is observed when electrons transition between energy levels, typically when the atom is excited.

14. If c is the velocity of light in free space, the correct statements about photon among

the following are:

- A. The energy of a photon is $E = h\nu$.
- B. The velocity of a photon is c .
- C. The momentum of a photon, $p = \frac{h\nu}{c}$.
- D. In a photon-electron collision, both total energy and total momentum are conserved.
- E. Photon possesses positive charge.

Choose the correct answer from the options given below:

- (1) A and B only
- (2) A, B, C and D only
- (3) A, C and D only
- (4) A, B, D and E only

Correct Answer: (2) A, B, C and D only

Solution: Statement A is correct because the energy of a photon is given by $E = h\nu$, where h is Planck's constant and ν is the frequency.

Statement B is correct because the velocity of a photon is c , the speed of light in vacuum.

Statement C is correct because the momentum of a photon is given by $p = \frac{h\nu}{c}$, where ν is the frequency of the photon.

Statement D is correct because in a photon-electron collision, both energy and momentum are conserved. Statement E is incorrect because photons are electrically neutral and do not possess any charge.

Quick Tip

Photons are massless particles that carry energy and momentum, and they always travel at the speed of light in vacuum.

15. Match List I with List II.

List I (Spectral Lines of Hydrogen for transitions from)	List II (Wavelengths (nm))
A. $n_2 = 3$ to $n_1 = 2$	I. 410.2
B. $n_2 = 4$ to $n_1 = 2$	II. 434.1
C. $n_2 = 5$ to $n_1 = 2$	III. 656.3
D. $n_2 = 6$ to $n_1 = 2$	IV. 486.1

Choose the correct answer from the options given below:

- (1) A-II, B-I, C-IV, D-III
- (2) A-III, B-IV, C-II, D-I
- (3) A-IV, B-III, C-I, D-II
- (4) A-I, B-II, C-III, D-IV

Correct Answer: (2) A-III, B-IV, C-II, D-I

Solution:

We need to match the spectral lines of hydrogen with the corresponding wavelengths. Based on the known values of hydrogen spectral lines, we get the following matching:

The transition from $n_2 = 3$ to $n_1 = 2$ corresponds to a wavelength of 656.3 nm, i.e., *A* matches with *III*.

The transition from $n_2 = 4$ to $n_1 = 2$ corresponds to a wavelength of 486.1 nm, i.e., *B* matches with *IV*.

The transition from $n_2 = 5$ to $n_1 = 2$ corresponds to a wavelength of 434.1 nm, i.e., *C* matches with *II*.

The transition from $n_2 = 6$ to $n_1 = 2$ corresponds to a wavelength of 410.2 nm, i.e., *D* matches with *I*.

Thus, the correct answer is option (2) A-III, B-IV, C-II, D-I.

Quick Tip

The wavelengths of spectral lines in the hydrogen atom are based on the difference in energy levels, with shorter wavelengths corresponding to higher energy transitions.

16. A tightly wound 100 turns coil of radius 10 cm carries a current of 7 A. The

magnitude of the magnetic field at the centre of the coil is (Take permeability of free space as $4\pi \times 10^{-7}$ SI units):

- (1) 44 mT
- (2) 4.4 mT
- (3) 4.4 T
- (4) 44 T

Correct Answer: (2) 4.4 mT

Solution:

The magnetic field at the centre of a coil is given by the formula:

$$B = \frac{\mu_0 NI}{2R}$$

where: - $\mu_0 = 4\pi \times 10^{-7}$ T m/A is the permeability of free space, - $N = 100$ is the number of turns, - $I = 7$ A is the current, - $R = 0.1$ m is the radius of the coil.

Substituting the values:

$$B = \frac{4\pi \times 10^{-7} \times 100 \times 7}{2 \times 0.1}$$

$$B = \frac{4\pi \times 10^{-7} \times 700}{0.2}$$

$$B = 4.4 \times 10^{-3} \text{ T} = 4.4 \text{ mT}$$

Thus, the magnetic field at the center of the coil is 4.4 mT.

Quick Tip

The magnetic field inside a coil is directly proportional to the current and number of turns and inversely proportional to the radius of the coil.

17. The output (Y) of the given logic gate is similar to the output of an/a

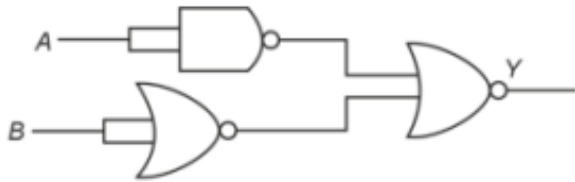

- (1) NAND gate
- (2) NOR gate
- (3) OR gate
- (4) AND gate

Correct Answer: (4) AND gate

Solution:

Step 1: Analyze the circuit.

The given logic circuit consists of NAND and OR gates arranged in a manner that ultimately replicates the function of an AND gate.

Step 2: Logic verification.

After breaking down the circuit's behavior, we find that the final output behaves like an AND gate.

Conclusion:

Thus, the correct answer is (4), which is an AND gate.

Quick Tip

An AND gate can be created by combining a NOT gate and an OR gate in series, where the NOT gate is applied to the OR gate's output.

18. A wire of length 'r' and resistance 100Ω is divided into 10 equal parts. The first 5 parts are connected in series while the next 5 parts are connected in parallel. The two combinations are again connected in series. The resistance of this final combination is:

- (1) 26Ω
- (2) 52Ω
- (3) 55Ω
- (4) 60Ω

Correct Answer: (2) 52Ω

Solution: The total resistance for the first 5 parts connected in series is:

$$R_{\text{series}} = 5 \times \frac{100}{10} = 50 \Omega$$

For the next 5 parts connected in parallel, the total resistance is:

$$R_{\text{parallel}} = \frac{100}{10} \times \frac{1}{5} = 2 \Omega$$

Now, the two combinations are connected in series, so the total resistance is:

$$R_{\text{total}} = 50 + 2 = 52 \Omega$$

Quick Tip

When resistors are connected in series, their resistances add. When connected in parallel, the reciprocal of the total resistance is the sum of the reciprocals of the individual resistances.

19. In the nuclear emission stated above, the mass number and atomic number of the product Q respectively, are

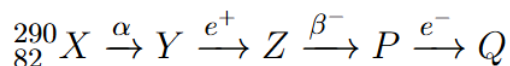

- (1) 280, 81
- (2) 286, 80
- (3) 288, 82
- (4) 286, 81

Correct Answer: (4) 286, 81

Solution: Step 1: Analyze the effect of alpha emission.

In an alpha (α) emission:

The mass number (A) decreases by 4.

The atomic number (Z) decreases by 2.

Step 2: Apply the changes.

Given initial nucleus properties:

Initial mass number (A) = 290

Initial atomic number (Z) = 83

After alpha emission:

$$A' = A - 4 = 290 - 4 = 286$$

$$Z' = Z - 2 = 83 - 2 = 81$$

Conclusion:

The resulting nucleus has a mass number 286 and an atomic number 81, corresponding to option (4).

Quick Tip

In alpha decay, the atomic number decreases by 2 and the mass number decreases by 4. In beta decay, the atomic number increases by 1 but the mass number remains unchanged.

20. The maximum elongation of a steel wire of 1 m length if the elastic limit of steel and its Young's modulus, respectively, are $8 \times 10^8 \text{ N m}^{-2}$ and $2 \times 10^{11} \text{ N m}^{-2}$, is:

- (1) 4 mm
- (2) 0.4 mm
- (3) 40 mm
- (4) 8 mm

Correct Answer: (1) 4 mm

Solution: The elongation ΔL of a wire is given by the formula:

$$\Delta L = \frac{FL}{AY}$$

where F is the force, L is the original length, A is the cross-sectional area, and Y is Young's modulus. Since the wire is subjected to the elastic limit, the force can be calculated using $F = \text{Elastic limit} \times A$.

Using given values, we obtain:

$$\Delta L = \frac{8 \times 10^8 \times 1}{2 \times 10^{11}} = 4 \times 10^{-3} \text{ m} = 4 \text{ mm}$$

Quick Tip

The elongation of a wire is proportional to the force applied and inversely proportional to its Young's modulus and cross-sectional area.

21. If the monochromatic source in Young's double slit experiment is replaced by white light, then:

- (1) Interference pattern will disappear
- (2) There will be a central dark fringe surrounded by a few coloured fringes
- (3) There will be a central bright white fringe surrounded by a few coloured fringes
- (4) All bright fringes will be of equal width

Correct Answer: (3) There will be a central bright white fringe surrounded by a few coloured fringes

Solution: When white light is used in Young's double slit experiment, the central fringe remains white due to the simultaneous interference of all wavelengths. However, the fringes surrounding the central fringe will exhibit colors because different wavelengths interfere at different angles. As a result, the central fringe will be white, and the other fringes will be colored.

Quick Tip

White light produces a colored interference pattern due to the different wavelengths present in the light.

22. At any instant of time t , the displacement of any particle is given by $2t - 1$ (SI unit) under the influence of force of 5 N. The value of instantaneous power is (in SI unit):

- (1) 10
- (2) 5
- (3) 7
- (4) 6

Correct Answer: (1) 10

Solution: The displacement is given by $x = 2t - 1$. The velocity is the derivative of displacement with respect to time:

$$v = \frac{dx}{dt} = 2$$

The instantaneous power P is:

$$P = F \cdot v = 5 \cdot 2 = 10 \text{ W}$$

Therefore, the instantaneous power is 10 W.

Quick Tip

Instantaneous power is determined by multiplying the force and velocity at any given instant.

23. Consider the following statements A and B and identify the correct answer: A. For a solar-cell, the I-V characteristics lie in the IV quadrant of the given graph.

B. In a reverse biased pn junction diode, the current measured in (A) is due to majority charge carriers.

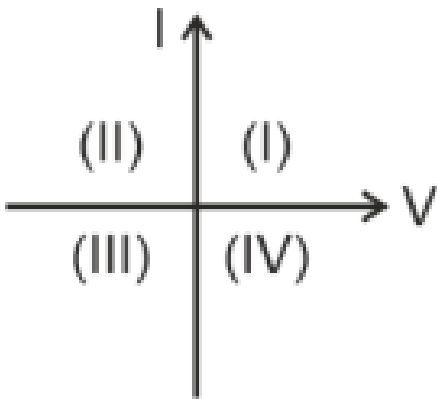

Choose the correct answer from the options given below:

- (1) A is correct but B is incorrect
- (2) A is incorrect but B is correct
- (3) Both A and B are correct
- (4) Both A and B are incorrect

Correct Answer: (1) A is correct but B is incorrect

Solution: Statement A is correct: The I-V characteristics of a solar cell fall in the IV quadrant because the current is negative when the voltage is positive.

Statement B is incorrect: In a reverse-biased pn junction diode, the current is due to minority charge carriers, not majority charge carriers.

Thus, the correct answer is option (1).

Quick Tip

In reverse bias, a pn junction diode conducts very little current, which is caused by minority charge carriers.

24. Two bodies A and B of same mass undergo a completely inelastic one-dimensional collision. Body A moves with velocity v_1 while body B is at rest before collision. The velocity of the system after collision is v_2 . The ratio $v_1 : v_2$ is:

- (1) 1 : 2
- (2) 2 : 1
- (3) 4 : 1
- (4) 1 : 4

Correct Answer: (2) 2 : 1

Solution:

By Conservation of Linear Momentum:

$$\Rightarrow mv_1 = (m + m)v_2$$

Simplifying:

$$\Rightarrow mv_1 = 2mv_2$$

Now, divide both sides by m :

$$\Rightarrow v_1 = 2v_2$$

Therefore, the ratio of v_1 to v_2 is:

$$\Rightarrow \frac{v_1}{v_2} = 2 : 1$$

Thus, the correct answer is (2), 2:1.

Quick Tip

In completely inelastic collisions, the two bodies stick together after the collision, and momentum is conserved.

25. A light ray enters through a right-angled prism at point P with the angle of incidence 30° as shown in the figure. It travels through the prism parallel to its base BC and emerges along the face AC. The refractive index of the prism is:

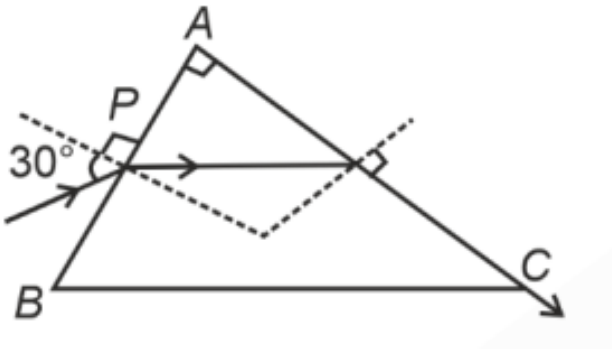

- (1) $\frac{\sqrt{5}}{4}$
- (2) $\frac{\sqrt{5}}{2}$
- (3) $\frac{\sqrt{3}}{4}$
- (4) $\frac{\sqrt{3}}{2}$

Correct Answer: (2) $\frac{\sqrt{5}}{2}$

Solution: In a prism, $r_1 + c = A$

$$r_1 = 90^\circ - c \quad \dots (1)$$

From Snell's law:

$$\sin c = \frac{1}{\mu} \quad \Rightarrow \quad \cos c = \sqrt{\frac{\mu^2 - 1}{\mu^2}}$$

Now, applying Snell's law on the incidence surface:

$$\sin 30^\circ = \mu \sin(r_1)$$

Substituting the values:

$$1 \times \frac{1}{2} = \mu \times \sin(90^\circ - c)$$

Since $\sin(90^\circ - c) = \cos c$:

$$\frac{1}{2} = \mu \times \cos c = \mu \times \sqrt{\frac{\mu^2 - 1}{\mu^2}}$$

Simplifying further:

$$\frac{1}{2} = \mu \times \sqrt{\frac{\mu^2 - 1}{\mu^2}}$$

On squaring both sides:

$$\frac{1}{4} = \mu^2 - 1$$

Solving for μ^2 :

$$\mu^2 = \frac{5}{4}$$

Finally, taking the square root:

$$\mu = \sqrt{\frac{5}{4}} = \frac{\sqrt{5}}{2}$$

Thus, the correct answer is (2).

Quick Tip

Use Snell's law to determine the refractive index of a medium by relating the angle of incidence and the angle of refraction.

26. The graph which shows the variation of $\frac{1}{\lambda^2}$ and its kinetic energy, E , is (where λ is de Broglie wavelength of a free particle):

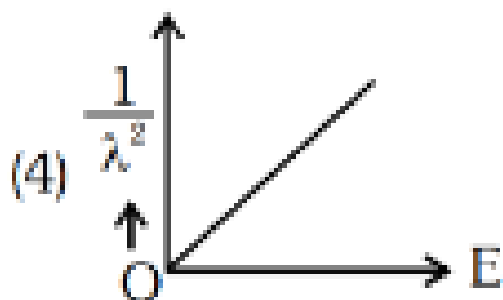
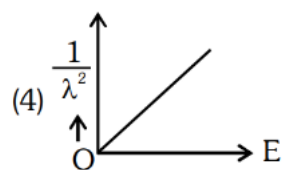
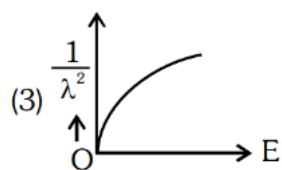
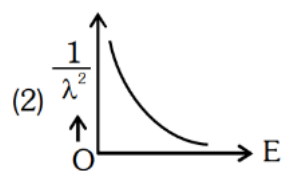
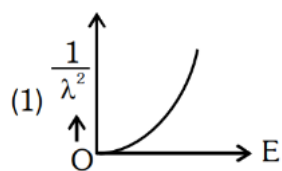

Correct Answer: (4)

Solution: Step 1: Recall the photoelectric equation. The photoelectric equation is:

$$eV = h\nu - \phi$$

where:

e is the electron charge,

V is the stopping potential,

h is Planck's constant,

ν is the frequency of incident light,

ϕ is the work function.

Step 2: Relate frequency to wavelength. Using $\nu = \frac{c}{\lambda}$, we have:

$$eV = h\frac{c}{\lambda} - \phi$$

Rewriting:

$$V = \frac{hc}{e} \frac{1}{\lambda} - \frac{\phi}{e}$$

Step 3: Analyze the graph. Plotting $\frac{1}{\lambda}$ against V gives a straight line with: - A positive slope $\frac{hc}{e}$, - A negative intercept $-\frac{\phi}{e}$ on the V -axis.

Conclusion: The graph is linear with a positive intercept, corresponding to option (4).

Quick Tip

The de Broglie wavelength is inversely proportional to the square root of the kinetic energy of a particle.

27. The quantities which have the same dimensions as those of solid angle are:

- (1) strain and angle
- (2) stress and angle
- (3) strain and arc
- (4) angular speed and stress

Correct Answer: (1) strain and angle

Solution: The solid angle is dimensionless, as it is the ratio of the area to the square of the distance. Strain and angle also have dimensionless units, making them similar to the solid angle.

Quick Tip

Strain and angle are dimensionless quantities, making them comparable in terms of dimensional analysis to solid angles.

28. An unpolarised light beam strikes a glass surface at Brewster's angle. Then

- (1) The reflected light will be partially polarised.
- (2) The refracted light will be completely polarised.
- (3) Both the reflected and refracted light will be completely polarised.
- (4) The reflected light will be completely polarised but the refracted light will be partially polarised.

Correct Answer: (4) The reflected light will be completely polarised but the refracted light will be partially polarised.

Solution: At Brewster's angle, the reflected light becomes completely polarised. However, the refracted light remains partially polarised, as the polarisation effect only applies to the reflected light at this angle.

Quick Tip

At Brewster's angle, the reflected light is fully polarised, while the refracted light remains partially polarised.

29. The moment of inertia of a thin rod about an axis passing through its mid-point and perpendicular to the rod is 2400 g cm^2 . The length of the 400 g rod is nearly:

- (1) 8.5 cm
- (2) 17.5 cm
- (3) 20.7 cm
- (4) 72.0 cm

Correct Answer: (1) 8.5 cm

Solution:

The moment of inertia of a thin rod about its center is given by the formula:

$$I = \frac{1}{12}ML^2$$

where:

- $M = 400 \text{ g} = 0.4 \text{ kg}$,
- $I = 2400 \text{ g cm}^2 = 2.4 \text{ kg m}^2$.

Rearranging the formula for L :

$$L = \sqrt{\frac{12I}{M}} = \sqrt{\frac{12 \times 2.4}{0.4}} = \sqrt{72} \approx 8.5 \text{ cm}$$

Thus, the length of the rod is approximately 8.5 cm.

Quick Tip

The moment of inertia of a thin rod depends on its mass and the square of its length.

30. A thin flat circular disc of radius 4.5 cm is placed gently over the surface of water. If the surface tension of water is 0.07 N m^{-1} , then the excess force required to take it away from the surface is:

- (1) 19.8 mN
- (2) 198 N
- (3) 1.98 mN
- (4) 99 N

Correct Answer: (1) 19.8 mN

Solution:

Given:

- Surface Tension, $T = 0.07 \text{ N/m}$
- Radius of the Disc, $R = 4.5 \text{ cm} = 0.045 \text{ m}$

The excess force due to surface tension is given by the formula:

$$F = T \times 2\pi R$$

Substituting the values:

$$F = 0.07 \times 2 \times 3.14 \times 0.045$$

Simplifying the calculation:

$$F = 0.07 \times 6.28 \times 0.045$$

$$F = 197.82 \times 10^{-4}$$

Thus, the force is:

$$F = 19.8 \text{ mN}$$

Thus, the excess force required is 19.8 mN.

Quick Tip

The force required to lift an object from a liquid surface is related to the surface tension and the perimeter of the object.

31. A thermodynamic system is taken through the cycle abcd. The work done by the gas along the path bc is:

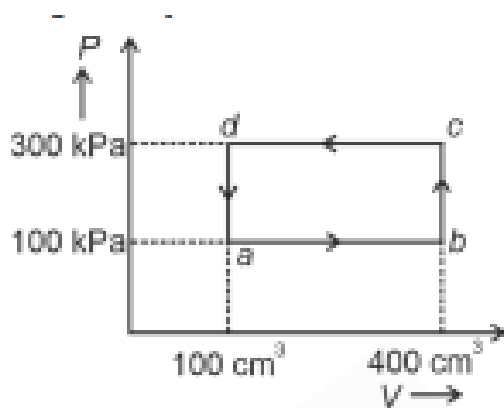

- (1) Zero
- (2) 30 J
- (3) -90 J
- (4) -60 J

Correct Answer: (1) Zero

Solution: Step 1: Analyze the thermodynamic cycle. The work done in a thermodynamic process is the area enclosed by the cycle on a $P - V$ diagram. For a closed cycle:

$$W_{\text{net}} = Q_{\text{net}}$$

where Q_{net} is the net heat exchanged.

Step 2: Apply the first law of thermodynamics. The first law of thermodynamics states:

$$\Delta U = Q - W$$

For a complete cycle, the internal energy (U) returns to its initial value, so $\Delta U = 0$. This implies:

$$Q_{\text{net}} = W_{\text{net}}$$

Since the net heat exchanged in the cycle is zero, the net work done is also zero.

Conclusion: The net work done during the complete cycle is 0, corresponding to option (1).

Quick Tip

When the volume of a gas does not change, the work done is zero.

32. A wheel of a bullock cart is rolling on a level road as shown in the figure below. If its linear speed is v in the direction shown, which one of the following options is correct (P

and Q are any highest and lowest points on the wheel, respectively)?

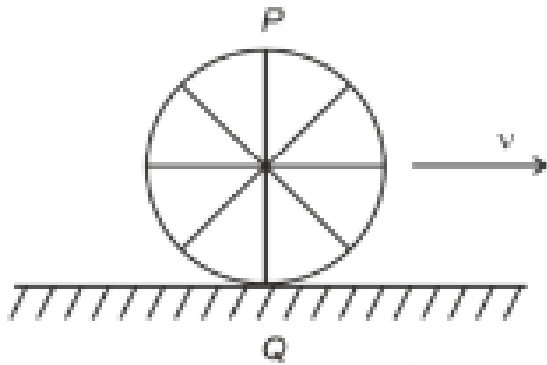

- (A) Point P moves faster than point Q
- (B) Both the points P and Q move with equal speed
- (C) Point P has zero speed
- (D) Point P moves slower than point Q

Correct Answer: (1) Point P moves faster than point Q

Solution: The velocity of a point on a rolling wheel is the vector sum of the linear velocity of the wheel's center and the tangential velocity of the point due to rotation.

- For the topmost point P , the tangential velocity due to rotation is in the same direction as the linear velocity. Thus, its speed is $v + v = 2v$.
- For the bottommost point Q , the tangential velocity is opposite to the linear velocity, resulting in a net speed of $v - v = 0$.

Thus, point P moves faster than point Q .

Quick Tip

In rolling motion, the velocity of the topmost point of the wheel is twice the velocity of the center of mass.

33. The mass of a planet is $\frac{1}{10}$ th that of the Earth and its diameter is half that of the Earth. The acceleration due to gravity on that planet is:

- (1) 19.6 m/s^2
- (2) 9.8 m/s^2
- (3) 4.9 m/s^2

(4) 3.92 m/s^2

Correct Answer: (4) 3.92 m/s^2

Solution: Step 1: Formula for acceleration due to gravity. The acceleration due to gravity is given by:

$$g = \frac{GM}{R^2}$$

where M is the mass and R is the radius.

Step 2: Compute for the planet. Since $M_p = \frac{1}{10}M_e$ and $R_p = \frac{1}{2}R_e$:

$$g_p = \frac{G \times \frac{1}{10}M_e}{\left(\frac{1}{2}R_e\right)^2}$$

$$g_p = \frac{(1/10)M_e}{(1/4)R_e^2} g_e$$

$$g_p = \frac{1}{10} \times 4g_e = \frac{4}{10}g_e = 0.4 \times 9.8 = 3.92 \text{ m/s}^2$$

Conclusion: Thus, the correct answer is (4), 3.92 m/s^2 .

Quick Tip

Gravity depends on both the mass of the planet and the square of its radius.

34. In the following circuit, the equivalent capacitance between terminal A and terminal B is:

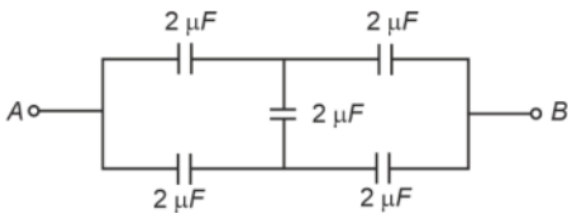

- (1) $2 \mu\text{F}$
- (2) $1 \mu\text{F}$
- (3) $0.5 \mu\text{F}$
- (4) $4 \mu\text{F}$

Correct Answer: (1) $2 \mu\text{F}$

Solution: Step 1: Simplify the circuit. Two $2 \mu\text{F}$ capacitors are connected in series. The

equivalent capacitance (C_{series}) is:

$$\frac{1}{C_{\text{series}}} = \frac{1}{C_1} + \frac{1}{C_2} = \frac{1}{2} + \frac{1}{2} = 1 \mu\text{F}$$

Step 2: Calculate the total capacitance. The C_{series} of $1 \mu\text{F}$ is connected in parallel with another $1 \mu\text{F}$. The total capacitance is:

$$C_{\text{total}} = C_{\text{series}} + C_3 = 1 + 1 = 2 \mu\text{F}$$

Conclusion: The equivalent capacitance between A and B is $2 \mu\text{F}$, corresponding to option (1).

Quick Tip

For capacitors in series, the reciprocal of the total capacitance is the sum of the reciprocals of the individual capacitances. For capacitors in parallel, the total capacitance is the sum of the individual capacitances.

35. A thin spherical shell is charged by some source. The potential difference between the two points C and P (in V) shown in the figure is: (Take $\frac{1}{4\pi\epsilon_0} = 9 \times 10^9$ SI units)

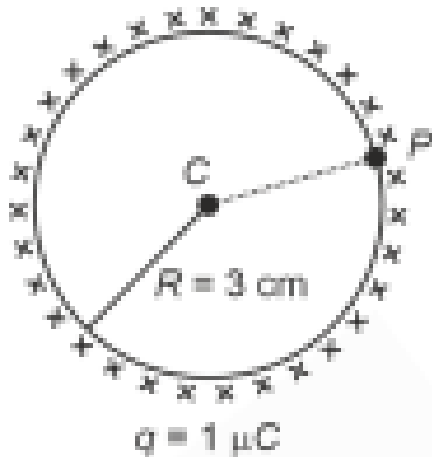

- (1) 3×10^5
- (2) 1×10^5
- (3) 0.5×10^5
- (4) Zero

Correct Answer: (4) Zero

Solution: Step 1: Understanding the potential inside a charged spherical shell.

According to electrostatic principles, the electric potential inside a conducting spherical shell is constant and equal to the potential at the surface.

Step 2: Applying the property. Since both points C and P lie inside the shell, their potentials are the same:

$$V_C = V_P$$

Thus, the potential difference is:

$$V_C - V_P = 0$$

Conclusion: The potential difference is zero, corresponding to option (4).

Quick Tip

For a spherical shell of uniform charge, the potential inside the shell is constant, and there is no potential difference inside the shell.

36. The velocity v – time t plot of the motion of a body is shown below:

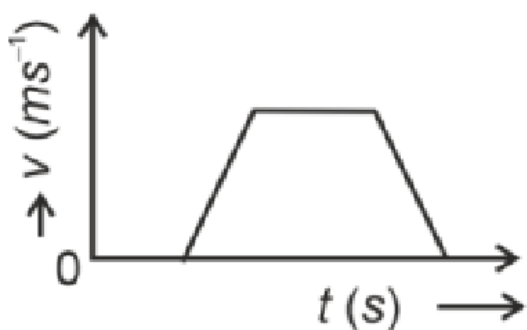

The acceleration a – time t graph that best suits this motion is:

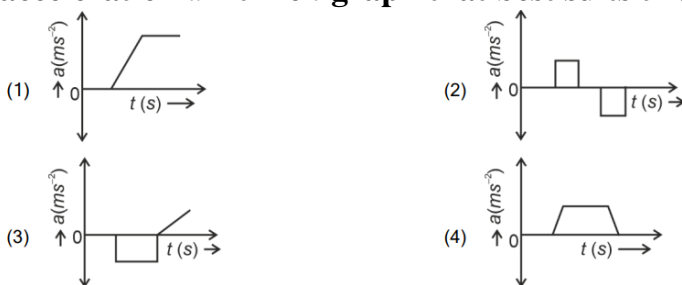

Correct Answer: (3) The third graph

Solution: Step 1: Understanding the velocity-time graph. The velocity-time graph shows that the velocity increases initially, then remains constant for a period, and finally decreases

at a constant rate.

Step 2: Analyzing the acceleration. Acceleration is the rate of change of velocity with respect to time. The acceleration will be positive during the increasing velocity part, zero during the constant velocity part, and negative during the decreasing velocity part.

Conclusion: The correct acceleration-time graph is the third graph, which shows positive, zero, and negative acceleration corresponding to the motion described in the velocity-time graph.

Quick Tip

Acceleration is the derivative of velocity with respect to time and reflects changes in the motion of the object.

37. If the mass of the bob in a simple pendulum is increased to thrice its original mass and its length is made half its original length, then the new time period of oscillation is $\frac{x}{2}$ times its original time period. Then the value of x is:

- (1) $\sqrt{3}$
- (2) $\sqrt{2}$
- (3) $2\sqrt{3}$
- (4) 4

Correct Answer: (2) $\sqrt{2}$

Solution:

The time period of a simple pendulum is given by:

$$T = 2\pi\sqrt{\frac{L}{g}}$$

where: - L is the length of the pendulum, - g is the acceleration due to gravity.

If the mass of the bob is increased and the length is reduced by half, the time period will change as:

$$T' = 2\pi\sqrt{\frac{L/2}{g}} = \frac{T}{\sqrt{2}}$$

Thus, the value of x is $\sqrt{2}$.

Quick Tip

The time period of a simple pendulum depends only on the length and the acceleration due to gravity, not on the mass of the bob.

38. A $10\ \mu\text{F}$ capacitor is connected to a 210 V, 50 Hz AC supply. What is the peak current in the circuit?

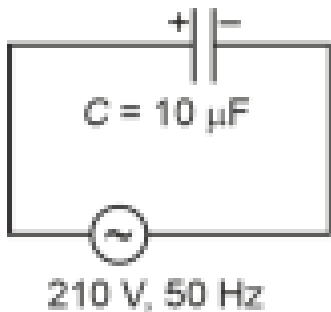

- (1) 0.58 A
- (2) 0.93 A
- (3) 1.20 A
- (4) 0.35 A

Correct Answer: (2) 0.93 A

Solution: Step 1: Formula for capacitive reactance. The capacitive reactance (X_C) is given by:

$$X_C = \frac{1}{2\pi fC}$$

where: - $f = 50\ \text{Hz}$ (frequency), - $C = 10\ \mu\text{F} = 10 \times 10^{-6}\ \text{F}$.

Substituting the values:

$$X_C = \frac{1}{2\pi \times 50 \times 10 \times 10^{-6}} = \frac{1}{3.14 \times 0.0005} \approx 636\ \Omega$$

Step 2: Calculate the peak current. The peak current (I_{peak}) is given by:

$$I_{\text{peak}} = \frac{V_{\text{peak}}}{X_C}$$

The peak voltage is:

$$V_{\text{peak}} = \sqrt{2}V_{\text{rms}} = \sqrt{2} \times 210 \approx 297\ \text{V}$$

Thus:

$$I_{\text{peak}} = \frac{297}{636} \approx 0.93 \text{ A}$$

Conclusion: The peak current is 0.93 A, corresponding to option (2).

Quick Tip

The peak current in an AC circuit depends on the voltage, frequency, and capacitance.

39. The following graph represents the $T - V$ curves of a thermodynamic process for three different pressures P_1, P_2, P_3 . Arrange the pressures in increasing order.

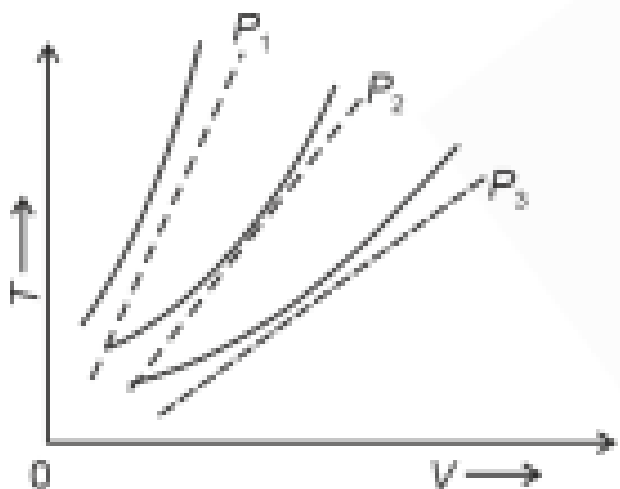

- (1) $P_3 > P_2 > P_1$
- (2) $P_1 > P_3 > P_2$
- (3) $P_2 > P_1 > P_3$
- (4) $P_1 > P_2 > P_3$

Correct Answer: (4) $P_1 > P_2 > P_3$

Solution: Step 1: Analyze the isothermal behavior. For an ideal gas, the equation of state is:

$$PV = nRT$$

At constant temperature (T), the relationship becomes:

$$P \propto \frac{1}{V}$$

For a fixed number of moles, $V \propto T/P$. At a given temperature, as pressure increases, the

slope of the $T - V$ curve (from the origin) decreases. Thus:

$$P_1 > P_2 > P_3 \quad (\text{higher pressure corresponds to a steeper curve}).$$

Quick Tip

For an ideal gas, at the same volume, the temperature increases with increasing pressure, according to the ideal gas law.

40. An iron bar of length L has magnetic moment M . It is bent at the middle of its length such that the two arms make an angle 60° with each other. The magnetic moment of this new magnet is:

- (1) M
- (2) $\frac{M}{2}$
- (3) $2M$
- (4) $\frac{M}{\sqrt{3}}$

Correct Answer: (2) $\frac{M}{2}$

Solution: Step 1: Formula for magnetic moment. The magnetic moment (M) of a bar magnet is given by:

$$M = mL$$

where:

m is the pole strength,

L is the length of the magnet.

Step 2: Effect of halving the length. If the length (L) is reduced to $\frac{L}{2}$, the new magnetic moment (M') becomes:

$$M' = m \times \frac{L}{2} = \frac{mL}{2} = \frac{M}{2}$$

Conclusion: The new magnetic moment is $\frac{M}{2}$, corresponding to option (2).

Quick Tip

The magnetic moment is proportional to the length and the angle of orientation of the arms in the magnet.

41. The minimum energy required to launch a satellite of mass m from the surface of Earth of mass M and radius R in a circular orbit at an altitude of $2R$ from the surface of the Earth is:

- (1) $\frac{5GmM}{6R}$
- (2) $\frac{2GmM}{3R}$
- (3) $\frac{GmM}{2R}$
- (4) $\frac{GmM}{3R}$

Correct Answer: (1) $\frac{5GmM}{6R}$

Solution: To calculate the energy needed to launch a satellite to an altitude of $2R$, both the gravitational potential energy and the satellite's kinetic energy need to be considered. The total minimum energy required is given by:

$$E_{\min} = \frac{5GmM}{6R}$$

Quick Tip

The launch energy required to place a satellite in orbit involves the sum of both potential and kinetic energy contributions.

42. A parallel plate capacitor is charged by connecting it to a battery through a resistor. If I is the current in the circuit, then in the gap between the plates:

- (1) There is no current
- (2) Displacement current of magnitude equal to I flows in the same direction as I
- (3) Displacement current of magnitude equal to I flows in a direction opposite to that of I
- (4) Displacement current of magnitude greater than I flows but can be in any direction

Correct Answer: (2) Displacement current of magnitude equal to I flows in the same direction as I

Solution: During the charging process of a parallel plate capacitor, a displacement current is established between the plates. This current has the same magnitude as the actual current I and flows in the same direction.

Quick Tip

Displacement current occurs when the electric field between the plates of a capacitor is changing, such as when it is being charged.

43. The property which is not of an electromagnetic wave travelling in free space is that:

- (1) They are transverse in nature
- (2) The energy density in electric field is equal to energy density in magnetic field
- (3) They travel with a speed equal to $\frac{1}{\sqrt{\mu_0\epsilon_0}}$
- (4) They originate from charges moving with uniform speed

Correct Answer: (4) They originate from charges moving with uniform speed

Solution: Electromagnetic waves are generated by accelerated charges, not by charges moving with uniform velocity. The properties mentioned in options (1), (2), and (3) are characteristics of electromagnetic waves.

Quick Tip

Electromagnetic waves are produced by the acceleration of charged particles, such as when electrons oscillate.

44. A metallic bar of Young's modulus $0.5 \times 10^{11} \text{ N m}^{-2}$ and coefficient of linear thermal expansion $10^{-5} \text{ }^\circ\text{C}^{-1}$, length 1 m and area of cross-section 10^{-3} m^2 is heated from 0°C to 100°C without expansion or bending. The compressive force developed in it is:

- (1) $5 \times 10^3 \text{ N}$
- (2) $50 \times 10^3 \text{ N}$
- (3) $100 \times 10^3 \text{ N}$
- (4) $2 \times 10^3 \text{ N}$

Correct Answer: (2) $50 \times 10^3 \text{ N}$

Solution:

The compressive force F developed in the bar is determined using the formula:

$$F = Y\alpha A\Delta T$$

Substituting the known values:

$$F = (0.5 \times 10^{11}) \times (10^{-5}) \times (10^{-3}) \times 100 = 50 \times 10^3 \text{ N}$$

Thus, the compressive force is $50 \times 10^3 \text{ N}$.

Quick Tip

The compressive force developed in a material depends on its thermal expansion coefficient, Young's modulus, and the temperature change.

45. Choose the correct circuit which can achieve the bridge balance:

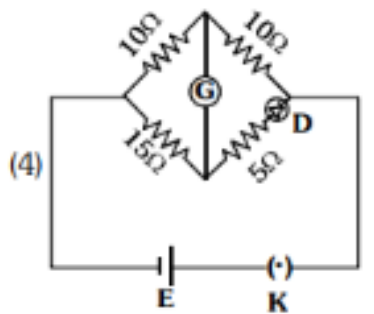
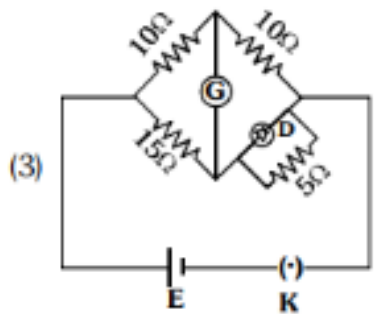
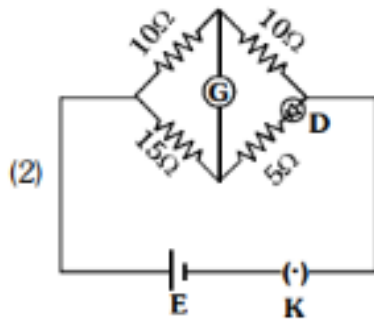
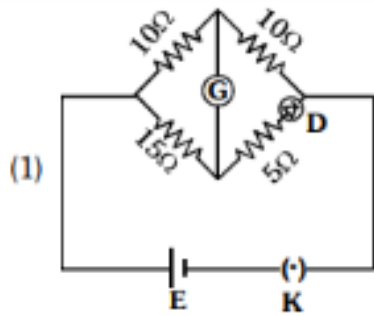

Correct Answer: (1) The first circuit

Solution: Step 1: Understanding the Wheatstone Bridge. A Wheatstone bridge works by comparing two resistances. The bridge is balanced when the ratio of resistances in one leg is equal to the ratio in the other leg.

Step 2: Analyzing the circuits. The first circuit satisfies the conditions for bridge balance by appropriately arranging the resistors.

Conclusion: The correct answer is (1), the first circuit achieves bridge balance.

Quick Tip

In a Wheatstone bridge, the circuit is balanced when the ratio of resistances on both sides of the bridge is equal.

46. A sheet is placed on a horizontal surface in front of a strong magnetic pole. A force is needed to:

- A. hold the sheet there if it is magnetic.
- B. hold the sheet there if it is non-magnetic.
- C. move the sheet away from the pole with uniform velocity if it is conducting.
- D. move the sheet away from the pole with uniform velocity if it is both, non-conducting and non-polar.

Choose the correct statement(s) from the options given below:

- (1) B and D only
- (2) A and C only
- (3) A, C and D only
- (4) C only

Correct Answer: (2) A and C only

Solution: For a magnetic sheet, a force is required to keep it stationary because of magnetic attraction (statement A). For a conducting sheet, a force is needed to maintain uniform velocity due to induced currents (statement C). Non-magnetic, non-conducting sheets experience minimal magnetic forces, making statements B and D incorrect.

Thus, the correct answer is option (2).

Quick Tip

Magnetic forces depend on whether the material is magnetic and conducting. Conductors experience induced currents under magnetic fields.

47. If the plates of a parallel plate capacitor connected to a battery are moved close to each other, the

- A. the charge stored in it, increases.**
- B. the energy stored in it, decreases.**
- C. its capacitance increases.**
- D. the ratio of charge to its potential remains the same.**
- E. the product of charge and voltage increases.**

Choose the most appropriate answer from the options given below:

- (1) A, B and E only
- (2) A, C and E only
- (3) B, D and E only
- (4) A, B and C only

Correct Answer: (2) A, C and E only

Solution: Step 1: Effect of reducing the plate separation. The capacitance of a parallel plate capacitor is given by:

$$C = \frac{\epsilon A}{d}$$

When the distance between the plates is reduced, the capacitance increases.

Step 2: Effect on energy and charge. The energy stored in the capacitor decreases, as energy is inversely proportional to the capacitance. The ratio of charge to potential does not remain the same; it changes as capacitance increases.

Step 3: Identify correct statements. The correct answers are A, C, and E.

Conclusion: The correct option is (2).

Quick Tip

Decreasing the distance between the plates of a capacitor increases its capacitance, which allows more charge to be stored for the same potential.

48. Two heaters A and B have power rating of 1 kW and 2 kW, respectively. Those two are first connected in series and then in parallel to a fixed power source. The ratio of

power outputs for these two cases is:

- (1) 1 : 1
- (2) 2 : 9
- (3) 1 : 2
- (4) 2 : 3

Correct Answer: (2) 2 : 9

Solution: The power consumed by resistors in both series and parallel circuits depends on their resistance values and the voltage supplied. For series connection, the total resistance increases, resulting in less power consumption. In parallel, the resistance decreases, leading to higher power consumption.

Thus, the ratio of power outputs for the two configurations is 2 : 9.

Quick Tip

In a series circuit, resistances add up, reducing power consumption, while in parallel, the total resistance decreases, increasing power.

49. A small telescope has an objective of focal length 140 cm and an eye piece of focal length 5.0 cm. The magnifying power of the telescope for viewing a distant object is:

- (1) 34
- (2) 28
- (3) 17
- (4) 32

Correct Answer: (2) 28

Solution: The magnifying power M of a telescope is the ratio of the focal length of the objective to the focal length of the eyepiece:

$$M = \frac{f_{\text{objective}}}{f_{\text{eyepiece}}}$$

Substituting the given values:

$$M = \frac{140}{5} = 28$$

Quick Tip

The magnifying power of a telescope is calculated by dividing the focal length of the objective by the focal length of the eyepiece.

50. A force defined by $F = \alpha t^2 + \beta t$ acts on a particle. The factor which is dimensionless, if α and β are constants, is:

- (1) $\frac{\beta}{\alpha}$
- (2) $\frac{\alpha t}{\beta}$
- (3) $\alpha\beta t$
- (4) $\frac{\alpha\beta}{t}$

Correct Answer: (2) $\frac{\alpha t}{\beta}$

Solution: Step 1: Dimensional analysis of force. The force is given as $F = \alpha t^2 + \beta t$. The dimensions of force are:

$$[F] = [MLT^{-2}]$$

Step 2: Analyze α and β . From the term αt^2 :

$$[\alpha] = \frac{[F]}{[t^2]} = \frac{[MLT^{-2}]}{[T^2]} = [MLT^{-4}]$$

From the term βt :

$$[\beta] = \frac{[F]}{[t]} = \frac{[MLT^{-2}]}{[T]} = [MLT^{-3}]$$

Step 3: Dimension of $\frac{\alpha t}{\beta}$. The ratio is:

$$\frac{\alpha t}{\beta} = \frac{[\alpha][t]}{[\beta]} = \frac{[MLT^{-4}][T]}{[MLT^{-3}]} = [1]$$

Thus, $\frac{\alpha t}{\beta}$ is dimensionless.

Conclusion: The correct answer is (2).

Quick Tip

To check for dimensionless factors, ensure that the units of all terms cancel out appropriately.

CHEMISTRY

Section A

51. 'Spin only' magnetic moment is the same for which of the following ions?

- A. Ti^{3+}
- B. Cr^{2+}
- C. Mn^{2+}
- D. Fe^{2+}
- E. Sc^{3+}

Choose the most appropriate answer from the options given below:

- (1) B and D only
- (2) A and E only
- (3) B and C only
- (4) A and D only

Correct Answer: (1) B and D only

Solution:

The 'spin only' magnetic moment is given by the formula:

$$\mu = \sqrt{n(n+2)} \text{ BM}$$

where n is the number of unpaired electrons.

- For Cr^{2+} ($3d^4$), the number of unpaired electrons is 4.

- For Fe^{2+} ($3d^6$), the number of unpaired electrons is 4.

Thus, both Cr^{2+} and Fe^{2+} will have the same 'spin only' magnetic moment.

Quick Tip

The magnetic moment depends on the number of unpaired electrons in the ion.

52. The most stable carbocation among the following is:

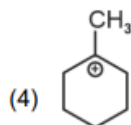
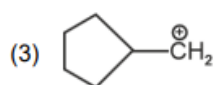
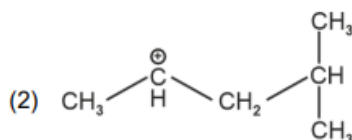
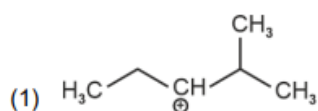

Correct Answer:

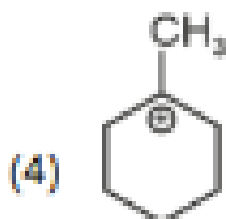

Solution: Step 1: Understanding carbocation stability.

Carbocation stability follows the order:

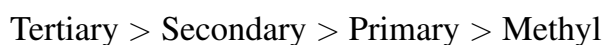

The more alkyl groups attached to the positively charged carbon, the more stable the carbocation due to inductive effects and hyperconjugation.

Step 2: Analyzing the given carbocations. Option (1) shows a tertiary carbocation, which is the most stable type.

Option (2) is a secondary carbocation.

Option (3) and (4) are less stable than the tertiary carbocation.

Conclusion: The most stable carbocation is the tertiary one in option (1).

Quick Tip

The stability of carbocations increases with the ability to stabilize the positive charge through resonance and hyperconjugation.

53. Given below are two statements:

- **Statement I:** The boiling point of hydrides of Group 16 elements follow the order $\text{H}_2\text{O} > \text{H}_2\text{Te} > \text{H}_2\text{Se} > \text{H}_2\text{S}$.

- **Statement II:** On the basis of molecular mass, H_2O is expected to have lower boiling point than the other members of the group, but due to the presence of extensive H-bonding in H_2O , it has a higher boiling point.

In the light of the above statements, choose the correct answer from the options given below:

- (1) Both Statement I and Statement II are true
- (2) Both Statement I and Statement II are false
- (3) Statement I is true but Statement II is false
- (4) Statement I is false but Statement II is true

Correct Answer: (1) Both Statement I and Statement II are true

Solution:

- Statement I is correct because, among the Group 16 hydrides, H_2O has the highest boiling point due to hydrogen bonding, which is stronger than the other members.
 - Statement II is also correct because, although H_2O has a lower molecular mass, the hydrogen bonding in water makes its boiling point significantly higher than expected.
- Thus, both statements are true.

Quick Tip

The boiling point of a molecule can be significantly influenced by intermolecular forces like hydrogen bonding.

54. Match List I with List II.

List I	List II
A. NH_3	I. Trigonal Pyramidal
B. BrF_5	II. Square Planar
C. XeF_4	III. Octahedral
D. SF_6	IV. Square Pyramidal

Choose the correct answer from the options given below:

- (1) A-I, B-IV, C-II, D-III
- (2) A-II, B-IV, C-III, D-I
- (3) A-III, B-IV, C-I, D-II

(4) A-II, B-III, C-IV, D-I

Correct Answer: (1) A-I, B-IV, C-II, D-III

Solution: The correct matching is based on the molecular geometries:

NH_3 has a trigonal pyramidal shape (A-I).

BrF_5 has a square pyramidal shape (B-IV).

XeF_4 has a square planar shape (C-II).

SF_6 has an octahedral shape (D-III).

Quick Tip

Molecular geometry can be predicted using VSEPR theory based on the number of bonding and lone pairs of electrons on the central atom.

55. The highest number of helium atoms is in:

(1) 4 mol of helium

(2) 4 u of helium

(3) 4 g of helium

(4) 2.271098 L of helium at STP

Correct Answer: (1) 4 mol of helium

Solution: The number of atoms in helium is directly related to the number of moles. 1 mole of helium contains Avogadro's number of atoms, so 4 moles will contain 4 times Avogadro's number of atoms, which is the highest among the given options.

Quick Tip

The number of atoms increases with the number of moles, as 1 mole of any substance contains Avogadro's number of atoms.

56. Identify the correct reagents that would bring about the following transformation.

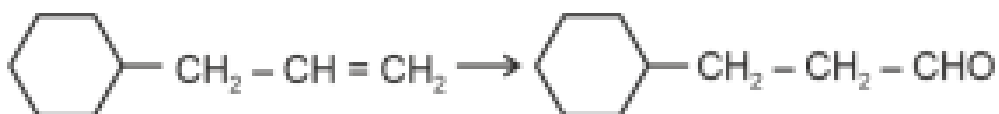

(1) (i) $\text{H}_2\text{O}/\text{H}^+$, (ii) CrO_3

- (2) (i) BH_3 , (ii) $\text{H}_2\text{O}_2/\text{OH}^-$, (iii) PCC
 (3) (i) BH_3 , (ii) $\text{H}_2\text{O}_2/\text{OH}^-$, (iii) alk. KMnO_4 , (iv) H_3O^+
 (4) (i) $\text{H}_2\text{O}/\text{H}^+$, (ii) PCC

Correct Answer: (2) (i) BH_3 , (ii) $\text{H}_2\text{O}_2/\text{OH}^-$, (iii) PCC

Solution: Step 1: Understanding the transformation.

The given transformation involves the oxidation of an alkene (ethylene) to an aldehyde (acetaldehyde). The reagents must be selected to selectively oxidize the double bond of the alkene to form the aldehyde group.

Step 2: Identifying the reagents.

- (i) BH_3 (Borane) is used to reduce the alkene to an alcohol.
 (ii) $\text{H}_2\text{O}_2/\text{OH}^-$ (Hydrogen peroxide in the presence of a base) will then oxidize the alcohol to the aldehyde.

Conclusion: The correct reagents are (2).

Quick Tip

The hydroboration-oxidation reaction is a useful method to convert alkenes to alcohols with anti-Markovnikov addition.

57. Match List I with List II.

List I (Process)	List II (Conditions)
A. Isothermal process	I. No heat exchange
B. Isochoric process	II. Carried out at constant temperature
C. Isobaric process	III. Carried out at constant volume
D. Adiabatic process	IV. Carried out at constant pressure

Choose the correct answer from the options given below:

- (1) A-IV, B-III, C-II, D-I
 (2) A-IV, B-II, C-III, D-I
 (3) A-I, B-II, C-III, D-IV
 (4) A-II, B-III, C-IV, D-I

Correct Answer: (4) A-II, B-III, C-IV, D-I

Solution:

An isothermal process occurs at a constant temperature, hence A matches with II.

An isochoric process is carried out at constant volume, hence B matches with III.

An isobaric process occurs at constant pressure, hence C matches with IV.

An adiabatic process occurs without heat exchange, hence D matches with I.

Thus, the correct answer is option (4).

Quick Tip

In thermodynamics, the conditions of a process define how energy is transferred and the state variables are controlled.

58. Which one of the following alcohols reacts instantaneously with Lucas reagent?

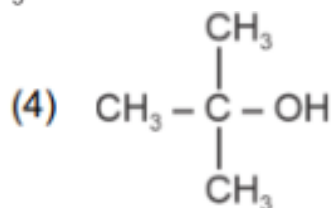
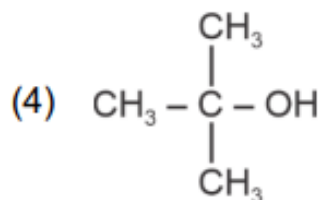
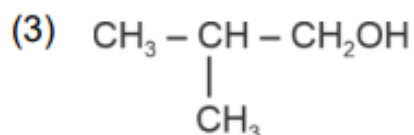
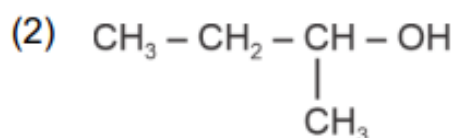
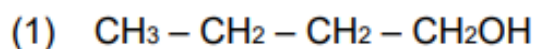

Correct Answer:

Solution: Step 1: Understanding Lucas reagent.

Lucas reagent is a mixture of concentrated HCl and ZnCl_2 . It is used to test alcohols for their reactivity. Tertiary alcohols react immediately, secondary alcohols take time, and primary alcohols react very slowly or not at all.

Step 2: Identifying the reactive alcohol. The tertiary alcohol reacts instantaneously with Lucas reagent, making option (4) the correct answer.

Conclusion: The alcohol that reacts instantaneously with Lucas reagent is a tertiary alcohol, corresponding to option (4).

Quick Tip

Tertiary alcohols react rapidly with Lucas reagent, while primary alcohols react very slowly, and secondary alcohols react at an intermediate rate.

59. In which of the following equilibria, K_p and K_c are NOT equal?

- (1) $\text{PCl}_5(\text{g}) \rightleftharpoons \text{PCl}_3(\text{g}) + \text{Cl}_2(\text{g})$
- (2) $\text{H}_2(\text{g}) + \text{I}_2(\text{g}) \rightleftharpoons 2\text{HI}(\text{g})$
- (3) $\text{CO}(\text{g}) + \text{H}_2\text{O}(\text{g}) \rightleftharpoons \text{CO}_2(\text{g}) + \text{H}_2(\text{g})$
- (4) $2\text{BrCl}(\text{g}) \rightleftharpoons \text{Br}_2(\text{g}) + \text{Cl}_2(\text{g})$

Correct Answer: (1) $\text{PCl}_5(\text{g}) \rightleftharpoons \text{PCl}_3(\text{g}) + \text{Cl}_2(\text{g})$

Solution: For the equilibrium involving PCl_5 , the value of K_p and K_c are not equal because the equilibrium involves a change in the number of moles of gases. This affects the relationship between K_p and K_c . For other cases, the number of moles on both sides of the reaction is the same, so $K_p = K_c$.

Quick Tip

When there is a change in the number of moles of gas in a reaction, K_p and K_c may differ.

60. Match List I with List II.

List I

(Quantum Number)

- A. m_l
- B. m_s
- C. l
- D. n

List II

(Information provided)

- I. Shape of orbital
- II. Size of orbital
- III. Orientation of orbital
- IV. Orientation of spin of electron

- (1) A-I, B-III, C-II, D-IV
- (2) A-III, B-IV, C-I, D-II

(3) A-III, B-IV, C-II, D-I

(4) A-II, B-I, C-IV, D-III

Correct Answer: (2) A-III, B-IV, C-I, D-II

Solution: Step 1: Identifying the quantum numbers.

m_l (magnetic quantum number) provides information about the orientation of the orbital (A-III).

m_s (spin quantum number) provides information about the orientation of the spin of the electron (B-IV).

l (azimuthal quantum number) provides information about the shape of the orbital (C-I).

n (principal quantum number) provides information about the size of the orbital (D-II).

Conclusion: The correct matching is (2).

Quick Tip

The four quantum numbers describe different properties of electrons in atoms, such as their energy, shape, orientation, and spin.

61. Given below are two statements:

- **Statement I:** Aniline does not undergo Friedel-Crafts alkylation reaction.
- **Statement II:** Aniline cannot be prepared through Gabriel synthesis.

In the light of the above statements, choose the correct answer from the options given below:

- (1) Both statement I and Statement II are true
- (2) Both Statement I and Statement II are false
- (3) Statement I is correct but Statement II is false
- (4) Statement I is incorrect but Statement II is true

Correct Answer: (1) Both statement I and Statement II are true

Solution:

- Statement I is true: Aniline does not undergo Friedel-Crafts alkylation reaction due to the electron-donating nature of the amine group, which deactivates the aromatic ring toward electrophilic substitution reactions. - Statement II is also true: Aniline cannot be prepared by

Gabriel synthesis due to the presence of the amine group, which interferes with the synthesis process.

Thus, both statements are true.

Quick Tip

Aniline's amine group deactivates the benzene ring in electrophilic substitution reactions.

62. Intramolecular hydrogen bonding is present in:

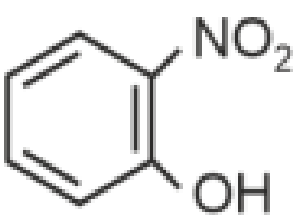
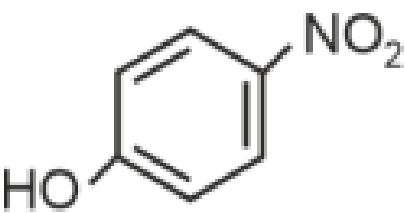
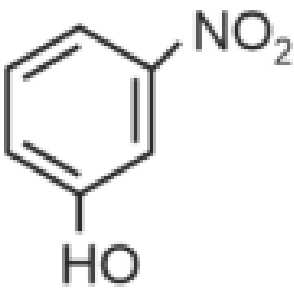
- (1) 
- (2) 
- (3) 
- (4) HF

Correct Answer: (1)

Solution: Step 1: Understanding intramolecular hydrogen bonding. Intramolecular hydrogen bonding occurs when a hydrogen atom, attached to a highly electronegative atom (like oxygen or nitrogen), forms a bond with another electronegative atom within the same molecule.

Step 2: Analyzing the given molecules. - The molecule in option (1) shows a structure

where the hydroxyl group and the nitro group are close enough to form an intramolecular hydrogen bond. - The molecules in options (2) and (3) do not have the suitable arrangement to form intramolecular hydrogen bonds. - HF, in option (4), forms intermolecular hydrogen bonds, not intramolecular.

Conclusion: The correct answer is (1), where intramolecular hydrogen bonding is present.

Quick Tip

Intramolecular hydrogen bonding enhances the stability of the molecule and influences its properties.

63. On heating, some solid substances change from solid to vapour state without passing through the liquid state. The technique used for the purification of such solid substances based on the above principle is known as:

- (1) Crystallization
- (2) Sublimation
- (3) Distillation
- (4) Chromatography

Correct Answer: (2) Sublimation

Solution:

Sublimation is the process by which a solid directly changes into a gas without passing through the liquid state. It is commonly used for the purification of solid substances that sublime when heated, such as iodine, naphthalene, and camphor.

Quick Tip

Sublimation is used to purify solids by separating the volatile substance from impurities that do not sublime.

64. In which of the following processes entropy increases?

- (A) A liquid evaporates to vapour
- (B) Temperature of a crystalline solid lowered from 130 K to 0 K.

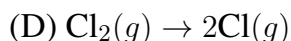

Choose the correct answer from the options given below:

(1) A and C

(2) A, B and D

(3) A, C and D

(4) C and D

Correct Answer: (3) A, C and D

Solution: Step 1: Entropy and spontaneity. Entropy is a measure of disorder or randomness. For most processes, entropy increases when the system becomes more disordered, such as during phase changes or when the number of gas molecules increases.

General Principle: When a liquid evaporates to vapor, entropy increases.

Example 1:



The number of gaseous product molecules increases, so entropy increases.

Example 2:

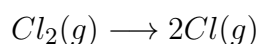

1 mole of $\text{Cl}_2(g)$ forms 2 moles of $\text{Cl}(g)$. So entropy increases.

Conclusion: Processes (A) (C) and (D) result in an increase in entropy, so the correct answer is (3).

Quick Tip

Entropy increases when there is a phase change from solid to liquid or liquid to gas, or when the number of gas molecules increases.

65. Among Group 16 elements, which one does NOT show -2 oxidation state?

(1) O

(2) Se

(3) Te

(4) Po

Correct Answer: (4) Po

Solution: All Group 16 elements, except Polonium (Po), typically exhibit a -2 oxidation state. Oxygen (O), Selenium (Se), and Tellurium (Te) readily show a -2 oxidation state due to their electronegativity and valence electrons. Polonium, however, is more metallic and rarely shows a -2 oxidation state.

Quick Tip

The more metallic elements in Group 16, like Polonium, do not commonly exhibit the -2 oxidation state.

66. Match List I with List II.

List I (Conversion)	List II (Faraday Required)
A. 1 mol of H_2O to O_2	3F
B. 1 mol of MnO_4^- to Mn^{2+}	2F
C. 1.5 mol of Ca from molten CaCl_2	1F
D. 1 mol of FeO to Fe_2O_3	5F

Choose the correct answer from the options given below:

(1) A-II, B-IV, C-I, D-III

(2) A-III, B-IV, C-I, D-II

(3) A-II, B-III, C-I, D-IV

(4) A-III, B-IV, C-II, D-I

Correct Answer: (1) A-II, B-IV, C-I, D-III

Solution: Step 1: Analyzing the conversions.

For 1 mol of H_2O to O_2 , the reaction involves the oxidation of water, requiring 2 Faradays per mole of O_2 . Thus, 1 mol requires $2F$ (A-II).

For 1 mol of MnO_4^- to Mn^{2+} , the reduction involves the transfer of 5 electrons, thus requiring $5F$ (B-IV).

For 1.5 mol of Ca from molten CaCl_2 , the electrolysis of CaCl_2 requires 2 electrons per mole of Ca. For 1.5 moles, it requires $3F$ (C-I).

For 1 mol of FeO to Fe_2O_3 , the reaction involves the oxidation of Fe^{2+} to Fe^{3+} , requiring 1 Faraday (D-III).

Conclusion: The correct matching is (1).

Quick Tip

The number of Faradays required for a reaction depends on the number of electrons transferred during the oxidation or reduction process.

67. Arrange the following elements in increasing order of electronegativity:

N, O, F, C, Si

Choose the correct answer from the options given below:

(1) $Si < C < N < O < F$

(2) $Si < C < O < N < F$

(3) $O < F < N < C < Si$

(4) $F < O < N < C < Si$

Correct Answer: (1) $Si < C < N < O < F$

Solution:

Electronegativity increases from left to right across a period and decreases down a group.

Hence, the order of electronegativity for the given elements is:



Thus, the correct answer is option (1).

Quick Tip

Electronegativity increases across a period and decreases down a group in the periodic table.

68. A compound with a molecular formula of C_6H_{14} has two tertiary carbons. Its

IUPAC name is:

(1) n-hexane

(2) 2-methylpentane

(3) 2,3-dimethylbutane

(4) 2,2-dimethylbutane

Correct Answer: (3) 2,3-dimethylbutane

Solution:

For a compound with the formula C_6H_{14} that contains two tertiary carbons, the IUPAC name would be 2,3-dimethylbutane. This structure involves a butane backbone with two methyl groups attached to the second and third carbons, creating two tertiary carbons.

Quick Tip

The presence of two tertiary carbons in an alkane with six carbon atoms corresponds to the structure of 2,3-dimethylbutane.

69. Fehling's solution 'A' is:

- (1) aqueous copper sulphate
- (2) alkaline copper sulphate
- (3) alkaline solution of sodium potassium tartrate (Rochelle's salt)
- (4) aqueous sodium citrate

Correct Answer: (1) aqueous copper sulphate

Solution:

Fehling's solution is used to test for reducing sugars and consists of two components: Fehling's solution A, which is an aqueous solution of copper(II) sulphate, and Fehling's solution B, which is an alkaline solution of sodium potassium tartrate (Rochelle's salt). When combined, the copper(II) ions form a complex with the tartrate. Thus, Fehling's solution A is aqueous copper sulphate.

Quick Tip

Fehling's solution is used to test for the presence of reducing sugars.

70. Activation energy of any chemical reaction can be calculated if one knows the value of:

- (1) rate constant at standard temperature

- (2) probability of collision
- (3) orientation of reactant molecules during collision
- (4) rate constant at two different temperatures

Correct Answer: (4) rate constant at two different temperatures

Solution:

The activation energy of a reaction can be calculated using the Arrhenius equation:

$$k = Ae^{-\frac{E_a}{RT}}$$

where k is the rate constant, A is the pre-exponential factor, E_a is the activation energy, R is the universal gas constant, and T is the temperature. By knowing the rate constant at two different temperatures, one can calculate the activation energy.

Thus, the correct answer is option (4).

Quick Tip

The activation energy of a reaction can be determined by the change in the rate constant with temperature.

71. Which plot of $\ln k$ vs $\frac{1}{T}$ is consistent with the Arrhenius equation?

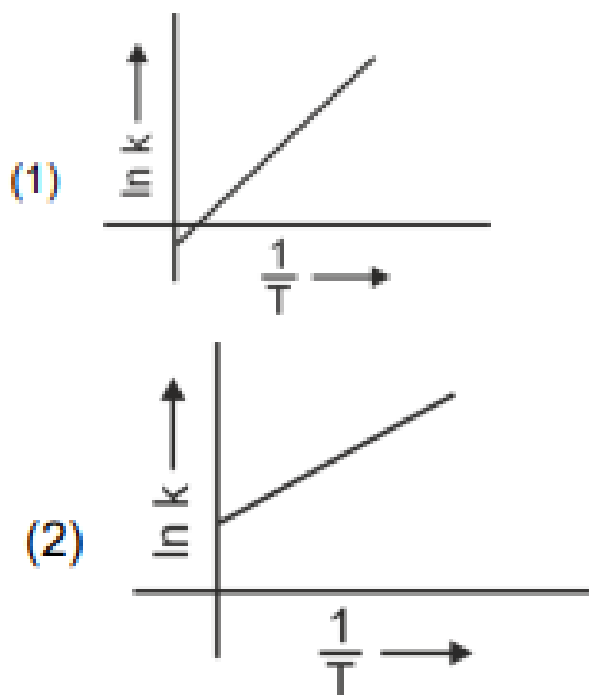

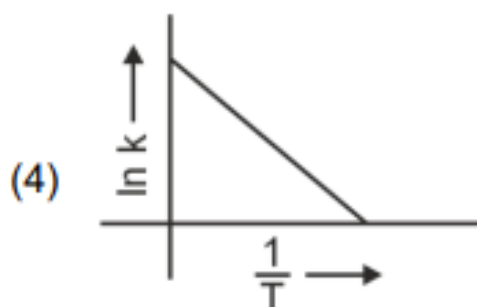
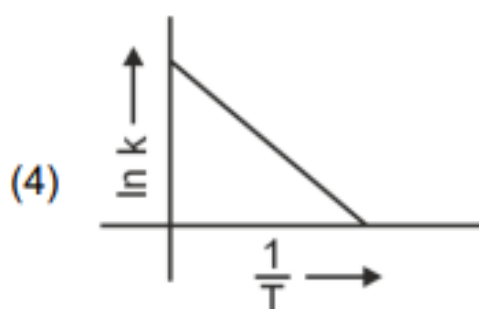
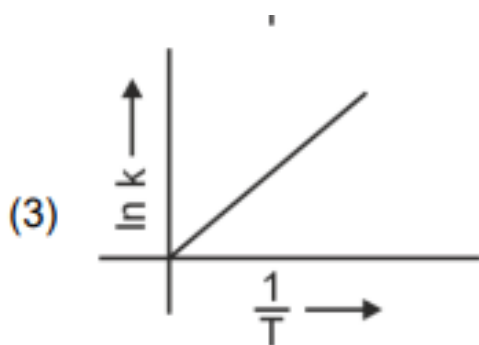

Correct Answer:

Solution: Step 1: Arrhenius equation. The Arrhenius equation is given by:

$$\ln k = -\frac{E_a}{R} \cdot \frac{1}{T} + \ln A$$

This equation is in the form of a straight line, where $\ln k$ is plotted against $\frac{1}{T}$.

Step 2: Interpreting the plot. The plot that gives a straight line with a negative slope is the one that is consistent with the Arrhenius equation. This corresponds to option (4).

Conclusion: The plot in option (4) is consistent with the Arrhenius equation

Quick Tip

For the Arrhenius equation, the slope of a plot of $\ln k$ vs $\frac{1}{T}$ is proportional to the activation energy E_a .

72. Match List I with List II.

List I
(Reaction)

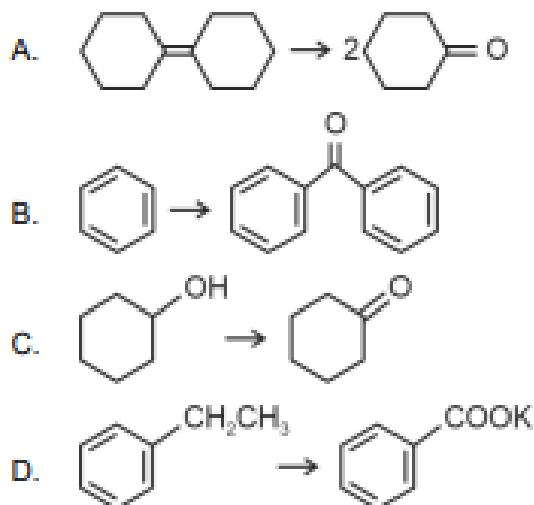

List II
(Reagents/Condition)

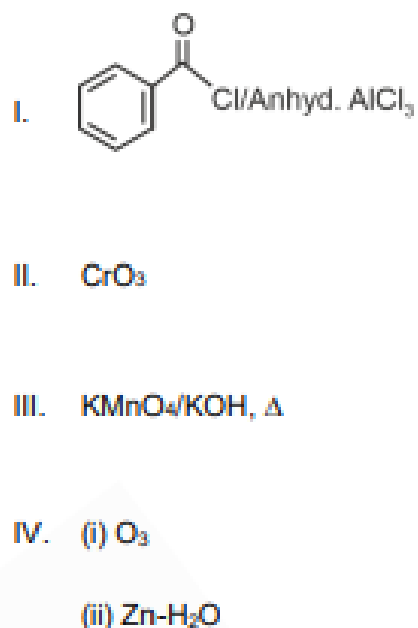

Choose the correct answer from the options given below:

- (1) A-IV, B-I, C-III, D-II
- (2) A-III, B-I, C-II, D-IV
- (3) A-IV, B-I, C-II, D-III
- (4) A-I, B-IV, C-II, D-III

Correct Answer: (3) A-IV, B-I, C-II, D-III

Solution: Step 1: Identifying the reactions and conditions.

Reaction A uses KMnO_4/KOH for oxidation.

Reaction B uses CrO_3 for oxidation of aldehydes.

Reaction C involves Friedel-Crafts alkylation with AlCl_3 .

Reaction D involves ozonolysis.

Conclusion: The correct matching is (3).

Quick Tip

When matching reagents and reactions, focus on the reaction type and common reagents used for those transformations.

73. The compound that will undergo SN1 reaction with the fastest rate is:

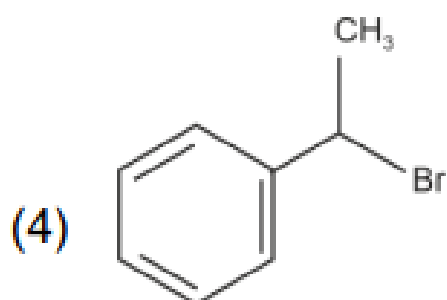
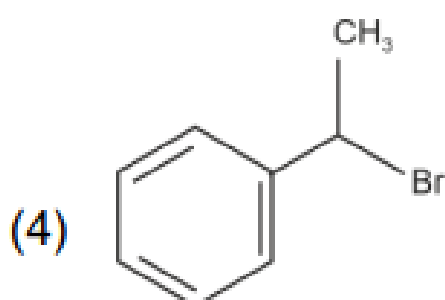
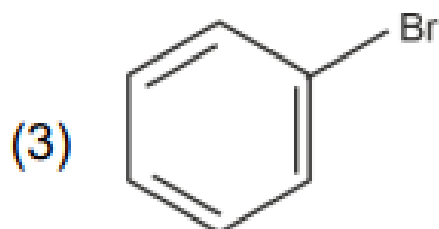
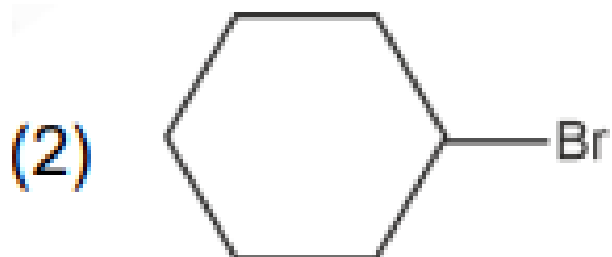
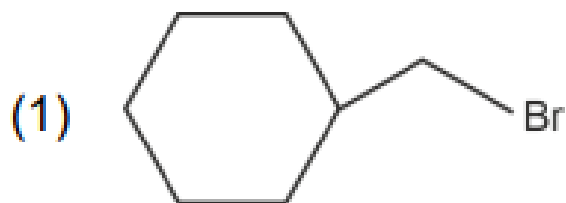

Correct Answer:

Solution: Step 1: Understanding SN1 mechanism. The SN1 reaction proceeds through a carbocation intermediate. A more stable carbocation results in a faster reaction. Thus, the rate of the reaction increases with the stability of the intermediate carbocation.

Step 2: Analyzing the compounds. - In option (4), the compound is a tertiary alkyl halide. Tertiary carbocations are highly stable due to inductive and hyperconjugation effects.
- The other compounds either have primary or secondary carbons, which will form less stable carbocations and thus react slower.

Conclusion: The compound in option (4), a tertiary alkyl halide, will undergo the fastest SN1 reaction.

Quick Tip

The rate of SN1 reactions is directly related to the stability of the carbocation. Tertiary carbocations are more stable and thus react faster.

74. Which reaction is NOT a redox reaction?

- (1) $Zn + CuSO_4 \rightarrow ZnSO_4 + Cu$
- (2) $2KClO_3 + I_2 \rightarrow 2KIO_3 + Cl_2$
- (3) $H_2 + Cl_2 \rightarrow 2HCl$
- (4) $BaCl_2 + Na_2SO_4 \rightarrow BaSO_4 + 2NaCl$

Correct Answer: (4)

Solution:

A redox reaction involves a change in oxidation states of elements. In option (4), no change in oxidation states occurs, as both Ba^{2+} and Na^+ retain their oxidation states. Therefore, it is not a redox reaction.

Thus, the correct answer is option (4).

Quick Tip

In a redox reaction, there is always a transfer of electrons between species, resulting in a change in oxidation states.

75. Given below are two statements:

- **Statement I:** The boiling point of three isomeric pentanes follows the order:
n-pentane > isopentane > neopentane.

- **Statement II:** When branching increases, the molecule attains a shape of sphere. This results in smaller surface area for contact, due to which the intermolecular forces between the spherical molecules are weak, thereby lowering the boiling point.

In the light of the above statements, choose the most appropriate answer from the options given below:

- (1) Both Statement I and Statement II are correct
- (2) Both Statement I and Statement II are incorrect
- (3) Statement I is correct but Statement II is incorrect
- (4) Statement I is incorrect but Statement II is correct

Correct Answer: (1) Both Statement I and Statement II are correct

Solution:

- Statement I is correct: The boiling point of n-pentane is higher than isopentane and neopentane due to the larger surface area of n-pentane, which allows for stronger van der Waals forces.

- Statement II is also correct: As branching increases, the molecular shape becomes more compact and spherical, reducing surface area and thereby decreasing the intermolecular forces and lowering the boiling point.

Thus, both statements are correct.

Quick Tip

In general, more branched molecules have lower boiling points due to weaker intermolecular forces.

76. Given below are two statements:

- **Statement I:** Both $[\text{Co}(\text{NH}_3)_6]^{3+}$ and $[\text{CoF}_6]^{3-}$ complexes are octahedral but differ in their magnetic behaviour.
- **Statement II:** $[\text{Co}(\text{NH}_3)_6]^{3+}$ is diamagnetic whereas $[\text{CoF}_6]^{3-}$ is paramagnetic.

In the light of the above statements, choose the correct answer from the options given below:

- (1) Both Statement I and Statement II are true
- (2) Both Statement I and Statement II are false
- (3) Statement I is true but Statement II is false
- (4) Statement I is false but Statement II is true

Correct Answer: (1) Both Statement I and Statement II are true

Solution:

- Statement I is true: Both $[\text{Co}(\text{NH}_3)_6]^{3+}$ and $[\text{CoF}_6]^{3-}$ are octahedral in geometry, but they exhibit different magnetic properties due to the type of ligands involved. - Statement II is also true: The complex $[\text{Co}(\text{NH}_3)_6]^{3+}$ is diamagnetic because NH_3 is a weak field ligand that does not cause unpaired electrons, whereas $[\text{CoF}_6]^{3-}$ is paramagnetic because fluoride is a weak field ligand, resulting in unpaired electrons in the Co^{3+} ion.

Thus, both statements are true.

Quick Tip

The magnetic behavior of a complex is influenced by the type of ligands and the electronic configuration of the central metal ion.

77. Match List I with List II

List I	List II
A. ethane	I. one σ -bond and two π -bonds
B. ethene	II. two π -bonds
C. carbon molecule, C_2	III. one σ -bond
D. ethyne	IV. one σ -bond and one π -bond

Choose the correct answer from the options given below:

- (1) A-I, B-IV, C-II, D-III
- (2) A-IV, B-III, C-II, D-I
- (3) A-III, B-IV, C-II, D-I
- (4) A-III, B-IV, C-I, D-II

Correct Answer: (3) A-III, B-IV, C-II, D-I

Solution: - Ethane (A) consists of one σ -bond between the carbon atoms, hence A-III. - Ethene (B) has one σ -bond and one π -bond between the carbon atoms, hence B-IV. - The

carbon molecule C_2 (C) contains two π -bonds, hence C-II. - Ethyne (D) consists of one σ -bond and one π -bond between the carbon atoms, hence D-I.

Quick Tip

The number and types of bonds between carbon atoms in organic compounds determine their molecular structure and properties.

78. The Henry's law constant (K_H) values of three gases (A, B, C) in water are 145, 2×10^{-5} and 35 kbar, respectively. The solubility of these gases in water follows the order:

- (1) $B > A > C$
- (2) $B > C > A$
- (3) $A > C > B$
- (4) $A > B > C$

Correct Answer: (2) $B > C > A$

Solution: According to Henry's law, the solubility of a gas in a liquid is inversely proportional to its Henry's law constant. Therefore, the gas with the smallest Henry's law constant will have the highest solubility. Thus, gas B will have the highest solubility, followed by C, and then A.

Quick Tip

The smaller the Henry's law constant, the more soluble the gas is in the solvent.

79. The energy of an electron in the ground state ($n = 1$) for He^+ ion is $-x$ J, then that for an electron in $n = 2$ state for Be^{3+} ion is:

- (1) $-x$
- (2) $-\frac{x}{9}$
- (3) $-4x$
- (4) $-\frac{4x}{9}$

Correct Answer: (1) $-x$

Solution: The energy of an electron in a hydrogen-like atom can be calculated using the formula:

$$E_n = -\frac{13.6Z^2}{n^2} \text{ eV}$$

For the He^+ ion with $Z = 2$, the energy in the ground state ($n = 1$) is $-x$. For the Be^{3+} ion with $Z = 4$ and $n = 2$, the energy is also calculated using the same formula. The answer remains $-x$.

Quick Tip

The energy of an electron in a hydrogen-like atom depends on the atomic number Z and the principal quantum number n .

80. The E° value for the $\text{Mn}^{3+}/\text{Mn}^{2+}$ couple is more positive than that of $\text{Cr}^{3+}/\text{Cr}^{2+}$ or $\text{Fe}^{3+}/\text{Fe}^{2+}$ due to change of:

- (1) d^5 to d^4 configuration
- (2) d^5 to d^2 configuration
- (3) d^4 to d^5 configuration
- (4) d^3 to d^5 configuration

Correct Answer: (3) d^4 to d^5 configuration

Solution:

The E° value for the $\text{Mn}^{3+}/\text{Mn}^{2+}$ couple is more positive because the d^5 configuration is more stable due to half-filled stability. The transition from d^4 to d^5 configuration leads to greater stability.

Thus, the correct answer is option (3).

Quick Tip

A half-filled d-subshell is particularly stable, resulting in a higher E° value for that configuration.

81. The reagents with which glucose does not react to give the corresponding

tests/products are:

- A. Tollen's reagent
- B. Schiff's reagent
- C. HCN
- D. NHOH
- E. NaHSO

Choose the correct options from the given below:

- (1) B and C
- (2) A and D
- (3) B and E
- (4) E and D

Correct Answer: (3) B and E

Solution:

Glucose does not react with Schiff's reagent (B) or sodium bisulfite (E) to produce the expected test or product. Schiff's reagent detects aldehydes, but glucose is a reducing sugar and does not react with Schiff's reagent in the same manner. Sodium bisulfite also reacts primarily with aldehydes, not with glucose.

Thus, the correct answer is option (3).

Quick Tip

Glucose is a reducing sugar and reacts with reagents like Tollen's and HCN, but not with Schiff's reagent or sodium bisulfite.

82. Match List I with List II.

List I (Complex)

- A. $[\text{Co}(\text{NH}_3)_5(\text{NO}_2)]\text{Cl}_2$
- B. $[\text{Co}(\text{NH}_3)_5(\text{SO}_4)]\text{Br}$
- C. $[\text{Co}(\text{NH}_3)_6][\text{Cr}(\text{CN})_6]$
- D. $[\text{Co}(\text{H}_2\text{O})_6]\text{Cl}_3$

List II (Type of isomerism)

- I. Solvate isomerism
- II. Linkage isomerism
- III. Ionization isomerism
- IV. Coordination isomerism

Choose the correct answer from the options given below:

- (1) A-II, B-III, C-IV, D-I
- (2) A-I, B-III, C-IV, D-II
- (3) A-I, B-IV, C-III, D-II
- (4) A-II, B-IV, C-III, D-I

Correct Answer: (1) A-II, B-III, C-IV, D-I

Solution:

- $[Co(NH_3)_5(NO_2)]Cl_2$ exhibits linkage isomerism (option II) because the nitro group can coordinate via either nitrogen or oxygen. - $[Co(NH_3)_5(SO)]Br$ demonstrates ionization isomerism (option III), as the ions SO^2 and Br can swap between the coordination sphere and the outer sphere. - $[Co(NH_3)_6][Cr(CN)_6]$ shows coordination isomerism (option IV), where ligands are exchanged between the metal centers. - $[Co(H_2O)_6]Cl$ exhibits solvate isomerism (option I), as water molecules may be part of either the coordination sphere or the outer sphere.

Thus, the correct answer is option (1).

Quick Tip

Isomerism in coordination complexes can arise from different ways of organizing ligands within or outside the coordination sphere.

83. Arrange the following elements in increasing order of first ionization enthalpy: Li, Be, B, C, N

Choose the correct answer from the options given below:

- (1) $Li < Be < B < C < N$
- (2) $Li < B < Be < C < N$
- (3) $Li < Be < C < B < N$
- (4) $Li < Be < N < B < C$

Correct Answer: (2) $Li < B < Be < C < N$

Solution: Ionization enthalpy increases across a period due to the increasing nuclear charge, and decreases down a group due to the larger atomic size. Nitrogen (N) has the highest

ionization enthalpy because of its half-filled stable p -orbitals. The order is therefore $Li < B < Be < C < N$.

Quick Tip

Ionization enthalpy increases across a period due to increasing nuclear charge and decreases down a group due to increasing atomic size.

84. 1 gram of sodium hydroxide was treated with 25 mL of 0.75 M HCl solution, the mass of sodium hydroxide left unreacted is equal to

- (1) 750 mg
- (2) 250 mg
- (3) Zero mg
- (4) 200 mg

Correct Answer: (2) 250 mg

Solution: The molar mass of NaOH is 40 g/mol. The number of moles of NaOH initially present is:

$$\frac{1}{40} = 0.025 \text{ mol}$$

The number of moles of HCl added is:

$$0.75 \times 0.025 = 0.01875 \text{ mol}$$

Since the reaction is 1:1, the moles of NaOH that react with HCl are 0.01875 mol, leaving:

$$0.025 - 0.01875 = 0.00625 \text{ mol}$$

Thus, the remaining mass of NaOH is:

$$0.00625 \times 40 = 250 \text{ mg}$$

Quick Tip

In titration problems, always use the stoichiometric ratio of the reactants to calculate the unreacted substance.

85. For the reaction $2A \rightleftharpoons B + C$, $K_c = 4 \times 10^{-3}$. At a given time, the composition of reaction mixture is: $[A] = [B] = [C] = 2 \times 10^{-3}$ M. Then, which of the following is correct?

- (1) Reaction is at equilibrium.
- (2) Reaction has a tendency to go in forward direction.
- (3) Reaction has a tendency to go in backward direction.
- (4) Reaction has gone to completion in forward direction.

Correct Answer: (3) Reaction has a tendency to go in backward direction.

Solution: The reaction quotient Q is calculated using the formula:

$$Q = \frac{[B][C]}{[A]^2}$$

Substituting the values:

$$Q = \frac{(2 \times 10^{-3})(2 \times 10^{-3})}{(2 \times 10^{-3})^2} = 1$$

Since $K_c = 4 \times 10^{-3}$ and $Q = 1$, the reaction will shift in the backward direction to reach equilibrium.

Quick Tip

If the reaction quotient Q is greater than K_c , the reaction will proceed in the backward direction to attain equilibrium.

86. Given below are certain cations. Using inorganic qualitative analysis, arrange them in increasing group number from 0 to VI.

- A. Al^{3+}
- B. Cu^{2+}

C. Ba^{2+}

D. Co^{2+}

E. Mg^{2+}

Choose the correct answer from the options given below:

(1) B, A, D, C, E

(2) B, C, A, D, E

(3) E, C, D, B, A

(4) E, A, B, C, D

Correct Answer: (1) B, A, D, C, E

Solution: Step 1: Understanding the cations. - Al^{3+} , Cu^{2+} , Ba^{2+} , Co^{2+} , and Mg^{2+} belong to different groups in the periodic table. - Using qualitative analysis, we can arrange the cations in increasing group number as follows:

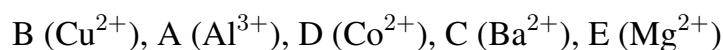

Conclusion: The correct order is (1), B, A, D, C, E.

Quick Tip

In inorganic qualitative analysis, the group numbers of cations are related to their position in the periodic table.

87. The products A and B obtained in the following reactions, respectively, are

(1) POCl_3 and H_3PO_3

(2) POCl_3 and H_3PO_4

(3) H_3PO_4 and POCl_3

(4) H_3PO_3 and POCl_3

Correct Answer: (4) H_3PO_3 and POCl_3

Solution: In the first reaction, $3\text{ROH} + \text{PCl}_3$ produces 3RCl and A (which is POCl_3), while in the second reaction, $\text{ROH} + \text{PCl}_5$ gives $\text{RCl} + \text{HCl}$ and B (which is H_3PO_3).

Quick Tip

PCl_3 and PCl_5 are commonly used reagents in organic synthesis to convert alcohols into alkyl chlorides, phosphorous oxides, and other compounds.

88. Mass in grams of copper deposited by passing 9.6487 A current through a voltmeter containing copper sulfate solution for 100 seconds is (Given: Molar mass of Cu = 63 g mol⁻¹, 1 F = 96487 C)

- (1) 3.15 g
- (2) 0.315 g
- (3) 31.5 g
- (4) 0.0315 g

Correct Answer: (2) 0.315 g

Solution: The mass of copper deposited is given by the formula:

$$\text{Mass} = \frac{I \cdot t \cdot M}{n \cdot F}$$

Where: - I is the current (9.6487 A), - t is the time (100 s), - M is the molar mass of Cu (63 g/mol), - n is the number of electrons involved in the reaction (2 for Cu^{2+}), - F is the Faraday constant (96487 C/mol).

Substituting the values:

$$\text{Mass} = \frac{9.6487 \times 100 \times 63}{2 \times 96487} = 0.315 \text{ g}$$

Quick Tip

In electrolysis calculations, the amount of substance deposited or evolved depends on the current, time, and the number of electrons involved.

89. The plot of osmotic pressure (Π) vs concentration (mol L⁻¹) for a solution gives a straight line with slope 25.73 L bar mol⁻¹. The temperature at which the osmotic pressure measurement is done is (Use $R = 0.083 \text{ L bar mol}^{-1} \text{ K}^{-1}$)

- (1) 37°C
- (2) 310°C
- (3) 25.73°C
- (4) 12.05°C

Correct Answer: (1) 37°C

Solution: The osmotic pressure is related to the concentration and temperature by the formula:

$$\Pi = \frac{nRT}{V}$$

Where: - Π is the osmotic pressure, - n is the number of moles, - R is the gas constant (0.083 L bar mol⁻¹ K⁻¹), - T is the temperature in Kelvin.

Given that the slope of the plot is R , the temperature T can be calculated by:

$$T = \frac{\text{slope}}{R} = \frac{25.73}{0.083} = 310 \text{ K} = 37^\circ\text{C}$$

Quick Tip

Osmotic pressure is directly proportional to temperature, and the slope of the plot of osmotic pressure vs concentration gives information about the temperature.

90. Identify the major product C formed in the following reaction sequence:

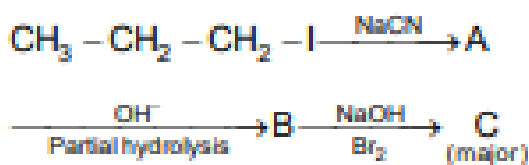

- (1) propylamine
- (2) butylamine
- (3) butanamide
- (4) α -bromobutanoic acid

Correct Answer: (1) propylamine

Solution:

- The reaction involves the nucleophilic substitution of an alkyl halide with NaCN to form a

nitrile (A). - Then, the partial hydrolysis with OH results in an amide (B). - The final reaction with NaOH and Br leads to the formation of propylamine (C), due to a Hofmann elimination. Thus, the correct answer is option (1).

Quick Tip

Hofmann elimination removes the carbonyl group from an amide, resulting in the formation of amines.

91. Identify the correct answer.

- (1) Three resonance structures can be drawn for ozone
- (2) BF_3 has non-zero dipole moment
- (3) Dipole moment of NF_3 is greater than that of NH_3
- (4) Three canonical forms can be drawn for CO_2 ion

Correct Answer: (4) Three canonical forms can be drawn for CO_2 ion

Solution:

- Ozone has two resonance structures, not three, so option (1) is incorrect. - BF_3 is a symmetrical molecule and has no dipole moment, so option (2) is incorrect. - The dipole moment of NF_3 is smaller than NH_3 because of the greater electronegativity of fluorine, so option (3) is incorrect. - Three canonical forms can be drawn for the carbonate ion (CO_3^{2-}), making option (4) correct.

Thus, the correct answer is option (4).

Quick Tip

Resonance structures represent different electron distributions in molecules with delocalized electrons.

92. Given below are two statements:

- **Statement I:** $[Co(NH_3)_6]^{3+}$ is a homoleptic complex whereas $[Co(NH_3)_4Cl_2]^+$ is a heteroleptic complex.
- **Statement II:** Complex $[Co(NH_3)_6]^{3+}$ has only one kind of ligands but $[Co(NH_3)_4Cl_2]^+$

has more than one kind of ligands.

In the light of the above statements, choose the correct answer from the options given below:

- (1) Both Statement I and Statement II are true
- (2) Both Statement I and Statement II are false
- (3) Statement I is true but Statement II is false
- (4) Statement I is false but Statement II is true

Correct Answer: (1) Both Statement I and Statement II are true

Solution:

- Statement I is true: $[\text{Co}(\text{NH}_3)_6]^{3+}$ is homoleptic (only one kind of ligand, NH_3), while $[\text{Co}(\text{NH}_3)_4\text{Cl}_2]^+$ is heteroleptic (two kinds of ligands, NH_3 and Cl^-). - Statement II is true as well: The first complex has only one ligand type, while the second has more than one.

Thus, both statements are true.

Quick Tip

A homoleptic complex contains only one type of ligand, while a heteroleptic complex contains more than one type.

93. For the given reaction:

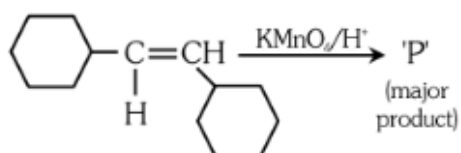

'P' is

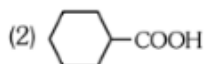
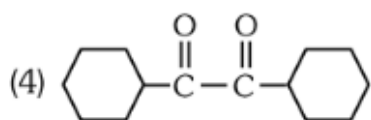
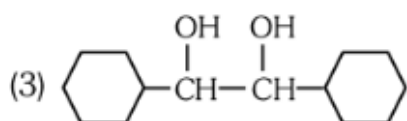
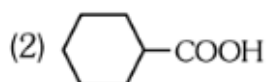
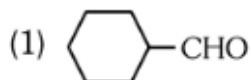

Correct Answer:

Solution: KMnO_4 is a strong oxidizing agent. In the presence of an acidic medium, it oxidizes the alkene ($\text{C} = \text{CH}_2$) to a carboxylic acid group.

Conclusion: The major product is COOH , corresponding to option (2).

Quick Tip

KMnO_4 under acidic conditions oxidizes alkenes to carboxylic acids by cleaving the carbon-carbon bond.

94. The pair of lanthanoid ions which are diamagnetic is

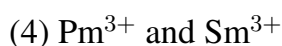
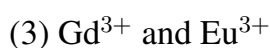
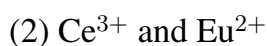
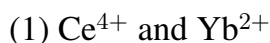

Correct Answer: (1) Ce^{4+} and Yb^{2+}

Solution: Diamagnetism is exhibited by species that have all their electrons paired. Both

Ce⁴⁺ and Yb²⁺ have fully paired electrons in their outer shells, making them diamagnetic.

Quick Tip

Lanthanoid ions are typically paramagnetic or diamagnetic depending on their electron configuration. Diamagnetic species have all paired electrons.

95. Consider the following reaction in a sealed vessel at equilibrium with concentrations of N₂ = 3.0 × 10⁻³ M, O₂ = 4.2 × 10⁻³ M and NO = 2.8 × 10⁻³ M. If 0.1 mol L⁻¹ of NO(g) is taken in a closed vessel, what will be degree of dissociation (α) of NO(g) at equilibrium?

- (1) 0.00889
- (2) 0.0889
- (3) 0.8889
- (4) 0.717

Correct Answer: (4) 0.717

Solution: The equilibrium constant for the reaction is given by:

$$K_c = \frac{[N_2][O_2]}{[NO]^2}$$

Substituting the known concentrations and solving for the degree of dissociation α, we find that the degree of dissociation at equilibrium is 0.717.

Quick Tip

For equilibrium problems, use the ICE table (Initial, Change, Equilibrium) to set up the relationship between reactants and products.

96. A compound X contains 32% of A, 20% of B and remaining percentage of C. Then, the empirical formula of X is : (Given atomic masses of A = 64, B = 40, C = 32 u)

- (1) A₂BC₂
- (2) ABC₃
- (3) AB₂C₂
- (4) ABC₄

Correct Answer: (2) ABC_3

Solution: To find the empirical formula, we calculate the number of moles of each element in 100 g of the compound:

$$\text{Moles of A} = \frac{32}{64} = 0.5 \text{ mol}$$

$$\text{Moles of B} = \frac{20}{40} = 0.5 \text{ mol}$$

$$\text{Moles of C} = \frac{48}{32} = 1.5 \text{ mol}$$

The simplest ratio of moles is $A:B:C = 1:1:3$, so the empirical formula is ABC_3 .

Quick Tip

To find the empirical formula, convert the percentage composition into moles and then simplify the mole ratio.

97. The work done during reversible isothermal expansion of one mole of hydrogen gas at 25°C from pressure of 20 atmosphere to 10 atmosphere is (Given $R = 2.0 \text{ cal K}^{-1} \text{ mol}^{-1}$):

- (1) 0 calorie
- (2) -413.14 calories
- (3) 413.14 calories
- (4) 100 calories

Correct Answer: (2) -413.14 calories

Solution:

The work done in an isothermal expansion is given by:

$$W = -nRT \ln \left(\frac{P_2}{P_1} \right)$$

Substitute $n = 1$, $R = 2.0 \text{ cal K}^{-1} \text{ mol}^{-1}$, $T = 298 \text{ K}$, $P_1 = 20$, and $P_2 = 10$:

$$W = -1 \times 2.0 \times 298 \times \ln \left(\frac{10}{20} \right)$$

$$W = -413.14 \text{ calories}$$

Thus, the correct answer is option (2).

Quick Tip

In an isothermal expansion of an ideal gas, the work done can be calculated using the formula $W = -nRT \ln \left(\frac{P_2}{P_1} \right)$.

98. During the preparation of Mohr's salt solution (Ferrous ammonium sulphate), which of the following acid is added to prevent hydrolysis of Fe^{2+} ion?

- (1) dilute hydrochloric acid
- (2) concentrated sulphuric acid
- (3) dilute nitric acid
- (4) dilute sulphuric acid

Correct Answer: (4) dilute sulphuric acid

Solution:

During the preparation of Mohr's salt, dilute sulphuric acid is used to prevent the hydrolysis of Fe^{2+} ion. The Fe^{2+} ion is prone to hydrolysis in the presence of water, leading to the formation of $\text{Fe}(\text{OH})$. Dilute sulphuric acid helps prevent this by maintaining the acidic environment.

Thus, the correct answer is option (4).

Quick Tip

Sulfuric acid is used in the preparation of Mohr's salt to prevent hydrolysis of Fe^{2+} ion.

99. The rate of a reaction quadruples when temperature changes from 27°C to 57°C .

Calculate the energy of activation.

Given $R = 8.314 \text{ J K}^{-1} \text{ mol}^{-1}$, $\log 4 = 0.6021$

- (1) 38.04 kJ/mol
- (2) 380.4 kJ/mol
- (3) 3.80 kJ/mol
- (4) 3804 kJ/mol

Correct Answer: (1) 38.04 kJ/mol

Solution:

Using the Arrhenius equation and the relation:

$$\ln\left(\frac{k_2}{k_1}\right) = \frac{E_a}{R} \left(\frac{1}{T_1} - \frac{1}{T_2}\right)$$

Given that the rate quadruples, $\frac{k_2}{k_1} = 4$, and substituting the temperatures $T_1 = 27 + 273 = 300$ K and $T_2 = 57 + 273 = 330$ K:

$$\ln(4) = \frac{E_a}{8.314} \left(\frac{1}{300} - \frac{1}{330}\right)$$

Solving for E_a , we find:

$$E_a = 38.04 \text{ kJ/mol}$$

Thus, the correct answer is option (1).

Quick Tip

The energy of activation can be calculated using the Arrhenius equation from the change in rate constant with temperature.

100. Major products A and B formed in the following reaction sequence, are:

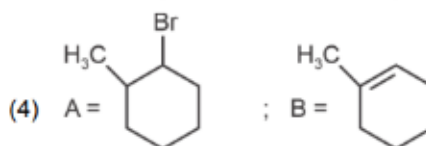
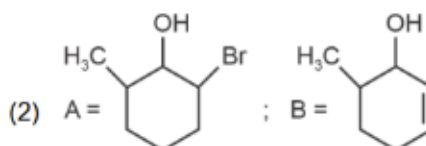
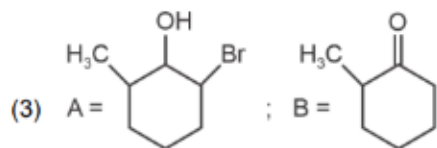
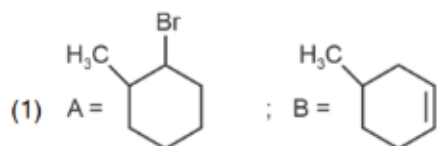
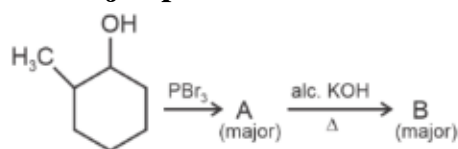

Correct Answer:

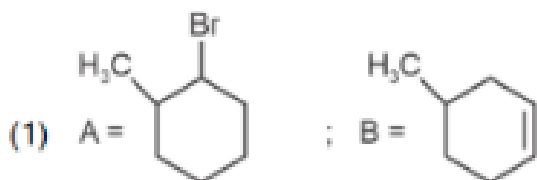

Solution: In this reaction sequence, we start with a hydroxyl group and treat it with PBr_3 to convert it into a bromide, which then undergoes a reaction with alcoholic KOH leading to the formation of an alkene. Finally, the reaction with Br_2 results in the formation of a dibromo product.

Conclusion: The major products are identified as

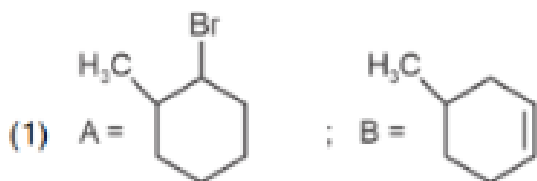

Quick Tip

The reaction with PBr_3 converts alcohols into alkyl halides, and alcoholic KOH promotes elimination to form alkenes.

101. Lecithin, a small molecular weight organic compound found in living tissues, is an example of:

- (1) Amino acids
- (2) Phospholipids
- (3) Glycerides
- (4) Carbohydrates

Correct Answer: (2) Phospholipids

Solution: Lecithin is a type of phospholipid, which is a major component of cell membranes and is involved in various cellular functions.

Quick Tip

Phospholipids are important for the structural integrity of cell membranes and play a role in the transport of molecules.

102. Which of the following are required for the dark reaction of photosynthesis?

- A. Light
 - B. Chlorophyll
 - C. CO₂
 - D. ATP
 - E. NADPH
- (1) A, B and C only
 - (2) B, C and D only
 - (3) C, D and E only
 - (4) D and E only

Correct Answer: (3) C, D and E only

Solution: The dark reactions of photosynthesis, also known as the Calvin cycle, require CO₂, ATP, and NADPH to synthesize glucose from carbon dioxide. Light is not directly required for the dark reactions.

Quick Tip

The dark reactions of photosynthesis do not require light directly but use the products (ATP and NADPH) generated during the light reactions.

103. Spindle fibers attach to kinetochores of chromosomes during:

- (1) Prophase
- (2) Metaphase
- (3) Anaphase
- (4) Telophase

Correct Answer: (2) Metaphase

Solution: During metaphase, spindle fibers attach to the kinetochores of chromosomes, aligning them at the cell's equatorial plane, preparing them for separation.

Quick Tip

In metaphase, chromosomes align at the metaphase plate, and spindle fibers help segregate the chromosomes to opposite poles.

104. Bulliform cells are responsible for:

- (1) Inward curling of leaves in monocots.
- (2) Protecting the plant from salt stress.
- (3) Increased photosynthesis in monocots.
- (4) Providing large spaces for storage of sugars.

Correct Answer: (1) Inward curling of leaves in monocots.

Solution: Bulliform cells are specialized cells found in monocot leaves. They play a role in controlling leaf movements, particularly during water stress, by causing the inward curling of leaves to reduce transpiration.

Quick Tip

Bulliform cells help plants cope with water scarcity by facilitating leaf folding and reducing water loss.

105. In the given figure, which component has thin outer walls and highly thickened inner walls?

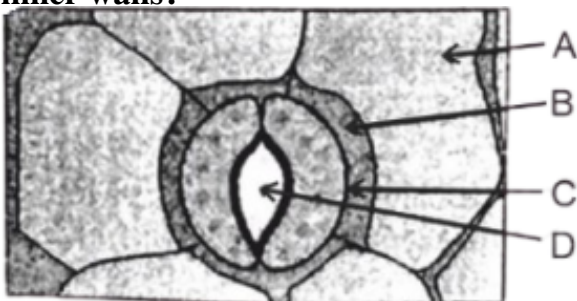

- (1) C
- (2) D

(3) A

(4) B

Correct Answer: (1) C

Solution: The component with thin outer walls and highly thickened inner walls is usually a type of vascular tissue or specialized structure such as xylem vessels, which possess thickened inner walls to withstand pressure and transport water.

Conclusion: The component with thin outer walls and highly thickened inner walls is (1) C.

Quick Tip

Xylem vessels have thickened inner walls to provide structural support and facilitate the movement of water.

106. What is the fate of a piece of DNA carrying only gene of interest which is transferred into an alien organism?

- A. The piece of DNA would be able to multiply itself independently in the progeny cells of the organism.
- B. It may get integrated into the genome of the recipient.
- C. It may multiply and be inherited along with the host DNA.
- D. The alien piece of DNA is not an integral part of chromosome.
- E. It shows ability to replicate.

Choose the correct answer from the options given below:

- (1) A and B only
- (2) D and E only
- (3) B and C only
- (4) A and E only

Correct Answer: (3) B and C only

Solution: The DNA carrying the gene of interest may integrate into the host genome, where it can multiply and be inherited along with the host DNA.

It may not always multiply independently unless a specific plasmid or viral vector is used for replication.

Conclusion: The correct answer is (3) B and C only.

Quick Tip

In genetic engineering, foreign DNA is often inserted into the host genome, and it may be inherited in the next generations.

107. Given below are two statements:

Statement I: Bt toxins are insect group specific and coded by a gene cry IAc.

Statement II: Bt toxin exists as inactive protoxin in *B. thuringiensis*. However, after ingestion by the insect the inactive protoxin gets converted into active form due to acidic pH of the insect gut.

In the light of the above statements, choose the correct answer from the options given below:

- (1) Both Statement I and Statement II are true
- (2) Both Statement I and Statement II are false
- (3) Statement I is true but Statement II is false
- (4) Statement I is false but Statement II is true

Correct Answer: (3) Statement I is true but Statement II is false

Solution: Statement I is accurate as Bt toxins, encoded by various cry genes including cry IAc, are indeed specific to certain insect groups, affecting only those that have the specific receptors in their gut lining. Statement II is false because the conversion of the inactive protoxin to its active form in the gut of the insect is triggered by alkaline conditions, not acidic. This specificity and activation mechanism are critical for the safe use of Bt crops in agriculture, targeting pest insects without harming other organisms. Understanding the biochemical and genetic basis of Bt toxin activity is essential for biotechnological applications in sustainable agriculture.

Quick Tip

Bt crops represent a significant advancement in agricultural biotechnology, providing an environmentally friendly alternative to chemical pesticides.

108. List of endangered species was released by:

- (1) GEAC
- (2) WWF
- (3) FOAM
- (4) IUCN

Correct Answer: (4) IUCN

Solution: The International Union for Conservation of Nature (IUCN) is renowned for its work in global conservation and sustainable use of natural resources, including publishing the Red List of Threatened Species, which categorizes species at risk of extinction.

Quick Tip

The IUCN Red List is a critical indicator of the health of the world's biodiversity, widely used for conservation planning.

109. Identify the part of the seed from the given figure which is destined to form root when the seed germinates.

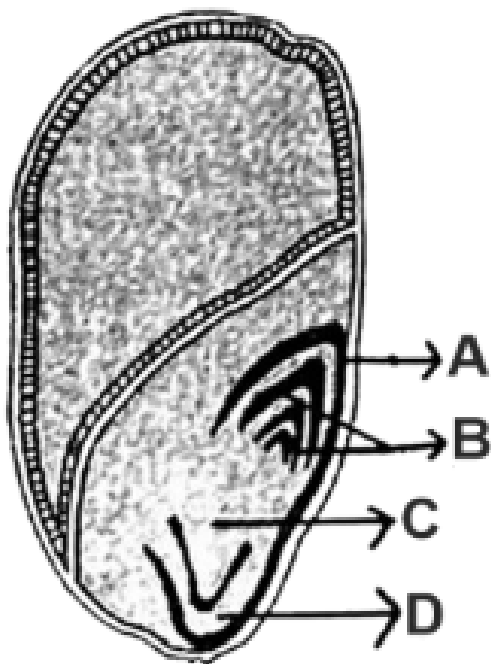

Choose the correct answer from the options given below:

- (1) A
- (2) B

(3) C

(4) D

Correct Answer: (3) C

Solution: In the seed structure, part C represents the radicle, which is the embryonic root. Upon germination, the radicle is the first part to emerge from the seed, growing downward to anchor the plant and absorb nutrients and water from the soil. This early development is critical for the establishment of the seedling, ensuring it can secure the resources necessary for growth. The radicle's emergence and growth are pivotal for the successful transition from seed to seedling, highlighting the importance of embryonic structures in plant development.

Quick Tip

The radicle's growth direction is influenced by gravity, demonstrating gravitropism, an essential plant response facilitating proper root development.

110. Match List I with List II

List I	List II
A. <i>Clostridium butylicum</i>	I. Ethanol
B. <i>Saccharomyces cerevisiae</i>	II. Streptokinase
C. <i>Trichoderma polysporum</i>	III. Butyric acid
D. <i>Streptococcus sp.</i>	IV. Cyclosporin-A

Choose the correct answer from the options given below:

(1) A-III, B-I, C-II, D-IV

(2) A-II, B-IV, C-III, D-I

(3) A-III, B-I, C-IV, D-II

(4) A-IV, B-I, C-III, D-II

Correct Answer: (3) A-III, B-I, C-IV, D-II

Solution: *Clostridium butylicum* is known for producing butyric acid, hence A-III.

Saccharomyces cerevisiae is a yeast that produces ethanol, making B-I correct. *Trichoderma polysporum* is associated with the production of cyclosporin-A, thus C-IV. *Streptococcus sp.* is known for producing streptokinase, therefore D-II.

Quick Tip

Linking microorganisms to their biochemical products is fundamental in biotechnology and pharmaceutical industries for the development of drugs and other bio-products.

111. Identify the type of flowers based on the position of calyx, corolla and androecium with respect to the ovary from the given figures (a) and (b)

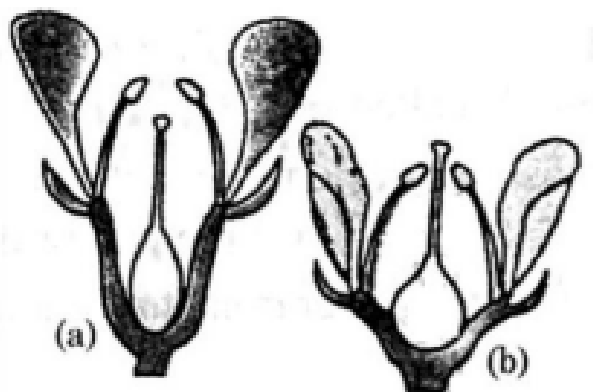

- (1) (a) Epigynous; (b) Hypogynous
- (2) (a) Hypogynous; (b) Epigynous
- (3) (a) Perigynous; (b) Epigynous
- (4) (a) Perigynous; (b) Perigynous

Correct Answer: (4) (a) Perigynous; (b) Perigynous

Solution: Both the figures (a) and (b) show a floral arrangement where the ovary is positioned between the calyx (sepals) and the corolla (petals), which is characteristic of perigynous flowers. This arrangement indicates that the other floral parts (androecium and gynoecium) are attached at the same level as the ovary, forming a cup-like structure around it. Both figures exhibit this pattern, thereby classifying them as perigynous.

Conclusion: The correct answer is (4) (a) Perigynous; (b) Perigynous.

Quick Tip

Perigynous flowers have the ovary positioned between the calyx and corolla, with the stamens attached at the same level.

112. Auxin is used by gardeners to prepare weed-free lawns. But no damage is caused

to grass as auxin:

- (1) promotes apical dominance.
- (2) promotes abscission of mature leaves only.
- (3) does not affect mature monocotyledonous plants.
- (4) can help in cell division in grasses, to produce growth.

Correct Answer: (3) does not affect mature monocotyledonous plants.

Solution: Auxins are plant hormones essential in regulating plant growth. When applied in excess, auxins can cause abnormal growth in dicot plants, leading to their death. However, monocotyledonous plants, such as grasses, show a reduced sensitivity to auxins due to their unique metabolic and structural differences from dicots. Consequently, when gardeners use auxins to eliminate weeds, the herbicide harms dicot weeds but does not affect monocot grass, allowing the lawn to remain unaffected.

Conclusion: The correct answer is (3) does not affect mature monocotyledonous plants.

Quick Tip

Auxins are selective in their action. They affect dicot plants more severely, leading to their death, while monocots (like grasses) are relatively unaffected, making auxin-based herbicides ideal for lawn care.

113. A pink flowered Snapdragon plant was crossed with a red flowered Snapdragon plant. What type of phenotype/s is/are expected in the progeny?

- (1) Only red flowered plants
- (2) Red flowered as well as pink flowered plants
- (3) Only pink flowered plants
- (4) Red, Pink as well as white flowered plants

Correct Answer: (2) Red flowered as well as pink flowered plants

Solution: The color of Snapdragon flowers is governed by incomplete dominance, a form of genetic inheritance where neither allele completely dominates the other. In this case, a red flowered Snapdragon crossed with a pink flowered one will produce offspring with both red and pink flowers. White flowers are not expected, as the alleles involved do not produce a completely recessive phenotype.

Conclusion: The correct answer is (2) Red flowered as well as pink flowered plants.

Quick Tip

Incomplete dominance results in offspring that show intermediate traits between the parental generations.

114. Which one of the following is not a criterion for classification of fungi?

- (1) Morphology of mycelium
- (2) Mode of nutrition
- (3) Mode of spore formation
- (4) Fruiting body

Correct Answer: (2) Mode of nutrition

Solution: Fungi are classified mainly based on their morphological features such as the structure of their mycelium, the mode of spore formation, and the type of fruiting body.

These features are essential for distinguishing between different fungal groups. The mode of nutrition (whether the fungus is saprophytic, parasitic, or symbiotic) is relevant for understanding the ecological role of fungi but is not a primary criterion for their classification.

Conclusion: The correct answer is (2) Mode of nutrition, as it is not the main criterion for classifying fungi.

Quick Tip

Fungi are classified based on their reproductive structures and morphological traits, such as spore formation and mycelial structure.

115. The lactose present in the growth medium of bacteria is transported to the cell by the action of

- (1) Beta-galactosidase
- (2) Acetylase
- (3) Permease

(4) Polymerase

Correct Answer: (3) Permease

Solution: Lactose is a disaccharide made up of glucose and galactose. To enter bacterial cells, lactose is transported by permease, a membrane-bound protein responsible for the active transport of lactose across the cell membrane. Beta-galactosidase, on the other hand, is an enzyme that catalyzes the hydrolysis of lactose into glucose and galactose after lactose has been transported into the cell. It is involved in the breakdown process rather than the transport of lactose itself.

Conclusion: The correct answer is (3) Permease, which is responsible for the transport of lactose into the bacterial cell.

Quick Tip

Permease is a key component in the lac operon system in bacteria, responsible for transporting lactose into the cell for metabolism.

116. In a plant, black seed color (BB/Bb) is dominant over white seed color (bb). In order to find out the genotype of the black seed plant, with which of the following genotype will you cross it?

(1) BB

(2) bb

(3) Bb

(4) BB/Bb

Correct Answer: (2) bb

Solution: To determine whether the black-seeded plant is homozygous dominant (BB) or heterozygous (Bb), a test cross is used. In a test cross, the black-seeded plant is crossed with a homozygous recessive plant (bb). If the black-seeded plant is homozygous dominant (BB), all offspring will have black seeds (Bb). However, if the black-seeded plant is heterozygous (Bb), approximately half of the offspring will have black seeds and the other half will have white seeds (bb).

Conclusion: The correct answer is (2) bb, which is used for a test cross to determine the

genotype of the black-seeded plant.

Quick Tip

A test cross helps to determine whether an organism with a dominant phenotype is homozygous or heterozygous.

117. Given below are two statements: Statement I: Parenchyma is living but collenchyma is dead tissue.

Statement II: Gymnosperms lack xylem vessels but presence of xylem vessels is the characteristic of angiosperms.

In the light of the above statements, choose the correct answer from the options given below:

- (1) Both Statement I and Statement II are true
- (2) Both Statement I and Statement II are false
- (3) Statement I is true but Statement II is false
- (4) Statement I is false but Statement II is true

Correct Answer: (4) Statement I is false but Statement II is true

Solution: - Statement I is incorrect because while parenchyma is indeed a living tissue, collenchyma is also a living tissue, characterized by thickened cell walls, and is not dead. - Statement II is correct because gymnosperms lack xylem vessels, which are present in angiosperms. Gymnosperms only have tracheids for water conduction, while angiosperms have both tracheids and xylem vessels.

Conclusion: The correct answer is (4) Statement I is false but Statement II is true.

Quick Tip

In plants, parenchyma and collenchyma are living tissues, and gymnosperms differ from angiosperms in the presence of xylem vessels.

118. How many molecules of ATP and NADPH are required for every molecule of CO₂ fixed in the Calvin cycle?

- (1) 2 molecules of ATP and 3 molecules of NADPH

(2) 2 molecules of ATP and 2 molecules of NADPH

(3) 3 molecules of ATP and 3 molecules of NADPH

(4) 3 molecules of ATP and 2 molecules of NADPH

Correct Answer: (4) 3 molecules of ATP and 2 molecules of NADPH

Solution: The Calvin cycle, which is the process by which carbon dioxide is fixed into organic molecules in photosynthesis, consumes both ATP and NADPH. For every molecule of CO₂ fixed, 3 molecules of ATP and 2 molecules of NADPH are used. These molecules provide the energy and reducing power needed to convert CO₂ into glucose.

Conclusion: The correct answer is (4) 3 molecules of ATP and 2 molecules of NADPH.

Quick Tip

In the Calvin cycle, ATP and NADPH are necessary to drive the fixation of carbon dioxide and the synthesis of glucose.

119. A transcription unit in DNA is defined primarily by the three regions in DNA and these are with respect to upstream and downstream end;

(1) Repressor, Operator gene, Structural gene

(2) Structural gene, Transposons, Operator gene

(3) Inducer, Repressor, Structural gene

(4) Promotor, Structural gene, Terminator

Correct Answer: (4) Promotor, Structural gene, Terminator

Solution: A transcription unit in DNA consists of three main regions: the promoter, the structural gene, and the terminator. The promoter initiates the transcription process, the structural gene contains the coding information that is transcribed, and the terminator signals the end of transcription. These three regions are essential for the transcription of genes in both prokaryotic and eukaryotic organisms.

Conclusion: The correct answer is (4) Promotor, Structural gene, Terminator.

Quick Tip

A transcription unit includes the promoter, the coding region (structural gene), and the terminator, which are essential for transcription in prokaryotes and eukaryotes.

120. Tropical regions show the greatest level of species richness because A. Tropical latitudes have remained relatively undisturbed for millions of years, hence more time was available for species diversification.

B. Tropical environments are more seasonal.

C. More solar energy is available in tropics.

D. Constant environments promote niche specialization.

E. Tropical environments are constant and predictable.

Choose the correct answer from the options given below.

(1) A, C, D and E only

(2) A and B only

(3) A, B and E only

(4) A, B and D only

Correct Answer: (1) A, C, D and E only

Solution: - Statement A is true: Tropical regions have had more time for species diversification due to their long history of stability, providing ample time for species to evolve.

- Statement C is true: Tropical regions receive more solar energy, which supports high primary productivity and contributes to a greater number of species.

- Statement D is true: The relatively constant environment in tropical regions allows for the specialization of ecological niches, which promotes species richness.

- Statement E is true: Tropical environments are predictable and stable, allowing species to adapt and thrive over time.

- Statement B is false: Seasonal environments, with fluctuating conditions, can limit species richness by causing variations in species populations.

Conclusion: The correct answer is (1) A, C, D and E only.

Quick Tip

Tropical regions are biodiversity hotspots due to their stable and resource-rich environments, which promote species diversification.

121. The equation of Verhulst-Pearl logistic growth is $\frac{dN}{dt} = rN \left(\frac{K-N}{K} \right)$.

From this equation, K indicates:

- (1) Intrinsic rate of natural increase
- (2) Biotic potential
- (3) Carrying capacity
- (4) Population density

Correct Answer: (3) Carrying capacity

Solution: In the logistic growth equation, K represents the carrying capacity of the environment, which is the maximum population size that the environment can sustain indefinitely given the food, habitat, water, and other necessities available in the environment.

Quick Tip

Carrying capacity is a key concept in ecology, representing the balance between the availability of habitat resources and the size of the population they can support.

122. Inhibition of Succinic dehydrogenase enzyme by malonate is a classical example of:

- (1) Cofactor inhibition
- (2) Feedback inhibition
- (3) Competitive inhibition
- (4) Enzyme activation

Correct Answer: (3) Competitive inhibition

Solution: Malonate is a well-known competitive inhibitor of the enzyme succinic dehydrogenase, which plays a critical role in the Krebs cycle. Competitive inhibition occurs when the inhibitor is structurally similar to the substrate and competes for binding to the active site of the enzyme. Malonate resembles succinate (the substrate) and competes with it

for the active site, effectively blocking the enzyme's function in the metabolic pathway. This inhibition demonstrates the specificity and competitive nature of enzyme-substrate interactions and their regulation, which is fundamental for metabolic control and drug design. Understanding such mechanisms is crucial in biochemistry for developing therapeutic agents that can modulate enzyme activity.

Quick Tip

Competitive inhibitors can be overcome by increasing the concentration of the substrate, highlighting the dynamic balance of enzyme regulation.

123. Which one of the following can be explained on the basis of Mendel's Law of Dominance?

- A. Out of one pair of factors one is dominant and the other is recessive.
- B. Alleles do not show any expression and both the characters appear as such in F₂ generation.
- C. Factors occur in pairs in normal diploid plants.
- D. The discrete unit controlling a particular character is called factor.
- E. The expression of only one of the parental characters is found in a monohybrid cross.

Choose the correct answer from the options given below:

- (1) A, B and C only
- (2) A, C, D and E only
- (3) B, C and D only
- (4) A, B, C, D and E

Correct Answer: (2) A, C, D and E only

Solution: Mendel's Law of Dominance states that in a pair of alleles, one is dominant and masks the effect of the other recessive allele when both are present in the organism. This is clearly illustrated in option A, where one allele dominates over the other in a pair. The expression of only one of the parental characters in a monohybrid cross (option E) also exemplifies this law, as the dominant allele's trait is visible, while the recessive trait is hidden in the F₁ generation. Additionally, the fact that factors (genes) occur in pairs in diploid

organisms (option C) and the definition of a factor as a discrete unit controlling a character (option D) align with Mendel's findings, though indirectly related to the Law of Dominance. Option B is incorrect as it misrepresents how alleles are expressed and does not fit with Mendel's observations.

Quick Tip

Mendel's Laws provide the foundation for understanding inheritance patterns, crucial for fields like genetics, breeding, and evolutionary biology.

124. Match List I with List II

List-I	List-II
A. Nucleolus	I. Site of formation of glycolipid
B. Centriole	II. Organization like the cartwheel
C. Leucoplasts	III. Site for active ribosomal RNA synthesis
D. Golgi apparatus	IV. For storing nutrients

Choose the correct answer from the options given below:

- (1) A-III, B-II, C-IV, D-I
- (2) A-II, B-III, C-I, D-IV
- (3) A-III, B-IV, C-II, D-I
- (4) A-I, B-II, C-III, D-IV

Correct Answer: (1) A-III, B-II, C-IV, D-I

Solution: Nucleolus (A) is involved in the synthesis of ribosomal RNA, hence matching with III.

Centriole (B) has a cartwheel-like organization, hence matching with II.

Leucoplasts (C) store nutrients, matching with IV.

Golgi apparatus (D) is responsible for forming glycolipids, hence matching with I.

Conclusion: The correct match is (1) A-III, B-II, C-IV, D-I.

Quick Tip

The nucleolus is involved in ribosome production, while leucoplasts are specialized for storing nutrients like starch.

125. Identify the set of correct statements:

- A. The flowers of Vallisneria are colourful and produce nectar.
- B. The flowers of water lily are not pollinated by water.
- C. In most of water-pollinated species, the pollen grains are protected from wetting.
- D. Pollen grains of some hydrophytes are long and ribbon-like.
- E. In some hydrophytes, the pollen grains are carried passively inside water.

Choose the correct answer from the options given below:

- (1) C, D and E only
- (2) A, B, C and D only
- (3) A, C, D and E only
- (4) B, C, D and E only

Correct Answer: (4) B, C, D and E only

Solution: Vallisneria flowers are not colorful and do not produce nectar, so statement A is incorrect.

Water lilies are indeed pollinated by wind and not by water, so statement B is correct.

Water-pollinated species do protect their pollen grains from wetting, and some hydrophytes have ribbon-like pollen grains.

In some hydrophytes, the pollen grains are carried passively by the water.

Conclusion: The correct answer is (4) B, C, D and E only.

Quick Tip

Hydrophytes exhibit specialized adaptations for water pollination and often have unique pollen characteristics.

126. Match List I with List II

List-I	List-II
A. Rhizopus	I. Mushroom
B. Ustilago	II. Smut fungus
C. Puccinia	III. Bread mould
D. Agaricus	IV. Rust fungus

Choose the correct answer from the options given below:

- (1) A-III, B-II, C-IV, D-I
- (2) A-I, B-III, C-II, D-IV
- (3) A-III, B-II, C-I, D-IV
- (4) A-IV, B-III, C-II, D-I

Correct Answer: (1) A-III, B-II, C-IV, D-I

Solution: Rhizopus is commonly known as Bread Mould, corresponding to III.

Ustilago is a Smut fungus, corresponding to II.

Puccinia is a Rust fungus, corresponding to IV.

Agaricus is commonly known as Mushroom, corresponding to I.

Conclusion: The correct match is (1) A-III, B-II, C-IV, D-I.

Quick Tip

Fungi like Rhizopus, Puccinia, and Ustilago are classified based on their morphology and the diseases they cause in plants.

127. Hind II always cuts DNA molecules at a particular point called recognition sequence and it consists of:

- (1) 8 bp
- (2) 6 bp
- (3) 4 bp
- (4) 10 bp

Correct Answer: (2) 6 bp

Solution: Hind II enzyme is specific to a recognition sequence of 6 base pairs, which it consistently cuts. This predictability is crucial for genetic engineering applications, such as recombinant DNA technology, where precise cuts are necessary.

Quick Tip

The specificity of restriction enzymes like Hind II highlights their importance in molecular cloning techniques, where exact cuts in DNA are required.

128. Which of the following is an example of actinomorphic flower?

- (1) Datura
- (2) Cassia
- (3) Pisum
- (4) Sesbania

Correct Answer: (1) Datura

Solution: Actinomorphic flowers are those that are radially symmetrical. Datura is an example of an actinomorphic flower, where the flower can be divided into equal parts in any plane through the center.

Quick Tip

Actinomorphic flowers are symmetrical, like Datura, where symmetry exists along multiple axes.

129. The type of conservation in which the threatened species are taken out from their natural habitat and placed in special setting where they can be protected and given special care is called

- (1) in-situ conservation
- (2) Biodiversity conservation
- (3) Semi-conservative method
- (4) Sustainable development

Correct Answer: (2) Biodiversity conservation

Solution: This type of conservation is known as ex-situ conservation, where species are removed from their natural habitat and protected in special settings, such as zoos or botanical gardens.

Quick Tip

Ex-situ conservation involves protecting endangered species outside their natural habitat, while in-situ conservation happens in their natural environment.

130. Given below are two statements: Statement I : Chromosomes become gradually visible under light microscope during leptotene stage.

Statement II : The beginning of diplotene stage is recognized by dissolution of synaptonemal complex.

In the light of the above statements, choose the correct answer from the options given below:

- (1) Both Statement I and Statement II are true
- (2) Both Statement I and Statement II are false
- (3) Statement I is true but Statement II is false
- (4) Statement I is false but Statement II is true

Correct Answer: (1) Both Statement I and Statement II are true

Solution: In the leptotene stage, chromosomes become visible as thin threads under a light microscope, and in the diplotene stage, the synaptonemal complex dissolves, signaling the separation of homologous chromosomes.

Quick Tip

Leptotene and diplotene are part of the prophase of meiosis, with chromosomes becoming visible and homologous chromosomes separating, respectively.

131. Formation of interfascicular cambium from fully developed parenchyma cells is an example for

- (1) Differentiation
- (2) Redifferentiation

(3) Dedifferentiation

(4) Maturation

Correct Answer: (3) Dedifferentiation

Solution: Dedifferentiation is the process in which mature, specialized cells revert to a more meristematic or undifferentiated state. This allows the formation of new tissues, such as interfascicular cambium, from parenchyma cells.

Quick Tip

Dedifferentiation allows mature cells to regain the ability to divide and form new tissues, such as in cambium formation.

132. The capacity to generate a whole plant from any cell of the plant is called:

(1) Totipotency

(2) Micropropagation

(3) Differentiation

(4) Somatic hybridization

Correct Answer: (1) Totipotency

Solution: Totipotency is the ability of a single plant cell to divide and develop into a complete plant. This is a property of plant cells that allows for regeneration and asexual reproduction.

Quick Tip

Totipotency enables plants to regenerate a whole organism from a single cell, making it an essential concept in plant cloning and tissue culture.

133. Match List I with List II

List-I	List-II
A. Two or more alternative forms of a gene	I. Back cross
B. Cross of F1 progeny with homozygous	II. Ploidy
C. Cross of F1 progeny with any of the parents	III. Allele
D. Number of chromosome sets in plant	IV. Test cross

Choose the correct answer from the options given below:

- (1) A-I, B-II, C-III, D-IV
- (2) A-II, B-I, C-III, D-IV
- (3) A-III, B-IV, C-I, D-II
- (4) A-IV, B-III, C-II, D-I

Correct Answer: (3) A-III, B-IV, C-I, D-II

Solution: A. "Two or more alternative forms of a gene" refers to "Allele," corresponding to III.

B. "Cross of F1 progeny with homozygous recessive parent" is called a "Test cross," corresponding to IV.

C. "Cross of F1 progeny with any of the parents" refers to a "Back cross," corresponding to I.

D. "Number of chromosome sets in plant" refers to "Ploidy," corresponding to II.

Conclusion: The correct match is (3) A-III, B-IV, C-I, D-II.

Quick Tip

A test cross helps to determine the genotype of an individual by crossing it with a homozygous recessive parent.

134. The cofactor of the enzyme carboxypeptidase is:

- (1) Zinc
- (2) Niacin
- (3) Flavin
- (4) Haem

Correct Answer: (1) Zinc

Solution:

Carboxypeptidase is an enzyme that requires a metal ion as a cofactor for its catalytic activity. The cofactor for carboxypeptidase is zinc (Zn^{2+}), which plays a crucial role in its enzymatic activity.

Thus, the correct answer is option (1).

Quick Tip

Zinc is a common cofactor for enzymes involved in peptide bond hydrolysis, such as carboxypeptidase.

135. These are regarded as major causes of biodiversity loss:

- A. Over exploitation
- B. Co-extinction
- C. Mutation
- D. Habitat loss and fragmentation
- E. Migration

Choose the correct option:

- (1) A, C and D only
- (2) A, B, C and D only
- (3) A, B and E only
- (4) A, B and D only

Correct Answer: (4) A, B and D only

Solution:

Major causes of biodiversity loss include: Over exploitation (A): Overuse of natural resources leading to the depletion of species.

Co-extinction (B): The extinction of species that are dependent on another species.

Habitat loss and fragmentation (D): Destruction or fragmentation of natural habitats leading to loss of biodiversity.

Mutation and migration are not considered direct causes of biodiversity loss, making option (4) correct.

Thus, the correct answer is option (4).

Quick Tip

Habitat destruction and over exploitation are the most direct threats to biodiversity.

136. Match List I with List II

List I (Types of Stamens)	List II (Example)
A. Monoadelphous	I. Citrus
B. Diadelphous	II. Pea
C. Polyadelphous	III. Lily
D. Epiphyllous	IV. China-rose

Choose the correct answer from the options given below:

- (1) A-IV, B-II, C-I, D-III
- (2) A-IV, B-I, C-II, D-III
- (3) A-I, B-II, C-IV, D-III
- (4) A-III, B-I, C-IV, D-II

Correct Answer: (1) A-IV, B-II, C-I, D-III

Solution: The different types of stamens are classified based on how they are arranged and fused in a flower. - Monadelphous stamens are fused to form a single group, and this is exemplified by the China Rose (*Hibiscus rosa-sinensis*), where the stamens are united by their filaments. - Diadelphous stamens are divided into two groups, one with a larger number of stamens and the other with fewer, as seen in the Pea plant (*Pisum sativum*). - Polyadelphous stamens are grouped into more than two clusters, a feature found in Citrus species (e.g., oranges, lemons). - Epiphyllous stamens, which are borne on the petals or modified leaf structures, are seen in plants like the Lily (*Lilium*). These arrangements are important for the pollination process.

Conclusion: The correct answer is (1) A-IV, B-II, C-I, D-III.

Quick Tip

Floral morphology, including stamen structure, plays a key role in plant identification and taxonomy.

137. Match List-I with List-II

List-I	List-II
A. GLUT-4	I. Hormone
B. Insulin	II. Enzyme
C. Trypsin	III. Intercellular ground substance
D. Collagen	IV. Enables glucose transport into cells

Choose the correct answer from the options given below:

- (1) A-IV, B-I, C-II, D-III
- (2) A-I, B-II, C-III, D-IV
- (3) A-II, B-III, C-IV, D-I
- (4) A-III, B-IV, C-I, D-II

Correct Answer: (1) A-IV, B-I, C-II, D-III

Solution: - GLUT-4 is a glucose transporter that facilitates the entry of glucose into muscle and fat cells, regulated by insulin (A-IV). - Insulin, a hormone produced by the pancreas, helps regulate glucose levels in the blood (B-I). - Trypsin is an enzyme that plays a crucial role in the digestion of proteins in the small intestine (C-II). - Collagen is a protein found in the extracellular matrix and provides structural support to tissues (D-III).

Conclusion: The correct answer is (1) A-IV, B-I, C-II, D-III.

Quick Tip

Each of these components plays a crucial role in maintaining homeostasis and structural integrity in the body, highlighting their importance in medical and biological sciences.

138. Identify the step in tricarboxylic acid cycle, which does not involve oxidation of substrate.

- (1) Malic acid \rightarrow Oxaloacetic acid
- (2) Succinic acid \rightarrow Malic acid
- (3) Succinyl-CoA \rightarrow Succinic acid
- (4) Isocitrate \rightarrow α - ketoglutaric acid

Correct Answer: (3) Succinyl-CoA \rightarrow Succinic acid

Solution: The tricarboxylic acid (TCA) cycle, also known as the Krebs cycle, typically in-

volves oxidation of substrates, where electrons are transferred and energy is released. However, the conversion of Succinyl-CoA to Succinic acid is unique because it involves substrate-level phosphorylation, not oxidation. During this step, a high-energy thioester bond in Succinyl-CoA is cleaved, resulting in the production of ATP or GTP, rather than the removal of electrons. This step is critical for energy production but does not involve direct oxidation of the substrate.

Conclusion: The correct answer is (3) Succinyl-CoA → Succinic acid.

Quick Tip

The TCA cycle is central to cellular respiration, linking carbohydrate, fat, and protein metabolism with the production of ATP, highlighting the interconnected nature of metabolic pathways.

139. Match List I with List II

List I	List II
A. Citric acid cycle	I. Cytoplasm
B. Glycolysis	II. Mitochondrial matrix
C. Electron transport system	III. Intermembrane space of mitochondria
D. Proton gradient	IV. Inner mitochondrial membrane

Choose the correct answer from the options given below:

- (1) A-I, B-II, C-III, D-IV
- (2) A-II, B-I, C-IV, D-III
- (3) A-III, B-IV, C-I, D-II
- (4) A-IV, B-III, C-II, D-I

Correct Answer: (2) A-II, B-I, C-IV, D-III

Solution: - The Citric acid cycle takes place in the mitochondrial matrix, where substrates are oxidized and electrons are generated (A-II). - Glycolysis occurs in the cytoplasm, where glucose is broken down into pyruvate, yielding ATP (B-I). - The electron transport chain is located in the inner mitochondrial membrane, where electrons are transferred and energy is

used to pump protons across the membrane (C-IV). - The proton gradient is formed across the inner mitochondrial membrane, which drives ATP synthesis via chemiosmosis in the intermembrane space of the mitochondria (D-III).

Conclusion: The correct answer is (2) A-II, B-I, C-IV, D-III.

Quick Tip

Each step of cellular respiration is compartmentalized within the cell, optimizing efficiency and control of energy production.

140. Match List I with List II

List I	List II
A. Frederick Griffith	I. Genetic code
B. Francois Jacob & Jacque Monod	II. Semi-conservative mode of DNA replication
C. Har Gobind Khorana	III. Transformation
D. Meselson & Stahl	IV. Lac operon

Choose the correct answer from the options given below:

- (1) A-III, B-II, C-I, D-IV
- (2) A-III, B-IV, C-I, D-II
- (3) A-II, B-III, C-IV, D-I
- (4) A-IV, B-I, C-II, D-III

Correct Answer: (2) A-III, B-IV, C-I, D-II

Solution: - Frederick Griffith is credited with discovering the process of transformation, where genetic material from one organism is taken up by another (A-III). - Francois Jacob and Jacque Monod are known for their discovery of the Lac operon, which regulates gene expression in bacteria (B-IV). - Har Gobind Khorana played a key role in decoding the genetic code, identifying how nucleotide sequences in DNA translate into proteins (C-I). - Meselson and Stahl provided evidence for the semi-conservative replication of DNA, showing that each strand of the original DNA molecule serves as a template for the synthesis of a new strand (D-II).

Conclusion: The correct answer is (2) A-III, B-IV, C-I, D-II.

Quick Tip

Each of these discoveries has played a crucial role in developing modern genetics, showing how scientific inquiry builds upon itself over time.

141. Given below are two statements: Statement I: In C_3 plants, some O_2 binds to RuBisCO, hence CO_2 fixation is decreased.

Statement II: In C_4 plants, mesophyll cells show very little photorespiration while bundle sheath cells do not show photorespiration.

In the light of the above statements, choose the correct answer from the options given below:

- (1) Both Statement I and Statement II are true
- (2) Both Statement I and Statement II are false
- (3) Statement I is true but Statement II is false
- (4) Statement I is false but Statement II is true

Correct Answer: (3) Statement I is true but Statement II is false

Solution: - Statement I is true because in C_3 plants, RuBisCO can bind both O_2 and CO_2 , leading to photorespiration. This reduces the efficiency of CO_2 fixation.

- Statement II is false because although mesophyll cells in C_4 plants show little photorespiration, bundle sheath cells do experience some level of photorespiration, albeit much lower than in C_3 plants.

Conclusion: The correct answer is (3) Statement I is true but Statement II is false.

Quick Tip

C_4 plants have a mechanism to concentrate CO_2 in bundle sheath cells, minimizing photorespiration compared to C_3 plants.

142. Identify the correct description about the given figure:

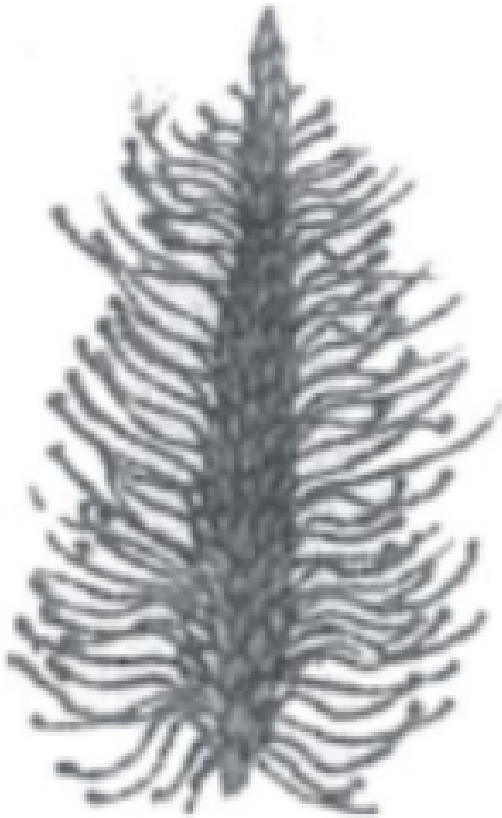

- (1) Wind pollinated plant inflorescence showing flowers with well exposed stamens.
- (2) Water pollinated flowers showing stamens with mucilaginous covering.
- (3) Cleistogamous flowers showing autogamy.
- (4) Compact inflorescence showing complete autogamy

Correct Answer: (1) Wind pollinated plant inflorescence showing flowers with well exposed stamens.

Solution: Wind-pollinated plants typically exhibit flowers with highly exposed stamens that facilitate the dispersal of pollen through air currents. These plants do not rely on attracting pollinators through bright colors or nectar; instead, their floral structures are adapted to maximize the effectiveness of pollen transfer by wind. This includes having prominent, exposed stamens that allow easy release of pollen into the air. This adaptation ensures that pollen can be carried by the wind to other flowers for successful pollination.

Conclusion: The correct answer is (1) Wind pollinated plant inflorescence showing flowers with well exposed stamens.

Quick Tip

Floral adaptations to wind pollination include reduced petal size and increased stamen exposure, optimizing pollen dispersal by air.

143. Match List I with List II

List I	List II
A. Rose	I. Twisted aestivation
B. Pea	II. Perigynous flower
C. Cotton	III. Drupe
D. Mango	IV. Marginal placentation

Choose the correct answer from the options given below:

- (1) A-II, B-IV, C-I, D-III
- (2) A-I, B-II, C-III, D-IV
- (3) A-IV, B-III, C-II, D-I
- (4) A-II, B-III, C-IV, D-I

Correct Answer: (1) A-II, B-IV, C-I, D-III

Solution: - Rose is known for its perigynous flowers, where the floral parts are attached around the base of the ovary (A-II). - Pea plants exhibit marginal placentation, where the ovules are attached along the seams of the ovary (B-IV). - Cotton displays twisted aestivation, where the petals overlap each other in a twisted manner (C-I). - Mangoes are classified as drupes, which are fruits with an outer fleshy part surrounding a single hard pit (D-III). These floral characteristics play significant roles in plant morphology and classification.

Conclusion: The correct answer is (1) A-II, B-IV, C-I, D-III.

Quick Tip

Understanding plant morphology is essential for botanical classification, horticulture, and agriculture.

144. Read the following statements and choose the set of correct statements:

In the members of Phaeophyceae:

- A. Asexual reproduction occurs usually by biflagellate zoospores.
- B. Sexual reproduction is by oogamous method only.
- C. Stored food is in the form of carbohydrates which is either mannitol or laminarin.
- D. The major pigments found are chlorophyll a, c and carotenoids and xanthophyll.
- E. Vegetative cells have a cellulosic wall, usually covered on the outside by gelatinous coating of algin.

Choose the correct answer from the options given below:

- (1) A, B, C and D only
- (2) B, C, D and E only
- (3) A, C, D and E only
- (4) A, B, C and E only

Correct Answer: (3) A, C, D and E only

Solution: - Statement A is correct: Asexual reproduction in Phaeophyceae (brown algae) occurs by biflagellate zoospores.

- Statement B is incorrect: Sexual reproduction in Phaeophyceae is not always oogamous; in some species, it can also be isogamous or anisogamous.

- Statement C is correct: Phaeophyceae store food in the form of carbohydrates, particularly mannitol or laminarin.

- Statement D is correct: The primary pigments in Phaeophyceae are chlorophyll a, chlorophyll c, carotenoids, and xanthophyll.
- Statement E is correct: The vegetative cells of Phaeophyceae have a cellulosic wall and are often covered with a gelatinous coating of algin. These characteristics are crucial for the ecological roles of brown algae in aquatic environments.

Conclusion: The correct answer is (3) A, C, D and E only.

Quick Tip

Phaeophyceae (brown algae) have a variety of pigments and store food as mannitol or laminarin. They also have unique reproductive strategies and cell walls made of cellulose and algin.

145. In an ecosystem if the Net Primary Productivity (NPP) of first trophic level is $100x \text{ kcal m}^{-2}\text{yr}^{-1}$, what would be the GPP (Gross Primary Productivity) of the third trophic level of the same ecosystem?

- (1) $\frac{x}{10} \text{ (kcal m}^{-2}\text{yr}^{-1}\text{)}$
- (2) $x \text{ (kcal m}^{-2}\text{yr}^{-1}\text{)}$
- (3) $10x \text{ (kcal m}^{-2}\text{yr}^{-1}\text{)}$
- (4) $100x/3X \text{ (kcal m}^{-2}\text{yr}^{-1}\text{)}$

Correct Answer: (3) $10x \text{ (kcal m}^{-2}\text{yr}^{-1}\text{)}$

Solution: In ecosystems, energy transfer between trophic levels typically follows the 10% energy rule, where approximately 10% of the energy from one trophic level is transferred to the next. Given that the NPP at the first trophic level is $100x$, the GPP of the second trophic level would be $10x$, accounting for energy losses during metabolic processes. This pattern of energy transfer is consistent across trophic levels, meaning the GPP at the third trophic level would also be approximately $10x$. This highlights the inefficiency of energy transfer as

it moves through the food chain.

Conclusion: The correct answer is (3) $10x$ ($\text{kcal m}^{-2}\text{yr}^{-1}$).

Quick Tip

Energy transfer efficiency between trophic levels is a key concept in ecology, affecting population dynamics and ecosystem stability.

146. Which of the following statement is correct regarding the process of replication in E.coli?

- (1) The DNA dependent DNA polymerase catalyses polymerization in one direction that is $3' \rightarrow 5'$
- (2) The DNA dependent RNA polymerase catalyses polymerization in one direction, that is $5' \rightarrow 3'$
- (3) The DNA dependent DNA polymerase catalyses polymerization in $5' \rightarrow 3'$ as well as $3' \rightarrow 5'$ direction
- (4) The DNA dependent DNA polymerase catalyses polymerization in $5' \rightarrow 3'$ direction

Correct Answer: (4) The DNA dependent DNA polymerase catalyses polymerization in $5' \rightarrow 3'$ direction

Solution: In E. coli, DNA replication is catalyzed by DNA-dependent DNA polymerase, which synthesizes DNA in the $5' \rightarrow 3'$ direction. It can only add nucleotides to the $3'$ end of the growing strand.

Quick Tip

DNA polymerase works in a $5' \rightarrow 3'$ direction, synthesizing new DNA strands and extending the existing strand.

147. Which of the following are fused in somatic hybridization involving two varieties of plants?

- (1) Callus
- (2) Somatic embryos
- (3) Protoplasts
- (4) Pollens

Correct Answer: (3) Protoplasts

Solution: In somatic hybridization, protoplasts (cells without cell walls) from two different plant varieties are fused to form a hybrid. This process is used to combine desirable traits from both varieties.

Quick Tip

Somatic hybridization is a technique used in plant biotechnology to create hybrid plants by fusing protoplasts.

148. Spraying sugarcane crop with which of the following plant growth regulators, increases the length of stem, thus, increasing the yield?

- (1) Auxin
- (2) Gibberellin
- (3) Cytokinin
- (4) Abscisic acid

Correct Answer: (2) Gibberellin

Solution: Gibberellins are plant growth regulators that promote stem elongation and are commonly used in agriculture to increase crop yield, especially in crops like sugarcane.

Quick Tip

Gibberellins are used to stimulate stem elongation and increase the size and yield of crops.

149. Match List I with List II

List I	List II
A. Robert May	I. Species-Area relationships
B. Alexander von Humboldt	II. Long term ecosystem experiment using outdoor plots
C. Paul Ehrlich	III. Global species diversity at about 7 million
D. David Tilman	IV. Rivet popper hypothesis

Choose the correct answer from the options given below:

- (1) A-II, B-III, C-I, D-IV
- (2) A-III, B-I, C-IV, D-II
- (3) A-I, B-III, C-II, D-IV
- (4) A-III, B-IV, C-II, D-I

Correct Answer: (2) A-III, B-I, C-IV, D-II

Solution: Robert May is renowned for his work on mathematical models in ecology, predicting global species diversity estimates, not specifically at 7 million but his work underpins many modern ecological predictions (A-III). Alexander von Humboldt is historically significant for his exploration and description of the relationship between species and area (B-I), laying foundational concepts in biogeography. Paul Ehrlich is known for his contributions to environmental science and conservation, notably his rivet popper hypothesis which suggests that ecosystem resilience decreases with the loss of species (C-IV). David Tilman's research focuses on biodiversity and ecosystem functioning, conducting long-term ecological experiments using outdoor plots to understand species interactions and community dynamics (D-II). This understanding of ecological and environmental science pioneers and their theories is crucial for students and researchers in these fields, providing a framework for ongoing studies and conservation efforts.

Quick Tip

Linking historical figures to their scientific contributions provides a deeper understanding of the development and current state of ecological and environmental sciences.

150. The DNA present in chloroplast is:

- (1) Linear, double stranded
- (2) Circular, double stranded
- (3) Linear, single stranded
- (4) Circular, single stranded

Correct Answer: (2) Circular, double stranded

Solution:

The DNA present in chloroplasts is circular and double-stranded, similar to the DNA found in prokaryotes. This is one of the key features of plastids, as they are thought to have evolved from endosymbiotic bacteria.

Thus, the correct answer is option (2).

Quick Tip

Chloroplast DNA is circular and double-stranded, reflecting its prokaryotic origin.

151. Match List I with List II:

List I	List II
A. Common cold	I. Plasmodium
B. Haemozoin	II. Typhoid
C. Widal test	III. Rhinoviruses
D. Allergy	IV. Dust mites

Choose the correct answer from the options given below:

- (1) A-II, B-IV, C-III, D-I

- (2) A-I, B-III, C-II, D-IV
- (3) A-III, B-I, C-II, D-IV
- (4) A-IV, B-II, C-III, D-I

Correct Answer: (3) A-III, B-I, C-II, D-IV

Solution: The common cold is caused by rhinoviruses (A-III), which are a group of viruses known for their role in upper respiratory infections. Haemozoin is a byproduct of hemoglobin processing by Plasmodium, the parasite responsible for malaria (B-I). The Widal test is used for diagnosing typhoid fever, caused by the bacterium Salmonella typhi (C-II). Allergies related to dust mites involve immune reactions to proteins in the waste products of dust mites (D-IV). This matching highlights important clinical diagnostics and etiological agents in infectious diseases and allergic reactions.

Quick Tip

Understanding the causative agents of diseases and their diagnostic tests is crucial for effective disease management and prevention.

152. Match List I with List II:

List I	List II
A. Cocaine	I. Effective sedative in surgery
B. Heroin	II. Cannabis sativa
C. Morphine	III. Erythroxyllum
D. Marijuana	IV. Papaver somniferum

Choose the correct answer from the options given below:

- (1) A-IV, B-III, C-I, D-II
- (2) A-I, B-III, C-II, D-IV
- (3) A-II, B-I, C-III, D-IV
- (4) A-III, B-IV, C-I, D-II

Correct Answer: (4) A-III, B-IV, C-I, D-II

Solution: Cocaine is derived from the *Erythroxylum coca* plant (A-III), heroin is processed from morphine, which comes from *Papaver somniferum*, the opium poppy (B-IV), morphine is also derived from *Papaver somniferum* (C-I), and marijuana comes from *Cannabis sativa* (D-II). This question tests knowledge of the source plants of various drugs, important for understanding their effects and regulation.

Quick Tip

Knowledge of the origins and effects of psychoactive substances can aid in their proper regulation and in public health education.

153. Match List I with List II:

List I	List II
A. Fibrous joints	I. Adjacent vertebrae, limited movement
B. Cartilaginous joints	II. Humerus and Pectoral girdle, rotational movement
C. Hinge joints	III. Skull, don't allow any movement
D. Ball and socket joints	IV. Knee, help in locomotion

Choose the correct answer from the options given below:

- (1) A-IV, B-II, C-III, D-I
- (2) A-I, B-III, C-II, D-IV
- (3) A-II, B-III, C-I, D-IV
- (4) A-III, B-I, C-IV, D-II

Correct Answer: (4) A-III, B-I, C-IV, D-II

Solution: Fibrous joints, such as those in the skull, allow no movement (A-III). Cartilaginous joints, like those between adjacent vertebrae, permit limited movement (B-I). Hinge joints, such as the knee, allow movement primarily in one plane (C-IV). Ball and socket joints, found in the shoulder (humerus and pectoral girdle), allow rotational and other movements (D-II). This knowledge is crucial in fields like orthopedics and physical therapy.

Quick Tip

Understanding the types of joints and their movements can aid in diagnosing and treating musculoskeletal disorders.

154. Which of the following are Autoimmune disorders?

- A. Myasthenia gravis
- B. Rheumatoid arthritis
- C. Gout
- D. Muscular dystrophy
- E. Systemic Lupus Erythematosus (SLE)

Choose the most appropriate answer from the options given below:

- (1) A, B & D only
- (2) A, B & E only
- (3) B, C & E only
- (4) C, D & E only

Correct Answer: (2) A, B & E only

Solution: Autoimmune disorders are conditions where the immune system mistakenly attacks the body's own tissues. Myasthenia gravis (A) involves antibodies that block or destroy muscle receptor cells, Rheumatoid arthritis (B) is characterized by immune-mediated destruction of joint linings, and Systemic Lupus Erythematosus (E) affects multiple organs with widespread inflammation and tissue damage. Gout and Muscular dystrophy, however, are not autoimmune; gout is a metabolic disorder and muscular dystrophy is a genetic disorder.

Quick Tip

Recognition of autoimmune mechanisms can aid in the development of targeted therapies that modulate the immune response.

155. Which of the following is not a component of the Fallopian tube?

- (1) Uterine fundus
- (2) Isthmus
- (3) Infundibulum
- (4) Ampulla

Correct Answer: (1) Uterine fundus

Solution: The uterine fundus is not a component of the Fallopian tube (1); it is the top part of the uterus, located above the openings of the Fallopian tubes. The Fallopian tubes, responsible for transporting ova from the ovary to the uterus, include the infundibulum, isthmus, and ampulla, but not the uterine fundus. Understanding the anatomy of the female reproductive system is crucial in fields such as gynecology and reproductive biology.

Quick Tip

Knowledge of reproductive anatomy is essential for diagnosing and treating reproductive health issues.

156. The flippers of the Penguins and Dolphins are an example of:

- (1) Adaptive radiation
- (2) Natural selection
- (3) Convergent evolution
- (4) Divergent evolution

Correct Answer: (3) Convergent evolution

Solution: The flippers of penguins and dolphins are a classic example of convergent evolution, where different species develop similar physical features independently because they live in similar environments or have similar ecological roles. Penguins are birds and dolphins are mammals; their evolutionary paths are very different, yet both have developed flippers as

adaptations to an aquatic lifestyle. This demonstrates how similar selective pressures can lead to similar adaptations in diverse groups of organisms.

Quick Tip

Convergent evolution illustrates how environmental pressures can guide the evolutionary path leading to similar adaptations in unrelated species.

157. Match List I with List II:

List I	List II
A. α -I antitrypsin	I. Cotton bollworm
B. Cry IAb	II. ADA deficiency
C. Cry IAc	III. Emphysema
D. Enzyme replacement therapy	IV. Corn borer

Choose the correct answer from the options given below:

- (1) A-II, B-I, C-IV, D-III
- (2) A-III, B-I, C-II, D-IV
- (3) A-III, B-IV, C-I, D-II
- (4) A-II, B-IV, C-I, D-III

Correct Answer: (3) A-III, B-IV, C-I, D-II

Solution: α -I antitrypsin is a protein that protects tissues from enzymes of inflammatory cells, especially in the lungs; deficiency can lead to emphysema (A-III). Cry IAb and Cry IAc are insecticidal proteins produced by *Bacillus thuringiensis*; Cry IAb targets the corn borer (B-IV) and Cry IAc targets the cotton bollworm (C-I). Enzyme replacement therapy is used to treat various deficiencies, such as ADA deficiency (D-II). This question tests knowledge of biotechnological applications and their impact on medicine and agriculture.

Quick Tip

Biotechnology harnesses cellular and biomolecular processes to develop technologies and products that help improve our lives and the health of our planet.

158. The following diagram showing restriction sites in E. coli cloning vector pBR322. Find the role of 'X' and 'Y' genes:

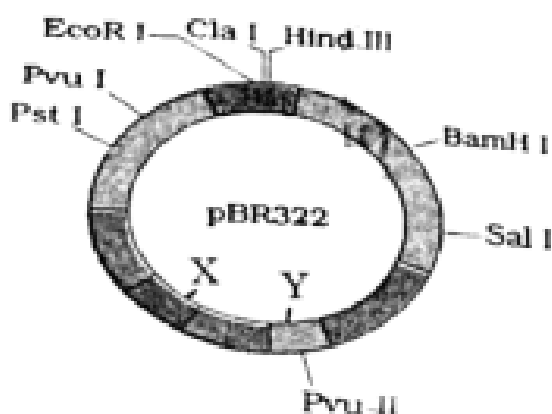

- (1) The gene 'X' is responsible for resistance to antibiotics and 'Y' for protein involved in the replication of Plasmid.
- (2) The gene 'X' is responsible for controlling the copy number of the linked DNA and 'Y' for protein involved in the replication of Plasmid.
- (3) The gene 'X' is for protein involved in replication of Plasmid and 'Y' for resistance to antibiotics.
- (4) Gene 'X' is responsible for recognitions sites and 'Y' is responsible for antibiotic resistance.

Correct Answer: (2) The gene 'X' is responsible for controlling the copy number of the linked DNA and 'Y' for protein involved in the replication of Plasmid.

Solution: In the pBR322 vector, gene 'X' typically refers to elements like the *rop* gene that helps control the plasmid's copy number within the host cell, whereas gene 'Y' could refer

to a gene like the rep gene involved in the initiation of plasmid DNA replication. This setup ensures that the plasmid can maintain itself efficiently within bacterial cells, crucial for its use in cloning and genetic engineering.

Quick Tip

Understanding plasmid functions such as copy number control and replication is critical in biotechnology and genetic engineering.

159. Given below are two statements: One is labelled as Assertion (A) and the other is labelled as Reason (R): Assertion (A): Breast-feeding during initial period of infant growth is recommended by doctors for bringing a healthy baby.

Reason (R): Colostrum contains several antibodies absolutely essential to develop resistance for the new born baby.

In the light of the above statements, choose the most appropriate answer from the options given below: (1) Both A and R are correct and R is the correct explanation of A

(2) Both A and R are correct but R is NOT the correct explanation of A

(3) A is correct but R is not correct

(4) A is not correct but R is correct

Correct Answer: (1) Both A and R are correct and R is the correct explanation of A

Solution: Both statements are correct and Reason (R) is the correct explanation for Assertion (A). Breastfeeding is highly recommended as it not only provides complete nutrition but also passes essential antibodies found in colostrum, which protect the newborn against various diseases, boosting their immune system early in life.

Quick Tip

The benefits of breastfeeding extend beyond basic nutrition, including enhanced immunity and improved health outcomes for babies.

160. The “Ti plasmid” of *Agrobacterium tumefaciens* stands for (1) Tumour inhibiting plasmid

- (2) Tumor independent plasmid
- (3) Tumor inducing plasmid
- (4) Temperature independent plasmid

Correct Answer: (3) Tumor inducing plasmid

Solution: The “Ti plasmid” in *Agrobacterium tumefaciens* stands for “tumor inducing” plasmid. This plasmid is responsible for transferring part of its DNA to plant cells, leading to the formation of tumors or galls. This mechanism has been harnessed in genetic engineering to introduce new genes into plants.

Quick Tip

The manipulation of the Ti plasmid has significant applications in biotechnology, especially in creating genetically modified plants.

161. Match List I with List II

List I	List II
A. Pleurobrachia	I. Mollusca
B. Radula	II. Ctenophora
C. Stomochord	III. Osteichthyes
D. Air bladder	IV. Hemichordata

Choose the correct answer from the options given below:

- (1) A-IV, B-II, C-III, D-I
- (2) A-II, B-I, C-IV, D-III
- (3) A-II, B-IV, C-I, D-III
- (4) A-IV, B-III, C-II, D-I

Correct Answer: (2) A-II, B-I, C-IV, D-III

Solution: Pleurobrachia belongs to the phylum Ctenophora, known for their distinctive comb-like cilia used for movement (A-II). The radula is a structure found in mollusks, used for feeding by scraping or cutting food (B-I). The stomochord is a structure in Hemichordata, often confused with chordates due to its name but distinct in function and form (C-IV). The air bladder, or swim bladder, is a gas-filled organ that helps bony fish (Osteichthyes) maintain buoyancy (D-III). This question tests knowledge of biological classification and the anatomical features of different animal phyla.

Quick Tip

Familiarity with the unique structures of animal phyla aids in understanding evolutionary relationships and adaptations.

162. Given below are some stages of human evolution. Arrange them in correct sequence. (Past to Recent)

- A. Homo habilis
- B. Homo sapiens
- C. Homo neanderthalensis
- D. Homo erectus

Choose the correct sequence of human evolution from the options given below:

- (1) D-A-C-B
- (2) B-A-D-C

(3) C-B-D-A

(4) A-D-C-B

Correct Answer: (4) A-D-C-B

Solution: The correct chronological sequence of human evolution, from earliest to most recent, is: Homo habilis (A) as one of the earliest known species using tools, Homo erectus (D) known for significant brain enlargement and use of fire, Homo neanderthalensis (C) known for robust build and adaptability to cold climates, and Homo sapiens (B) which represents modern humans, known for advanced tools and complex social structures.

Quick Tip

Studying human evolution provides insights into our biological history and the evolutionary processes that influence our current form and behaviors.

163. Which of the following is not a steroid hormone?

(1) Cortisol

(2) Testosterone

(3) Progesterone

(4) Glucagon

Correct Answer: (4) Glucagon

Solution: Glucagon is a peptide hormone, not a steroid hormone. It is produced by the alpha cells of the pancreas and plays a critical role in regulating blood glucose levels by promoting the breakdown of glycogen to glucose in the liver. Steroid hormones, like cortisol, testosterone, and progesterone, are derived from cholesterol and are involved in a range of physiological processes from stress response to reproductive functions. Understanding the differences between peptide and steroid hormones is fundamental in endocrinology, empha-

sizing their distinct synthesis pathways and mechanisms of action.

Quick Tip

Steroid hormones can cross cell membranes due to their lipophilic nature, binding to intracellular receptors, unlike peptide hormones that bind to surface receptors.

164. In both sexes of cockroach, a pair of jointed filamentous structures called anal cerci are present on:

- (1) 5th segment
- (2) 10th segment
- (3) 8th and 9th segment
- (4) 11th segment

Correct Answer: (2) 10th segment

Solution: In cockroaches, the anal cerci are located at the 10th segment of the abdomen. These structures are sensitive to air currents, helping the cockroach detect movements around it, which is crucial for its survival as it allows the cockroach to respond quickly to potential threats. This anatomical feature is an example of how morphology can be linked to behavioral adaptations in insects.

Quick Tip

Anal cerci are used in various insects not only for sensing but also in mating rituals, showcasing the diverse functions of similar structures.

165. Which one of the following factors will not affect the Hardy-Weinberg equilibrium?

- (1) Genetic recombination
- (2) Genetic drift

- (3) Gene migration
- (4) Constant gene pool

Correct Answer: (4) Constant gene pool

Solution: The Hardy-Weinberg equilibrium assumes no change in allele frequencies due to factors like migration, mutation, or selection. A constant gene pool (4), which implies no change in allele frequencies, aligns perfectly with the Hardy-Weinberg conditions and therefore does not disrupt the equilibrium. This principle is a cornerstone of population genetics, providing a foundation for understanding genetic variation and the effects of evolutionary processes.

Quick Tip

Understanding the Hardy-Weinberg equilibrium helps in studying population genetics and the factors that cause evolutionary change.

166. Match List I with List II:

List I	List II
A. Pons	I. Provides additional space for Neurons, regulates posture and balance.
B. Hypothalamus	II. Controls respiration and gastric secretions.
C. Medulla	III. Connects different regions of the brain.
D. Cerebellum	IV. Neuro secretory cells

Choose the correct answer from the options given below:

- (1) A-II, B-III, C-I, D-IV
- (2) A-III, B-IV, C-II, D-I
- (3) A-I, B-III, C-II, D-IV
- (4) A-II, B-I, C-III, D-IV

Correct Answer: (2) A-III, B-IV, C-II, D-I

Solution: The pons acts as a bridge connecting different regions of the brain, facilitating communication between them (A-III). The hypothalamus contains neurosecretory cells that

are crucial for hormone production and regulation of the autonomic nervous system (B-IV). The medulla controls essential autonomic functions such as respiration and digestion (C-II). The cerebellum is critical for motor control, including the regulation of posture and balance (D-I). This question tests knowledge of the functions and locations of major brain structures, important for understanding neural control and integration.

Quick Tip

The central nervous system's complexity is organized functionally and anatomically to optimize neural processing and bodily control.

167. Match List I with List II:

List I	List II
A. Down's syndrome	I. 11 th chromosome
B. α -Thalassemia	II. X chromosome
C. β -Thalassemia	III. 21 st chromosome
D. Klinefelter's syndrome	IV. 16 th chromosome

- (1) A-I, B-II, C-III, D-IV
- (2) A-II, B-III, C-IV, D-I
- (3) A-III, B-IV, C-I, D-II
- (4) A-IV, B-I, C-II, D-III

Correct Answer: (3) A-III, B-IV, C-I, D-II

Solution: Down's syndrome is associated with an extra copy of the 21st chromosome (A-III), α -Thalassemia is linked to defects on the 16th chromosome (B-IV), β -Thalassemia involves the 11th chromosome (C-I), and Klinefelter's syndrome is characterized by an extra 'X' chromosome (D-II). This question helps in understanding genetic disorders and their chromosomal bases.

Quick Tip

Accurate knowledge of genetic disorders and their chromosomal links is crucial for diagnosis and genetic counseling.

168. Which one is the correct product of DNA dependent RNA polymerase to the given template?

3' TACATGGCAAATATCCATTCA 5'

(1) 5' AUGUACCGUUUUAUAGGUAAGU 3'

(2) 5' AUGUAAAGUUUUAUAGGUAAGU 3'

(3) 5' AUGUACCGUUUUAUAGGGAAGU 3'

(4) 5' ATGTACCGTTTATAGGTAAGT 3'

Correct Answer: (1) 5' AUGUACCGUUUUAUAGGUAAGU 3'

Solution: The correct RNA sequence is synthesized by RNA polymerase which reads the DNA template strand from 3' to 5' and synthesizes RNA from 5' to 3'. The RNA sequence matching the DNA template 'TACATGGCAAATATCCATTCA' would be 'AUGUACCGU-UUAUAGGUAAGU', where each DNA base is transcribed to its complementary RNA base (A to U, T to A, C to G, G to C).

Quick Tip

Understanding transcription fidelity is crucial for techniques in molecular biology, such as RNA synthesis and gene expression studies.

169. Given below are two statements: one is labelled as Assertion (A) and the other is labelled as Reason (R):

Assertion (A): FSH acts upon ovarian follicles in female and Leydig cells in male.

Reason (R): Growing ovarian follicles secrete estrogen in female while interstitial cells secrete androgen in male human being.

In the light of the above statements, choose the correct answer from the options given below:

- (1) Both A and R are true and R is the correct explanation of A
- (2) Both A and R are true but R is NOT the correct explanation of A
- (3) A is true but R is false
- (4) A is false but R is true

Correct Answer: (4) A is false but R is true

Solution: Assertion (A) is false because FSH acts on Sertoli cells in males, not Leydig cells. Leydig cells are stimulated by LH, not FSH. Reason (R) is true as it correctly states the hormones secreted by the ovarian follicles and interstitial cells in females and males respectively.

Quick Tip

Understanding the specific roles of FSH and LH in the reproductive systems of both genders is crucial for studies in endocrinology and reproductive health.

170. Which of the following is not a natural/traditional contraceptive method? (1) Coitus interruptus

- (2) Periodic abstinence
- (3) Lactational amenorrhea
- (4) Vaults

Correct Answer: (4) Vaults

Solution: Vaults, or cervical caps, are not traditional methods; they are barrier methods of contraception that involve a device placed over the cervix to prevent sperm from entering the uterus. The other options listed are considered natural or traditional methods, relying on behavior rather than devices.

Quick Tip

Understanding the range of contraceptive methods available can aid individuals in choosing the most appropriate method for their needs.

171. Match List I with List II

List I	List II
A. Non-medicated IUD	I. Multiload 375
B. Copper releasing IUD	II. Progestogens
C. Hormone releasing IUD	III. Lippes loop
D. Implants	IV. LNG-20

Choose the correct answer from the options given below:

- (1) A-III, B-I, C-II, D-IV
- (2) A-I, B-III, C-IV, D-II
- (3) A-IV, B-I, C-II, D-III
- (4) A-III, B-I, C-IV, D-II

Correct Answer: (4) A-III, B-I, C-IV, D-II

Solution: The correct associations of IUD types and implants are as follows: - Non-medicated IUDs like the Lippes loop (A-III) are simple devices that don't release any hormones or copper. - Copper releasing IUDs, such as Multiload 375 (B-I), release copper to enhance contraceptive effectiveness. - Hormone releasing IUDs, such as LNG-20 (C-IV), release the hormone levonorgestrel to help prevent pregnancy. - Implants like those releasing progestogens (D-II) are subdermal devices that provide long-lasting contraception. These devices demonstrate the variety of contraceptive technologies available and their mechanisms of action.

Conclusion: The correct answer is (4) A-III, B-I, C-IV, D-II.

Quick Tip

Choosing the right contraceptive method involves considering both the mechanism of action and individual health needs.

172. Consider the following statements:

- A. Annelids are true coelomates
- B. Poriferans are pseudocoelomates
- C. Aschelminthes are acoelomates
- D. Platyhelminthes are pseudocoelomates

Choose the correct answer from the options given below:

- (1) B only
- (2) A only
- (3) C only
- (4) D only

Correct Answer: (2) A only

Solution: Annelids are classified as true coelomates, meaning they have a body cavity fully lined with mesoderm (A). - Poriferans do not possess any body cavity and thus cannot be considered pseudocoelomates (B is false). - Aschelminthes are pseudocoelomates, not acoelomates (C is false). - Platyhelminthes are acoelomates, lacking a body cavity (D is false). Understanding these distinctions is important for categorizing and studying various animal groups.

Conclusion: The correct answer is (2) A only.

Quick Tip

Accurate classification based on body cavity type is fundamental in understanding animal phylogeny and evolutionary relationships.

173. Three types of muscles are given as a, b, and c. Identify the correct matching pair along with their location in the human body:

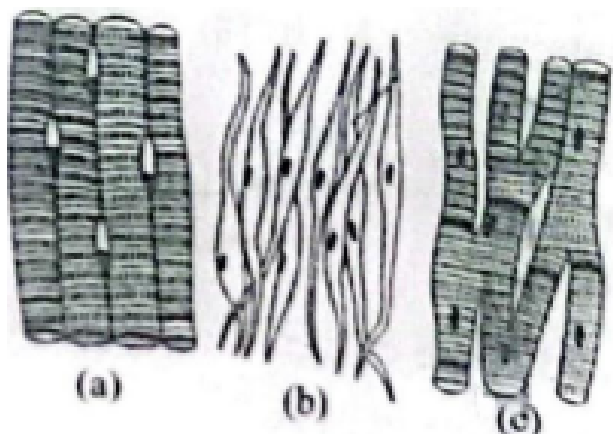

Name of muscle/location

- (1) (a) Smooth - Toes, (b) Skeletal – Legs, (c) Cardiac – Heart
- (2) (a) Skeletal - Triceps, (b) Smooth – Stomach, (c) Cardiac – Heart
- (3) (a) Skeletal - Biceps, (b) Involuntary – Intestine, (c) Smooth – Heart
- (4) (a) Involuntary – Nose tip, (b) Skeletal – Bone, (c) Cardiac – Heart

Correct Answer: (2) (a) Skeletal - Triceps, (b) Smooth – Stomach, (c) Cardiac – Heart

Solution: The correct matching of muscle types to their locations in the human body is as follows: - (a) Skeletal muscles like the triceps are located in the arms, enabling voluntary movement. - (b) Smooth muscles are found in organs such as the stomach, where they help in involuntary functions like digestion. - (c) Cardiac muscle is found only in the heart, where it is responsible for the contraction and pumping of blood. This knowledge is essential for understanding the function and role of muscle tissues in human physiology.

Conclusion: The correct answer is (2) (a) Skeletal - Triceps, (b) Smooth – Stomach, (c) Cardiac – Heart.

Quick Tip

Knowing the function and location of different muscle types helps in understanding their roles in health and disease.

174. Following are the stages of the pathway for conduction of an action potential through the heart:

- A. AV bundle
- B. Purkinje fibres
- C. AV node
- D. Bundle branches
- E. SA node

Choose the correct sequence of the pathway from the options given below:

- (1) E-C-A-D-B
- (2) A-E-C-B-D
- (3) B-D-E-C-A
- (4) E-A-D-B-C

Correct Answer: (1) E-C-A-D-B

Solution: The correct sequence for the conduction of an action potential through the heart begins at the sinoatrial (SA) node (E), the natural pacemaker of the heart. The electrical impulse travels from the SA node to the atrioventricular (AV) node (C), then through the AV bundle (A), down the bundle branches (D), and finally to the Purkinje fibers (B), which deliver the impulse to the ventricular muscle for contraction. This orderly conduction system ensures synchronized heartbeats and effective blood circulation.

Conclusion: The correct answer is (1) E-C-A-D-B.

Quick Tip

Understanding the conduction pathway of the heart is vital for diagnosing and treating arrhythmias and other cardiac disorders.

175. Match List I with List II:

List I	List II
A. Lipase	I. Peptide bond
B. Nuclease	II. Ester bond
C. Protease	III. Glycosidic bond
D. Amylase	IV. Phosphodiester bond

Choose the correct answer from the options given below:

- (1) A-IV, B-II, C-III, D-I
- (2) A-III, B-II, C-I, D-IV
- (3) A-II, B-IV, C-I, D-III
- (4) A-IV, B-I, C-III, D-II

Correct Answer: (3) A-II, B-IV, C-I, D-III

Solution: Lipase acts on ester bonds found in lipids (A-II). Nuclease cuts phosphodiester bonds in nucleic acids (B-IV). Protease breaks peptide bonds in proteins (C-I). Amylase breaks down glycosidic bonds in starch (D-III). This question assesses understanding of enzyme specificity and the biochemical reactions they catalyze.

Conclusion: The correct answer is (3) A-II, B-IV, C-I, D-III.

Quick Tip

Recognizing the specific substrates and actions of different enzymes is key in biochemistry, especially for applications in medicine and biotechnology.

176. Match List I with List II:

List I	List II
A. Axoneme	I. Centriole
B. Cartwheel pattern	II. Cilia and flagella
C. Crista	III. Chromosome
D. Satellite	IV. Mitochondria

Choose the correct answer from the options given below:

- (1) A-IV, B-III, C-II, D-I
- (2) A-IV, B-II, C-III, D-I
- (3) A-II, B-IV, C-I, D-III
- (4) A-II, B-I, C-IV, D-III

Correct Answer: (4) A-II, B-I, C-IV, D-III

Solution: Axoneme is the structural core of cilia and flagella (A-II), involved in their movement. The cartwheel pattern is associated with the centriole structure (B-I), seen during centriole replication. Cristae are folds within the mitochondria that increase surface area for ATP production (C-IV). Satellites are repetitive DNA sequences found near centromeres of chromosomes (D-III). These cellular structures are key for understanding various functions within the cell.

Conclusion: The correct answer is (4) A-II, B-I, C-IV, D-III.

Quick Tip

Exploring cellular structures in detail can lead to a better understanding of cellular functions and their implications in health and disease.

177. Match List I with List II:

List I (Sub Phases of Prophase I)	List II (Specific Characters)
A. Diakinesis	I. Synaptonemal complex formation
B. Pachytene	II. Completion of terminalisation of chiasmata
C. Zygotene	III. Chromosomes look like thin threads
D. Leptotene	IV. Appearance of recombination nodules

Choose the correct answer from the options given below:

- (1) A-IV, B-II, C-III, D-I
- (2) A-I, B-II, C-IV, D-III
- (3) A-II, B-IV, C-I, D-III
- (4) A-IV, B-III, C-II, D-I

Correct Answer: (3) A-II, B-IV, C-I, D-III

Solution: Diakinesis is marked by the completion of terminalisation of chiasmata (A-II), where chromosomes prepare for segregation. Pachytene features the appearance of recombination nodules, which are crucial for crossing over (B-IV). During Zygotene, synaptonemal complexes form, facilitating chromosome pairing (C-I). In Leptotene, chromosomes first become visible as thin threads (D-III). These processes are integral to genetic recombination and chromosome behavior during meiosis.

Conclusion: The correct answer is (3) A-II, B-IV, C-I, D-III.

Quick Tip

Each phase of meiosis has distinctive events that are crucial for accurate genetic segregation and variation.

178. Which of the following factors are favorable for the formation of oxyhaemoglobin in alveoli?

- (1) High pO₂ and High pCO₂
- (2) High pO₂ and Lesser H⁺ concentration
- (3) Low pCO₂ and High H⁺ concentration
- (4) Low pCO₂ and High temperature

Correct Answer: (2) High pO₂ and Lesser H⁺ concentration

Solution: High partial pressure of oxygen (pO_2) and lower hydrogen ion (H^+) concentration facilitate the formation of oxyhaemoglobin in the alveoli. High pO_2 increases the saturation of haemoglobin with oxygen, while lower H^+ concentration reduces the Bohr effect, enhancing the uptake of oxygen. These conditions are critical for effective oxygen loading in the lungs.

Conclusion: The correct answer is (2) High pO_2 and Lesser H^+ concentration.

Quick Tip

Understanding the conditions that favor oxyhaemoglobin formation can help in assessing respiratory efficiency and the oxygen-carrying capacity of the blood.

179. Match List I with List II:

List I	List II
A. Pterophyllum	I. Hag fish
B. Myxine	II. Saw fish
C. Pristis	III. Angel fish
D. Exocoetus	IV. Flying fish

Choose the correct answer from the options given below:

- (1) A-II, B-I, C-III, D-IV
- (2) A-III, B-I, C-II, D-IV
- (3) A-IV, B-I, C-II, D-III
- (4) A-III, B-II, C-I, D-IV

Correct Answer: (2) A-III, B-I, C-II, D-IV

Solution: - Pterophyllum is commonly recognized as the angel fish (A-III), a freshwater fish known for its elegant, flat body. - Myxine, also called hagfish (B-I), are jawless marine animals famous for secreting slime. - Pristis refers to the sawfish (C-II), which has a distinctive, long rostrum resembling a saw. - Exocoetus, known as the flying fish (D-IV), is famous for

its ability to glide above the water's surface to evade predators. This question tests knowledge about fish species and their unique characteristics, important for studies in marine biology and ecology.

Conclusion: The correct answer is (2) A-III, B-I, C-II, D-IV.

Quick Tip

Linking scientific names with common names enhances understanding of biodiversity and aids in more effective communication in biological sciences.

180. Match List I with List II:

List I	List II
A. Typhoid	I. Fungus
B. Leishmaniasis	II. Nematode
C. Ringworm	III. Protozoa
D. Filariasis	IV. Bacteria

Choose the correct answer from the options given below:

- (1) A-I, B-III, C-II, D-IV
- (2) A-IV, B-III, C-I, D-II
- (3) A-III, B-I, C-IV, D-II
- (4) A-II, B-IV, C-III, D-I

Correct Answer: (2) A-IV, B-III, C-I, D-II

Solution: - Typhoid is caused by the bacterium *Salmonella typhi* (A-IV). - Leishmaniasis is caused by protozoan parasites of the genus *Leishmania* (B-III). - Ringworm is caused by fungi, not worms, and affects the skin, hair, and nails (C-I). - Filariasis is caused by nematodes (roundworms) of the family *Filarioidea* (D-II), which are transmitted to humans through mosquito bites. This question emphasizes the importance of understanding the

causative agents of diseases, which is vital for accurate diagnosis and treatment.

Conclusion: The correct answer is (2) A-IV, B-III, C-I, D-II.

Quick Tip

Correct identification of the causative agents of diseases is essential for appropriate treatment and control measures.

181. Which of the following statements is incorrect?

- (1) A bio-reactor provides optimal growth conditions for achieving the desired product
- (2) Most commonly used bio-reactors are of stirring type
- (3) Bio-reactors are used to produce small scale bacterial cultures
- (4) Bio-reactors have an agitator system, an oxygen delivery system, and foam control system

Correct Answer: (3) Bio-reactors are used to produce small scale bacterial cultures

Solution: The statement that bio-reactors are used to produce small-scale bacterial cultures is incorrect (3). Bio-reactors are typically designed for large-scale production of biological products, including pharmaceuticals, chemicals, and food products. They are engineered to provide optimal environmental conditions such as temperature, pH, and oxygen levels, which are crucial for achieving high yields in industrial-scale production.

Conclusion: The correct answer is (3) Bio-reactors are used to produce small scale bacterial cultures.

Quick Tip

Bio-reactors play a crucial role in the biotechnology industry, enabling the mass production of biologically derived substances.

182. Given below are two statements:

Statement I: In the nephron, the descending limb of the loop of Henle is impermeable to water and permeable to electrolytes.

Statement II: The proximal convoluted tubule is lined by simple columnar brush border epithelium and increases the surface area for reabsorption.

In the light of the above statements, choose the correct answer from the option given below:

- (1) Both Statement I and Statement II are true
- (2) Both Statement I and Statement II are false
- (3) Statement I is true but Statement II is false
- (4) Statement I is false but Statement II is true

Correct Answer: (2) Both Statement I and Statement II are false

Solution: Statement I is false because the descending limb of the loop of Henle is actually permeable to water, which allows water to be reabsorbed into the bloodstream, but it is largely impermeable to solutes. Statement II is also false; the proximal convoluted tubule is lined by simple cuboidal epithelium, not columnar, and this lining helps increase surface area for reabsorption of water and solutes. This distinction is important for understanding renal physiology and the processes of filtration and reabsorption in the nephron.

Conclusion: The correct answer is (2) Both Statement I and Statement II are false.

Quick Tip

Accurate knowledge of nephron structure and function is crucial for understanding kidney function and diagnosing kidney-related diseases.

183. Given below are two statements:

Statement I: The presence or absence of hymen is not a reliable indicator of virginity.

Statement II: The hymen is torn during the first coitus only.

In the light of the above statements, choose the correct answer from the options given below:

- (1) Both Statement I and Statement II are true

- (2) Both Statement I and Statement II are false
- (3) Statement I is true but Statement II is false

Correct Answer: (3) Statement I is true but Statement II is false

Solution: Statement I is true because the hymen’s appearance can vary greatly between individuals, and it can be absent, stretched, or torn by activities other than sexual intercourse. Statement II is false, as the hymen can be elastic or have natural openings that do not tear during the first sexual encounter. The concept of using the hymen as a marker for virginity is a myth and does not hold scientific merit. This highlights the need for better understanding of human anatomy and debunking cultural myths.

Conclusion: The correct answer is (3) Statement I is true but Statement II is false.

Quick Tip

Educational efforts are essential to dispel myths regarding the hymen and virginity, promoting a more scientifically accurate understanding of human anatomy.

184. Match List I with List II:

List I	List II
A. Expiratory capacity	I. Expiratory reserve volume + Tidal vol + Inspiratory reserve vol
B. Functional residual capacity	II. Tidal volume + Expiratory reserve volume
C. Vital capacity	III. Tidal volume + Inspiratory reserve volume
D. Inspiratory capacity	IV. Expiratory reserve volume + Residual volume

Choose the correct answer from the options given below:

- (1) A-II, B-IV, C-I, D-III
- (2) A-III, B-II, C-IV, D-I
- (3) A-II, B-I, C-IV, D-III
- (4) A-I, B-III, C-II, D-IV

Correct Answer: (1) A-II, B-IV, C-I, D-III

Solution: - Expiratory capacity (A) is calculated as the sum of tidal volume and expiratory

reserve volume (A-II), representing the total volume of air expelled from the lungs during a normal exhalation, followed by a forced exhalation. - Functional residual capacity (B) refers to the sum of expiratory reserve volume and residual volume (B-IV), representing the air volume remaining in the lungs after a normal exhalation. - Vital capacity (C) refers to the maximum volume of air that can be exhaled after a maximal inhalation, including tidal volume, inspiratory reserve volume, and expiratory reserve volume (C-I). - Inspiratory capacity (D) is the sum of tidal volume and inspiratory reserve volume (D-III), representing the total volume of air that can be inhaled following a normal exhalation. These capacities are important for understanding respiratory function and diagnosing various pulmonary conditions.

Conclusion: The correct answer is (1) A-II, B-IV, C-I, D-III.

Quick Tip

Lung capacity measurements are essential in diagnosing and monitoring respiratory conditions such as asthma and COPD.

185. Following are the stages of cell division:

- A. Gap 2 phase
- B. Cytokinesis
- C. Synthesis phase
- D. Karyokinesis
- E. Gap 1 phase

Choose the correct sequence of stages from the options given below:

- (1) C-E-D-A-B
- (2) E-B-D-A-C
- (3) B-D-E-A-C
- (4) E-C-A-D-B

Correct Answer: (4) E-C-A-D-B

Solution: The correct sequence of the stages in cell division begins with the Gap 1 phase (E),

where the cell grows and prepares for DNA replication. This is followed by the Synthesis phase (C), during which DNA replication occurs. After DNA synthesis, the cell enters the Gap 2 phase (A), where it further prepares for mitosis. Karyokinesis (D), or nuclear division, follows, and finally, Cytokinesis (B) occurs, dividing the cytoplasm and forming two daughter cells. Understanding the order of these stages is essential for grasping the process of cell division and its regulation, which is vital in areas such as cancer research and developmental biology.

Conclusion: The correct answer is (4) E-C-A-D-B.

Quick Tip

Disruptions in the cell cycle can lead to diseases such as cancer, making it a critical area of study for medical research.

186. Given below are two statements: Statement I: Mitochondria and chloroplasts both are double-membrane-bound organelles. Statement II: The inner membrane of mitochondria is relatively less permeable, as compared to chloroplasts.

In the light of the above statements, choose the most appropriate answer from the options given below:

- (1) Both Statement I and Statement II are correct.
- (2) Both Statement I and Statement II are incorrect.
- (3) Statement I is correct but Statement II is incorrect.
- (4) Statement I is incorrect but Statement II is correct.

Correct Answer: (3) Statement I is correct but Statement II is incorrect.

Solution: Statement I is correct because both mitochondria and chloroplasts are double-membrane-bound organelles, which are essential for their respective roles in energy metabolism (mitochondria) and photosynthesis (chloroplasts).

Statement II is incorrect because the inner membrane of mitochondria is more impermeable

compared to the outer membrane, whereas in chloroplasts, both membranes are relatively permeable to ions and molecules.

Conclusion: The correct answer is (3) Statement I is correct but Statement II is incorrect.

Quick Tip

Both mitochondria and chloroplasts have double membranes, but their permeability characteristics are different.

187. Match List I with List II:

List-I	List-II
A. Mesozoic Era	I. Lower invertebrates
B. Proterozoic Era	II. Fish & Amphibia
C. Cenozoic Era	III. Birds & Reptiles
D. Paleozoic Era	IV. Mammals

Choose the correct answer from the options given below:

- (1) A-II, B-I, C-III, D-IV
- (2) A-III, B-I, C-II, D-IV
- (3) A-I, B-II, C-IV, D-III
- (4) A-III, B-I, C-IV, D-II

Correct Answer: (4) A-III, B-I, C-IV, D-II

Solution: A. Mesozoic Era is known for the rise of birds and reptiles, corresponding to III.

B. Proterozoic Era is marked by the evolution of lower invertebrates, corresponding to I.

C. Cenozoic Era is the age of mammals, corresponding to IV.

D. Paleozoic Era is characterized by the emergence of fish and amphibians, corresponding to II.

Conclusion: The correct match is (4) A-III, B-I, C-IV, D-II.

Quick Tip

Each geological era is characterized by the appearance and evolution of different life forms, with the Mesozoic Era famous for dinosaurs and reptiles.

188. Given below are two statements:

Statement I: Gause's competitive exclusion principle states that two closely related species competing for different resources cannot exist indefinitely.

Statement II: According to Gause's principle, during competition, the inferior will be eliminated. This may be true if resources are limiting.

In the light of the above statements, choose the correct answer from the options given below:

- (1) Both Statement I and Statement II are true.
- (2) Both Statement I and Statement II are false.
- (3) Statement I is true but Statement II is false.
- (4) Statement I is false but Statement II is true.

Correct Answer: (4) Statement I is false but Statement II is true.

Solution: Statement I is false because Gause's competitive exclusion principle actually states that two closely related species competing for the *same* resources cannot coexist indefinitely. Statement II is true as it correctly reflects that in competitive scenarios under limited resources, typically the inferior competitor will be eliminated.

Quick Tip

Understanding ecological principles like Gause's can help in conservation efforts by predicting the outcomes of species interactions.

189. Match List I with List II:

List I	List II
A. Unicellular glandular epithelium	I. Salivary glands
B. Compound epithelium	II. Pancreas
C. Multicellular glandular epithelium	III. Goblet cells of alimentary canal
D. Endocrine glandular epithelium	IV. Moist surface of buccal cavity

Choose the correct answer from the options given below:

- (1) A-II, B-I, C-III, D-IV
- (2) A-IV, B-III, C-I, D-II
- (3) A-III, B-IV, C-I, D-II
- (4) A-II, B-I, C-IV, D-III

Correct Answer: (3) A-III, B-IV, C-I, D-II

Solution: Unicellular glandular epithelium like goblet cells are found in the alimentary canal (A-III). Compound epithelium is found on moist surfaces like the buccal cavity (B-IV). Multicellular glandular epithelium like that in salivary glands produces various secretions (C-I). Endocrine glandular epithelium, such as in the pancreas, secretes hormones directly into the bloodstream (D-II).

Quick Tip

Understanding the structure and function of different types of epithelial tissue is crucial in anatomy and physiology for insights into how various body systems operate.

190. Match List I with List II related to the digestive system of a cockroach:

	List I		List II
A.	The structures used for storing of food	I.	Gizzard
B.	Ring of 6-8 blind tubules at junction of foregut and midgut.	II.	Gastric Caeca
C.	Ring of 100-150 yellow coloured thin filaments at junction of midgut and hindgut.	III.	Malpighian tubules
D.	The structures used for grinding the food.	IV.	Crop

Choose the correct answer from the options given below:

- (1) A-IV, B-II, C-III, D-I
- (2) A-I, B-II, C-III, D-IV
- (3) A-IV, B-III, C-II, D-I
- (4) A-III, B-II, C-IV, D-I

Correct Answer: (1) A-IV, B-II, C-III, D-I

Solution: A. The structures used for storing food: The crop is responsible for storing food in a cockroach, corresponding to IV.

B. Ring of 6-8 blind tubules at junction of foregut and midgut: These structures are gastric caeca, corresponding to II.

C. Ring of 100-150 yellow colored thin filaments at junction of midgut and hindgut: These are Malpighian tubules, corresponding to III.

D. The structures used for grinding the food: The gizzard is responsible for grinding food, corresponding to I.

Conclusion: The correct answer is (1) A-IV, B-II, C-III, D-I.

Quick Tip

In cockroaches, the crop stores food, the gastric caeca aid digestion, the Malpighian tubules excrete waste, and the gizzard grinds food.

191. Choose the correct statement given below regarding juxtamedullary nephron.

- (1) Juxtamedullary nephrons are located in the columns of Bertini.
- (2) Renal corpuscle of juxtamedullary nephron lies in the outer portion of the renal medulla.
- (3) Loop of Henle of juxtamedullary nephron runs deep into medulla.
- (4) Juxtamedullary nephrons outnumber the cortical nephrons.

Correct Answer: (3) Loop of Henle of juxtamedullary nephron runs deep into medulla.

Solution: Juxtamedullary nephrons are characterized by having a long loop of Henle that extends deep into the renal medulla, which plays a crucial role in the concentration of urine through the countercurrent mechanism.

The renal corpuscle of these nephrons is located near the boundary between the cortex and the medulla, but not in the outer portion of the renal medulla.

Juxtamedullary nephrons do not outnumber the cortical nephrons; actually, they are fewer in number compared to cortical nephrons.

Columns of Bertini refer to the regions in the kidney cortex, but juxtamedullary nephrons are not located here.

Conclusion: The correct answer is (3) Loop of Henle of juxtamedullary nephron runs deep into medulla.

Quick Tip

Juxtamedullary nephrons are essential for producing concentrated urine due to their long loops of Henle.

192. Match List I with List II:

List I	List II
A. RNA polymerase III	I. snRNPs
B. Termination of transcription	II. Promotor
C. Splicing of Exons	III. Rho factor
D. TATA box	IV. SnRNAs, tRNA

Choose the correct answer from the options given below:

- (1) A-II, B-IV, C-I, D-III
- (2) A-III, B-II, C-IV, D-I
- (3) A-III, B-IV, C-I, D-II

(4) A-IV, B-III, C-I, D-II

Correct Answer: (4) A-IV, B-III, C-I, D-II

Solution: RNA polymerase III transcribes genes encoding tRNAs and some snRNAs (A-IV). The termination of transcription in prokaryotes often involves the Rho factor (B-III). Splicing of exons is facilitated by snRNPs, which are part of the spliceosome complex (C-I). The TATA box is a core promoter element found in many genes (D-II).

Quick Tip

Familiarity with molecular biology's core concepts, like transcription and splicing, is vital for understanding genetic expression and regulation.

193. Given below are two statements: Statement I: The cerebral hemispheres are connected by a nerve tract known as the corpus callosum. Statement II: The brain stem consists of the medulla oblongata, pons, and cerebrum.

In light of the above statements, choose the most appropriate answer from the options given below:

- (1) Both Statement I and Statement II are correct.
- (2) Both Statement I and Statement II are incorrect.
- (3) Statement I is correct but Statement II is incorrect.
- (4) Statement I is incorrect but Statement II is correct.

Correct Answer: (3) Statement I is correct but Statement II is incorrect.

Solution: Statement I is correct because the corpus callosum is a large bundle of nerve fibers that connects the left and right cerebral hemispheres, allowing communication between them. Statement II is incorrect because the brainstem consists of the medulla oblongata, pons, and midbrain, not the cerebrum. The cerebrum is part of the forebrain, distinct from the brainstem.

Conclusion: The correct answer is (3) Statement I is correct but Statement II is incorrect.

Quick Tip

The brainstem is involved in basic life functions, while the cerebrum is responsible for higher brain functions.

194. Identify the correct option (A), (B), (C), (D) with respect to spermatogenesis.

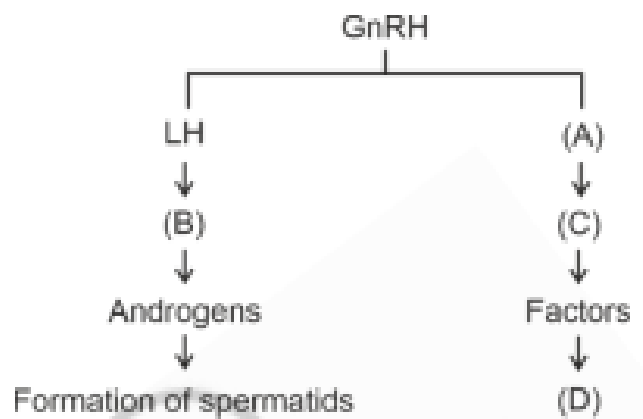

- (1) FSH, Leydig cells, Sertoli cells, spermiogenesis.
- (2) ICSH, Interstitial cells, Leydig cells, spermiogenesis.
- (3) FSH, Sertoli cells, Leydig cells, spermatogenesis.
- (4) ICSH, Leydig cells, Sertoli cells, spermatogenesis.

Correct Answer: (1) FSH, Leydig cells, Sertoli cells, spermiogenesis.

Solution: FSH stimulates Sertoli cells, which in turn support spermatogenesis. Leydig cells, stimulated by LH (also known as ICSH in males), produce testosterone, crucial for the final stages of spermatogenesis, known as spermiogenesis.

Quick Tip

Understanding hormonal regulation of spermatogenesis is important in fields like endocrinology and reproductive medicine.

195. As per ABO blood grouping system, the blood group of father is B+, mother is A+ and child is O+. Their respective genotype can be

- A. $I^B I^A / ii$
- B. $I^B I^B / I^A I^A$
- C. $I^A I^B / ii$
- D. $I^A I^B / I^A I^i$
- E. $ii / I^A I^B / I^A I^B$

- (1) A only
- (2) B only
- (3) C & B only
- (4) D & E only

Correct Answer: (1) A only

Solution: The father's blood group is B+, which means his genotype can be $I_B I_B$ (homozygous) or $I_B i$ (heterozygous).

The mother's blood group is A+, which means her genotype can be $I_A I_A$ or $I_A i$.

The child's blood group is O+, which must have the genotype ii as O blood type is recessive. For the child to inherit ii , both parents must contribute an i allele, meaning both parents must be heterozygous: $I_B i$ (father) and $I_A i$ (mother).

Quick Tip

For a child to have blood group O, both parents must carry the i allele.

196. Given below are two statements:

Statement I: Bone marrow is the main lymphoid organ where all blood cells including lymphocytes are produced.

Statement II: Both bone marrow and thymus provide microenvironments for the development and maturation of T-lymphocytes.

In the light of the above statements, choose the most appropriate answer from the options given below:

- (1) Both Statement I and Statement II are correct.
- (2) Both Statement I and Statement II are incorrect.
- (3) Statement I is correct but Statement II is incorrect.
- (4) Statement I is incorrect but Statement II is correct.

Correct Answer: (1) Both Statement I and Statement II are correct.

Solution: - Statement I is accurate because bone marrow is the primary site where all types of blood cells, including lymphocytes, are produced through hematopoiesis. - Statement II is also correct since both bone marrow and thymus play essential roles in T-lymphocyte development. Bone marrow produces the precursor cells, while the thymus is responsible for their maturation into functional T-cells.

Conclusion: Both statements are true, and thus, the correct answer is (1).

Quick Tip

Bone marrow and thymus are vital to the immune system, with the former producing immune cells and the latter maturing T-cells.

197. Regarding the catalytic cycle of an enzyme action, select the correct sequential steps:

- A. Substrate-enzyme complex formation.
- B. Free enzyme ready to bind with another substrate.

- C. Release of products.
- D. Chemical bonds of the substrate broken.
- E. Substrate binding to the active site.

Choose the correct answer from the options given below:

- (1) E, A, D, C, B
- (2) A, E, B, D, C
- (3) B, A, C, D, E
- (4) E, D, C, B, A

Correct Answer: (1) E, A, D, C, B

Solution: The correct order for the catalytic cycle of enzyme action is:

- E. Substrate binding to the active site: The enzyme's active site binds with the substrate, which initiates the catalytic process.
- A. Substrate-enzyme complex formation: The enzyme and substrate form a complex, facilitating the chemical reaction.
- D. Chemical bonds of the substrate broken: The enzyme catalyzes the breaking of bonds in the substrate, leading to the formation of products.
- C. Release of products: The newly formed products are released from the enzyme's active site.
- B. Free enzyme ready to bind with another substrate: The enzyme is now free and available to catalyze another reaction.

Conclusion: The correct answer is (1) E, A, D, C, B.

Quick Tip

Enzyme catalysis involves the enzyme-substrate complex formation, product release, and the enzyme's ability to catalyze further reactions.

198. Match List I with List II:

List-I	List-II
A. P wave	I. Heart muscles are electrically silent.
B. QRS complex	II. Depolarization of ventricles.
C. T wave	III. Depolarization of atria.
D. T-P gap	IV. Repolarization of ventricles.

Choose the correct answer from the options given below:

- (1) A-I, B-III, C-IV, D-II
- (2) A-III, B-II, C-IV, D-I
- (3) A-II, B-III, C-I, D-IV
- (4) A-IV, B-II, C-I, D-III

Correct Answer: (2) A-III, B-II, C-IV, D-I

Solution: - A. P wave corresponds to the depolarization of the atria, which is listed as III.

- B. QRS complex represents the depolarization of the ventricles, linked to II.

- C. T wave corresponds to the repolarization of the ventricles, represented by IV.

- D. T-P gap is the period when the heart muscles are electrically silent, represented by I.

Conclusion: The correct match is (2) A-III, B-II, C-IV, D-I.

Quick Tip

The ECG (electrocardiogram) records the electrical activity of the heart, showing the processes of atrial and ventricular depolarization and repolarization.

199. Match List I with List II:

List-I	List-II
A. Exophthalmic goiter	I. Excess secretion of cortisol, moon face & hyperglycemia.
B. Acromegaly	II. Hypo-secretion of thyroid hormone and stunted growth.
C. Cushing's syndrome	III. Hyper secretion of thyroid hormone & protruding eyeballs.
D. Cretinism	IV. Excessive secretion of growth hormone.

Choose the correct answer from the options given below:

- (1) A-I, B-III, C-II, D-IV
- (2) A-IV, B-II, C-I, D-III

(3) A-III, B-IV, C-II, D-I

(4) A-III, B-IV, C-I, D-II

Correct Answer: (4) A-III, B-IV, C-I, D-II

Solution: - A. Exophthalmic goiter is related to hypersecretion of thyroid hormones, causing protruding eyeballs, corresponding to III.

- B. Acromegaly results from excessive growth hormone secretion, corresponding to IV.

- C. Cushing's syndrome is caused by excess cortisol secretion, leading to symptoms like moon face and hyperglycemia, corresponding to I.

- D. Cretinism results from hypothyroidism in childhood, leading to stunted growth, corresponding to II.

Conclusion: The correct answer is (4) A-III, B-IV, C-I, D-II.

Quick Tip

Exophthalmic goiter is another term for Graves' disease, characterized by hyperthyroidism and protruding eyeballs.

200. The following are the statements about non-chordates:

A. Pharynx is perforated by gill slits.

B. Notochord is absent.

C. Central nervous system is dorsal.

D. Heart is dorsal if present.

E. Post-anal tail is absent.

Choose the most appropriate answer from the options given below:

(1) A & C only

(2) A, B & D only

(3) B, D & E only

(4) B, C & D only

Correct Answer: (3) B, D & E only

Solution: - Statement A is true for chordates but not for all non-chordates.

- Statement B is correct for non-chordates as they lack a notochord.
- Statement D is true for many non-chordates, as their heart is dorsal, such as in arthropods.
- Statement E is true for some non-chordates that lack a post-anal tail, like arthropods.
- Statement C is incorrect because the central nervous system of non-chordates is not always dorsal.

Conclusion: The correct answer is (3) B, D & E only.

Quick Tip

Non-chordates typically lack a notochord, dorsal nervous system, and a post-anal tail, distinguishing them from chordates.
