

# NEET 2024 Question Paper Set S6

Time Allowed :3 Hours 20 mins	Maximum Marks :720	Total Questions :200
-------------------------------	--------------------	----------------------

## General Instructions

Read the following instructions very carefully and strictly follow them:

1. The test is of 3 hours 20 minutes duration.
2. The question paper consists of 200 questions out of which 180 MCQs must be answered. The maximum marks are 720.
3. There are four parts in the question paper consisting of Biology, Physics, Chemistry and Mathematics.
4. Each subject will be divided into two sections, A and B which will have 35 and 15 questions respectively. Candidates will have to answer only 10 questions in Section B.
5. 4 marks are awarded for each correct answer and 1 mark is deducted for each wrong answer

## PHYSICS

### SECTION-A

#### 1. Match List I with List II.

	List I (Spectral Lines of Hydrogen for transitions from)		List II (Wavelengths (nm))
A.	$n_2 = 3$ to $n_1 = 2$	I.	410.2
B.	$n_2 = 4$ to $n_1 = 2$	II.	434.1
C.	$n_2 = 5$ to $n_1 = 2$	III.	656.3
D.	$n_2 = 6$ to $n_1 = 2$	IV.	486.1

Choose the correct answer from the options given below:

- (A) A-I, B-II, C-III, D-IV
- (B) A-II, B-I, C-IV, D-III
- (C) A-III, B-IV, C-II, D-I
- (D) A-IV, B-III, C-I, D-II

**2. Match List I with List II.**

List I(Material)	List II(Susceptibility $\chi$ )
(A) Diamagnetic	(I) $\chi = 0$
(B) Ferromagnetic	(II) $0 > \chi \geq -1$
(C) Paramagnetic	(III) $\chi \gg 1$
(D) Non-magnetic	(IV) $0 < \chi < \epsilon$ (a small positive number)

Choose the correct answer from the options given below:

- (A) A-IV, B-III, C-II, D-I
- (B) A-II, B-III, C-IV, D-I
- (C) A-II, B-I, C-III, D-IV
- (D) A-III, B-II, C-I, D-IV

**3. In a uniform magnetic field of  $0.049 T$ , a magnetic needle performs 20 complete oscillations in 5 seconds. The moment of inertia of the needle is  $9.8 \times 10^{-6} kg \cdot m^2$ . If the magnitude of the magnetic moment of the needle is  $x \times 10^{-5} Am^2$ , then the value of  $x$  is:**

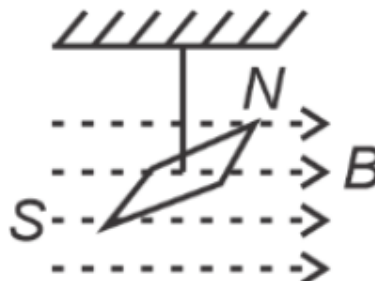

- (A)  $1280\pi^2$
- (B)  $5\pi^2$

(C)  $128\pi^2$

(D)  $50\pi^2$

**4. An unpolarised light beam strikes a glass surface at Brewster's angle. Then:**

(A) The reflected light will be completely polarised but the refracted light will be partially polarised.

(B) The reflected light will be partially polarised.

(C) The refracted light will be completely polarised.

(D) Both the reflected and refracted light will be completely polarised.

---

**5. Consider the following statements A and B and identify the correct answer:**

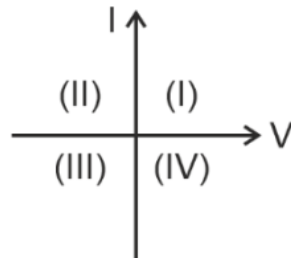

(A) For a solar cell, the I-V characteristics lie in the IV quadrant of the given graph.

(B) In a reverse biased *pn* junction diode, the current measured in ( $\mu A$ ) is due to majority charge carriers.

(A) Both A and B are incorrect.

(B) A is correct but B is incorrect.

(C) A is incorrect but B is correct.

(D) Both A and B are correct.

---

**6. A light ray enters through a right-angled prism at point *P* with the angle of incidence  $30^\circ$  as shown in the figure. It travels through the prism parallel to its base *BC* and emerges along the face *AC*. The refractive index of the prism is:**

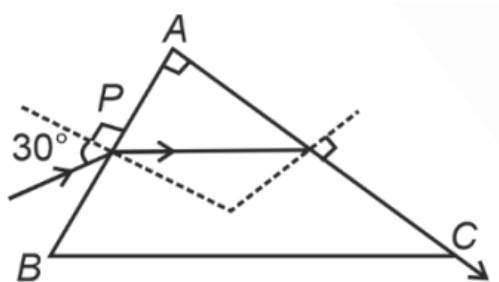

- (A)  $\frac{\sqrt{3}}{2}$
- (B)  $\frac{\sqrt{5}}{4}$
- (C)  $\frac{\sqrt{5}}{2}$
- (D)  $\frac{\sqrt{3}}{4}$

**7. A particle moving with uniform speed in a circular path maintains:**

- (A) Varying velocity and varying acceleration
- (B) Constant velocity
- (C) Constant acceleration
- (D) Constant velocity but varying acceleration

**8. The graph which shows the variation of  $\frac{1}{\lambda^2}$  and its kinetic energy,  $E$  (where  $\lambda$  is de Broglie wavelength of a free particle):**

- (A)
- (B)
- (C)

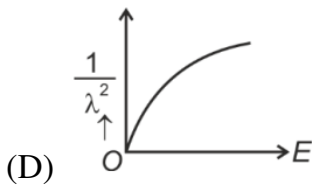

9. A wire of length  $l$  and resistance  $100\Omega$  is divided into 10 equal parts. The first 5 parts are connected in series while the next 5 parts are connected in parallel. The two combinations are again connected in series. The resistance of this final combination is:

- (A)  $60\Omega$
- (B)  $26\Omega$
- (C)  $52\Omega$
- (D)  $55\Omega$

10. The moment of inertia of a thin rod about an axis passing through its midpoint and perpendicular to the rod is  $2400\text{ cm}^2$ . The length of the 400 g rod is nearly:

- (A) 72.0 cm
- (B) 8.5 cm
- (C) 17.5 cm
- (D) 20.7 cm

11. The output (Y) of the given logic gate is similar to the output of an/a

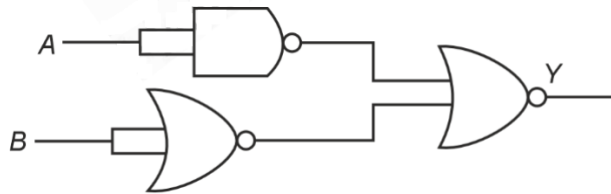

- (A) AND gate
- (B) NAND gate
- (C) NOR gate

(D) OR gate

---

**12. In a vernier calipers,  $(N + 1)$  divisions of the vernier scale coincide with  $N$  divisions of the main scale. If 1 MSD represents 0.1 mm, the vernier constant (in cm) is:**

- (A)  $10(N + 1)$
  - (B)  $\frac{1}{10N}$
  - (C)  $\frac{1}{100(N+1)}$
  - (D)  $100N$
- 

**13. At any instant of time  $t$ , the displacement of any particle is given by  $2t - 1$  (SI unit) under the influence of force of 5 N. The value of instantaneous power is (in SI unit):**

- (A) 6
  - (B) 10
  - (C) 5
  - (D) 7
- 

**14. A thin spherical shell is charged by some source. The potential difference between the two points  $C$  and  $P$  (in V) shown in the figure is:**

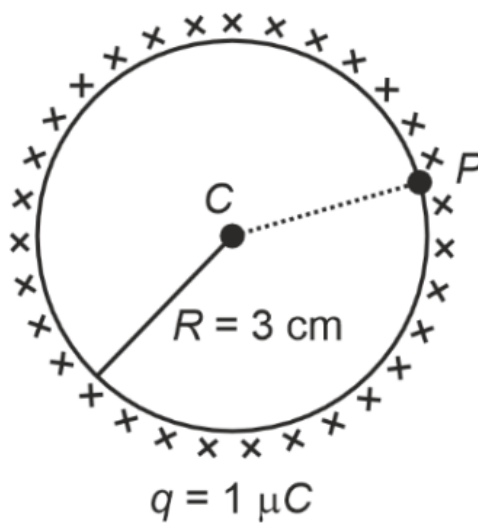

(Take  $\frac{1}{4\pi\epsilon_0} = 9 \times 10^9$  SI units)

- (A) Zero
  - (B)  $3 \times 10^5$
  - (C)  $1 \times 10^5$
  - (D)  $0.5 \times 10^5$
- 

**15. A thin flat circular disc of radius 4.5 cm is placed gently over the surface of water. If surface tension of water is  $0.07 \text{ N m}^{-1}$ , then the excess force required to take it away from the surface is:**

- (A) 99 N
  - (B) 19.8 mN
  - (C) 198 N
  - (D) 1.98 mN
- 

**16. A logic circuit provides the output  $Y$  as per the following truth table:**

$A$	$B$	$Y$
0	0	1
0	1	0
1	0	0
1	1	0

- (A)  $B$
  - (B)  $A.B + \bar{A}$
  - (C)  $A.\bar{B} + \bar{A}$
  - (D)  $\bar{B}$
- 

**17. Given below are two statements: one is labelled as Assertion A and the other is labelled as Reason R.**

**Assertion A:** The potential ( $V$ ) at any axial point, at 2 m distance ( $r$ ) from the centre of the dipole of dipole moment vector  $P$  of magnitude,  $4 \times 10^{-6}$  C m, is  $\pm 9 \times 10^3$  V.

(Take  $\frac{1}{4\pi\epsilon_0} = 9 \times 10^9$  SI units)

**Reason R:** The potential at an axial point of a dipole is given by:

$$V = \pm \frac{2P}{4\pi\epsilon_0 r^2}$$

where  $r$  is the distance of any axial point, situated at 2 m from the centre of the dipole.

In the light of the above statements, choose the **correct answer** from the options given below:

- (A) A is false but R is true.
- (B) Both A and R are true and R is the correct explanation of A.
- (C) Both A and R are true and R is NOT the correct explanation of A.
- (D) A is true but R is false.

---

**18. The terminal voltage of the battery, whose emf is 10 V and internal resistance 1  $\Omega$ , when connected through an external resistance of 4  $\Omega$  as shown in the figure is:**

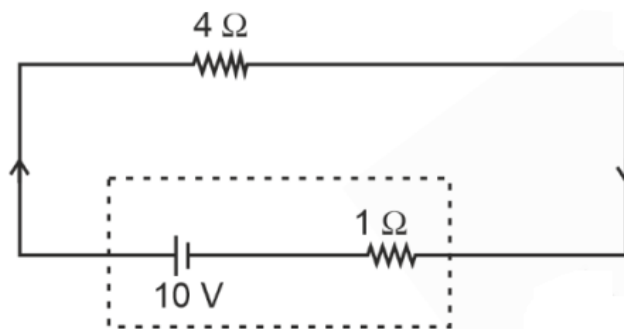

- (A) 10 V
- (B) 4 V
- (C) 6 V
- (D) 8 V

19. In the above diagram, a strong bar magnet is moving towards solenoid-2 from solenoid-1. The direction of induced current in solenoid-1 and that in solenoid-2, respectively, are through the directions:

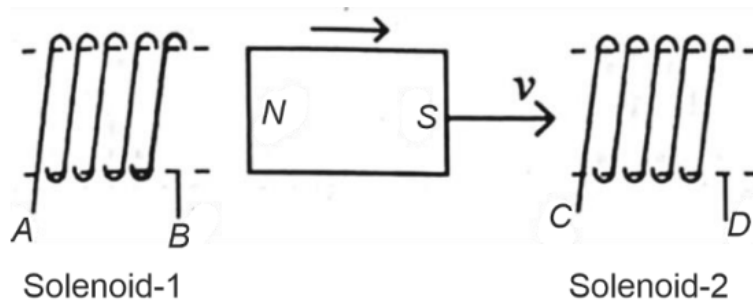

- (A) BA and DC
- (B) AB and DC
- (C) BA and CD
- (D) AB and CD

20. In an ideal transformer, the turns ratio is  $\frac{N_p}{N_s} = \frac{1}{2}$ . The ratio  $V_S : V_P$  is equal to (the symbols carry their usual meaning):

- (A) 1 : 4
- (B) 1 : 2
- (C) 2 : 1
- (D) 1 : 1

21. A tightly wound 100 turns coil of radius 10 cm carries a current of 7 A. The magnitude of the magnetic field at the centre of the coil is (Take permeability of free space as  $4\pi \times 10^{-7}$  SI units):

- (A) 44 T
- (B) 44 mT
- (C) 4.4 T
- (D) 4.4 mT

---

**22. Given below are two statements:**

**Statement I:** Atoms are electrically neutral as they contain equal number of positive and negative charges.

**Statement II:** Atoms of each element are stable and emit their characteristic spectrum.

In the light of the above statements, choose the **most appropriate answer** from the options given below:

- (A) Statement I is incorrect but Statement II is correct.
- (B) Both Statement I and Statement II are correct.
- (C) Both Statement I and Statement II are incorrect.
- (D) Statement I is correct but Statement II is incorrect.

---

**23. The quantities which have the same dimensions as those of solid angle are:**

- (A) angular speed and stress
- (B) strain and angle
- (C) stress and angle
- (D) strain and arc

---

**24. If  $c$  is the velocity of light in free space, the correct statements about photon among the following are:**

- (A) The energy of a photon is  $E = h\nu$ .
- (B) The velocity of a photon is  $c$ .
- (C) The momentum of a photon,  $p = \frac{h\nu}{c}$ .
- (D) In a photon-electron collision, both total energy and total momentum are conserved.
- (E) Photon possesses positive charge.

Choose the correct answer from the options given below:

- (A) A, B, D and E only

- (B) A and B only
  - (C) A, B, C and D only
  - (D) A, C and D only
- 

25. A bob is whirled in a horizontal plane by means of a string with an initial speed of  $\omega$  rpm. The tension in the string is  $T$ . If speed becomes  $2\omega$  while keeping the same radius, the tension in the string becomes:

- (A)  $\sqrt{2}T$
  - (B)  $T$
  - (C)  $4T$
  - (D)  $\frac{T}{4}$
- 

26. If  $x = 5 \sin\left(\pi t + \frac{\pi}{3}\right)$  m represents the motion of a particle executing simple harmonic motion, the amplitude and time period of motion, respectively, are:

- (A) 5 m, 1 s
  - (B) 5 cm, 2 s
  - (C) 5 m, 2 s
  - (D) 5 cm, 1 s
- 

27. A thermodynamic system is taken through the cycle  $abcd$ . The work done by the gas along the path  $bc$  is:

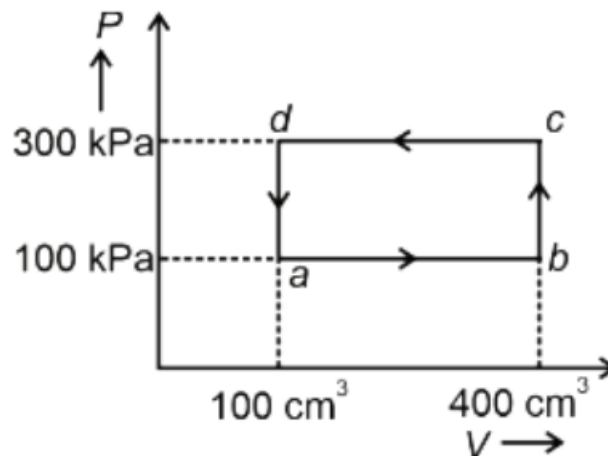

- (A)  $-60 \text{ J}$
- (B) Zero
- (C)  $30 \text{ J}$
- (D)  $-90 \text{ J}$

**28. In the nuclear emission stated below, the mass number and atomic number of the product  $Q$  respectively, are:**

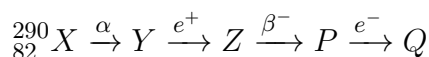

- (A) 286, 81
- (B) 280, 81
- (C) 286, 80
- (D) 288, 82

**29. Two bodies  $A$  and  $B$  of same mass undergo completely inelastic one-dimensional collision. The body  $A$  moves with velocity  $v_1$  while body  $B$  is at rest before collision. The velocity of the system after collision is  $v_2$ . The ratio  $v_1 : v_2$  is:**

- (A) 1 : 4
- (B) 1 : 2
- (C) 2 : 1
- (D) 4 : 1

**30. In the following circuit, the equivalent capacitance between terminal  $A$  and terminal  $B$  is:**

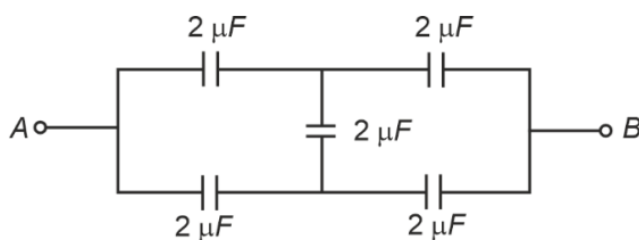

- (A)  $4\mu F$
- (B)  $2\mu F$
- (C)  $1\mu F$
- (D)  $0.5\mu F$

---

**31. A horizontal force 10 N is applied to a block A as shown in the figure. The mass of blocks A and B are 2 kg and 3 kg respectively. The blocks slide over a frictionless surface. The force exerted by block A on block B is:**

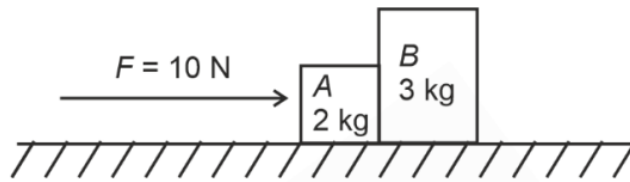

- (A) 10 N
- (B) 0
- (C) 4 N
- (D) 6 N

---

**32. A wheel of a bullock cart is rolling on a level road as shown in the figure below. If its linear speed is  $v$  in the direction shown, which one of the following options is correct (P and Q are the highest and lowest points on the wheel, respectively)?**

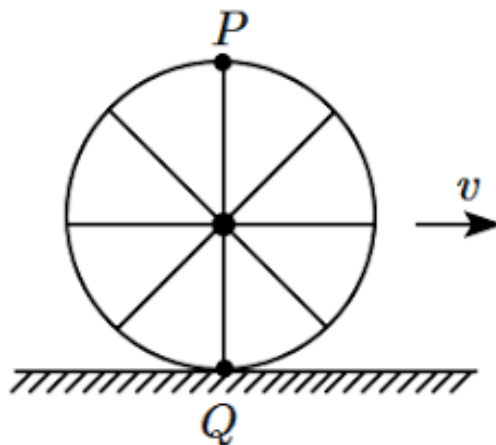

- (A) Point  $P$  has zero speed
  - (B) Point  $P$  moves slower than point  $Q$
  - (C) Point  $P$  moves faster than point  $Q$
  - (D) Both points  $P$  and  $Q$  move with equal speed
- 

**33. The mass of a planet is  $\frac{1}{10}$ th that of the earth and its diameter is half that of the earth. The acceleration due to gravity on that planet is:**

- (A)  $3.92 \text{ m s}^{-2}$
  - (B)  $19.6 \text{ m s}^{-2}$
  - (C)  $9.8 \text{ m s}^{-2}$
  - (D)  $4.9 \text{ m s}^{-2}$
- 

**34. The maximum elongation of a steel wire of 1 m length if the elastic limit of steel and its Young's modulus, respectively, are  $8 \times 10^8 \text{ N m}^{-2}$  and  $2 \times 10^{11} \text{ N m}^{-2}$ , is:**

- (A) 8 mm
  - (B) 4 mm
  - (C) 0.4 mm
  - (D) 40 mm
- 

**35. If the monochromatic source in Young's double slit experiment is replaced by white light, then:**

- (A) All bright fringes will be of equal width
  - (B) Interference pattern will disappear
  - (C) There will be a central dark fringe surrounded by a few coloured fringes
  - (D) There will be a central bright white fringe surrounded by a few coloured fringes
-

## SECTION-B

**36. A small telescope has an objective of focal length 140 cm and an eye piece of focal length 5.0 cm. The magnifying power of telescope for viewing a distant object is:**

- (A) 32
  - (B) 34
  - (C) 28
  - (D) 17
- 

**37. If the plates of a parallel plate capacitor connected to a battery are moved close to each other, then:**

- (A) The charge stored in it, increases.
- (B) The energy stored in it, decreases.
- (C) Its capacitance increases.
- (D) The ratio of charge to its potential remains the same.
- (E) The product of charge and voltage increases.

Choose the most appropriate answer from the options given below:

- (A) A, B and C only
  - (B) A, B and E only
  - (C) A, C and E only
  - (D) B, D and E only
- 

**38. A  $10 \mu\text{F}$  capacitor is connected to a 210 V, 50 Hz source as shown in figure. The peak current in the circuit is nearly ( $\pi = 3.14$ ):**

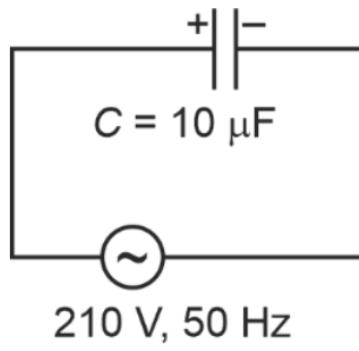

- (A) 0.35 A
- (B) 0.58 A
- (C) 0.93 A
- (D) 1.20 A

**39. Choose the correct circuit which can achieve the bridge balance.**

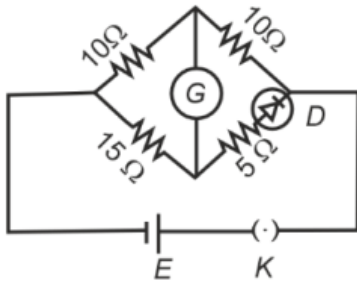

(A)

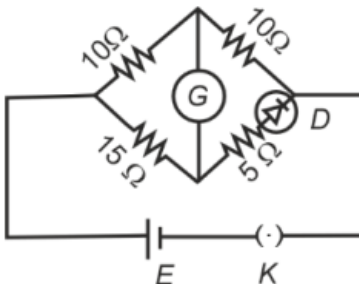

(B)

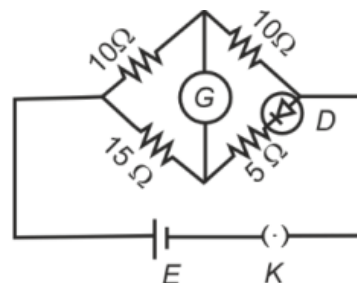

(C)

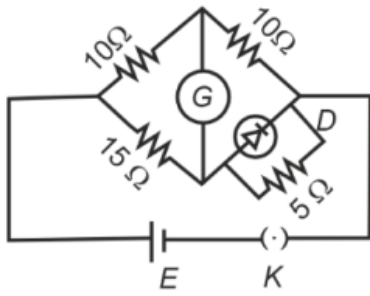

(D)

40. Two heaters *A* and *B* have power ratings of 1 kW and 2 kW, respectively. Those two are first connected in series and then in parallel to a fixed power source. The ratio of power outputs for these two cases is:

- (A) 2 : 3
- (B) 1 : 1
- (C) 2 : 9
- (D) 1 : 2

41. The velocity (*v*– time (*t*) plot of the motion of a body is shown below:

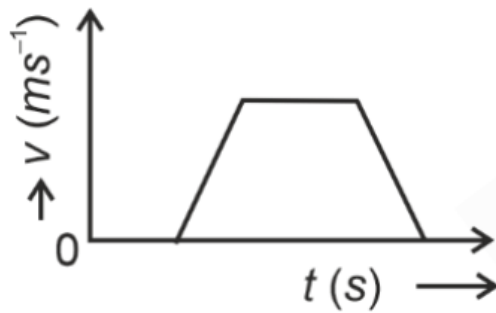

The acceleration (*a* – time (*t*) graph that best suits this motion is:

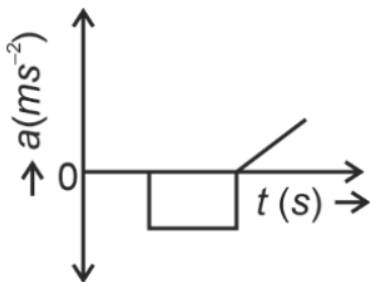

(A)

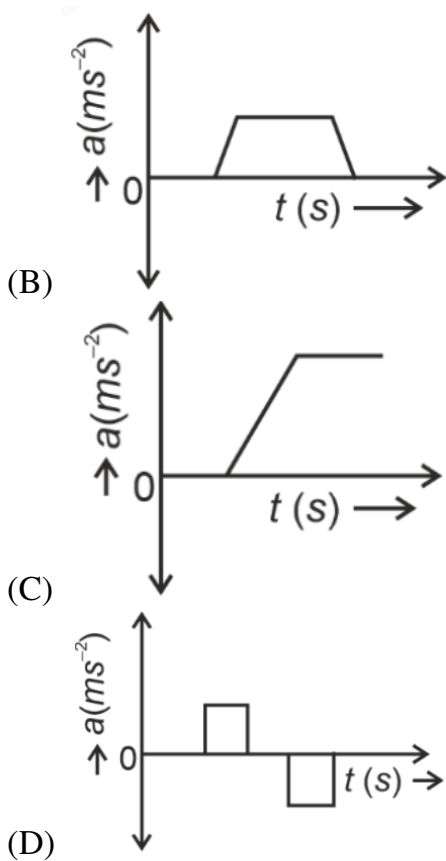

42. If the mass of the bob in a simple pendulum is increased to thrice its original mass and its length is made half its original length, then the new time period of oscillation is  $\frac{x}{2}$  times its original time period. Then the value of  $x$  is:

- (A) 4
- (B)  $\sqrt{3}$
- (C)  $\sqrt{2}$
- (D)  $2\sqrt{3}$

43. A metallic bar of Young's modulus,  $0.5 \times 10^{11} \text{ N m}^{-2}$  and coefficient of linear thermal expansion  $10^{-5} \text{ }^\circ\text{C}^{-1}$ , length 1 m and area of cross-section  $10^{-3} \text{ m}^2$  is heated from  $0^\circ\text{C}$  to  $100^\circ\text{C}$  without expansion or bending. The compressive force developed in it is:

- (A)  $2 \times 10^3 \text{ N}$
- (B)  $5 \times 10^3 \text{ N}$

- (C)  $50 \times 10^3$  N  
(D)  $100 \times 10^3$  N
- 

**44. A sheet is placed on a horizontal surface in front of a strong magnetic pole. A force is needed to:**

- (A) Hold the sheet there if it is magnetic.  
(B) Hold the sheet there if it is non-magnetic.  
(C) Move the sheet away from the pole with uniform velocity if it is conducting.  
(D) Move the sheet away from the pole with uniform velocity if it is both, non-conducting and non-polar.

Choose the correct statement(s) from the options given below:

- (A) C only  
(B) B and D only  
(C) A and C only  
(D) A, C and D only
- 

**45. The property which is not of an electromagnetic wave travelling in free space is:**

- (A) They originate from charges moving with uniform speed  
(B) They are transverse in nature  
(C) The energy density in electric field is equal to energy density in magnetic field  
(D) They travel with a speed equal to  $\frac{1}{\sqrt{\mu_0 \epsilon_0}}$
- 

**46. A parallel plate capacitor is charged by connecting it to a battery through a resistor. If  $I$  is the current in the circuit, then in the gap between the plates:**

- (A) Displacement current of magnitude greater than  $I$  flows but can be in any direction  
(B) There is no current  
(C) Displacement current of magnitude equal to  $I$  flows in the same direction as  $I$

(D) Displacement current of magnitude equal to  $I$  flows in a direction opposite to that of  $I$

---

**47. An iron bar of length  $L$  has magnetic moment  $M$ . It is bent at the middle of its length such that the two arms make an angle  $60^\circ$  with each other. The magnetic moment of this new magnet is:**

- (A)  $\frac{M}{\sqrt{3}}$
  - (B)  $M$
  - (C)  $\frac{M}{2}$
  - (D)  $2M$
- 

**48. The minimum energy required to launch a satellite of mass  $m$  from the surface of earth of mass  $M$  and radius  $R$  in a circular orbit at an altitude of  $2R$  from the surface of the earth is:**

- (A)  $\frac{GmM}{3R}$
  - (B)  $\frac{5GmM}{6R}$
  - (C)  $\frac{2GmM}{3R}$
  - (D)  $\frac{GmM}{2R}$
- 

**49. The following graph represents the  $T - V$  curves of an ideal gas (where  $T$  is the temperature and  $V$  the volume) at three pressures  $P_1, P_2$  and  $P_3$  compared with those of Charles's law represented as dotted lines.**

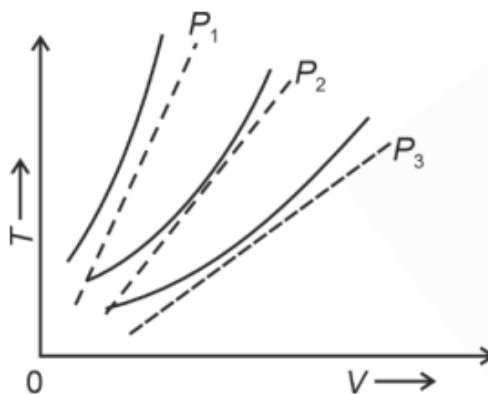

- (A)  $P_1 > P_2 > P_3$   
(B)  $P_3 > P_2 > P_1$   
(C)  $P_3 > P_1 > P_2$   
(D)  $P_2 > P_1 > P_3$
- 

**50. A force defined by  $F = \alpha t + \beta t$  acts on a particle at a given time  $t$ . The factor which is dimensionless, if  $\alpha$  and  $\beta$  are constants, is:**

- (A)  $\frac{\alpha\beta}{t}$   
(B)  $\frac{\beta t}{\alpha}$   
(C)  $\frac{\alpha t}{\beta}$   
(D)  $\alpha\beta t$
- 

## CHEMISTRY

### SECTION-A

**51. Given below are two statements:**

**Statement I:** Aniline does not undergo Friedel-Crafts alkylation reaction.

**Statement II:** Aniline cannot be prepared through Gabriel synthesis.

In the light of the above statements, choose the correct answer from the options given below:

- (1) Statement I is incorrect but Statement II is true  
(2) Both Statement I and Statement II are true  
(3) Both Statement I and Statement II are false  
(4) Statement I is correct but Statement II is false
- 

**52. Match List I with List II.**

List I (Compound)	List II (Shape/geometry)
(A) NH <sub>3</sub>	(I) Trigonal Pyramidal
(B) BrF <sub>5</sub>	(II) Square Planar
(C) XeF <sub>4</sub>	(III) Octahedral
(D) SF <sub>6</sub>	(IV) Square Pyramidal

Choose the correct answer from the options given below:

- (1) A-II, B-III, C-IV, D-I
- (2) A-I, B-IV, C-II, D-III
- (3) A-II, B-IV, C-III, D-I
- (4) A-III, B-IV, C-I, D-II

**53. Match List I with List II.**

List I (Molecule)	List II (Number and types of bonds between two carbon atoms)
(A) Ethane	(I) One $\sigma$ -bond and two $\pi$ -bonds
(B) Ethene	(II) Two $\pi$ -bonds
(C) Carbon molecule, C <sub>2</sub>	(III) One $\sigma$ -bond
(D) Ethyne	(IV) One $\sigma$ -bond and one $\pi$ -bond

Choose the correct answer from the options given below:

- (1) A-III, B-IV, C-I, D-II
- (2) A-I, B-IV, C-II, D-III
- (3) A-IV, B-III, C-II, D-I
- (4) A-III, B-IV, C-II, D-I

**54. For the reaction  $2A \rightleftharpoons B + C$ ,  $K_C = 4 \times 10^{-3}$ . At a given time, the composition of reaction mixture is  $[A] = [B] = [C] = 2 \times 10^{-3}M$ .**

Then, which of the following is correct?

- (1) Reaction has gone to completion in forward direction.
  - (2) Reaction is at equilibrium.
  - (3) Reaction has a tendency to go in forward direction.
  - (4) Reaction has a tendency to go in backward direction.
- 

**55. Match List I with List II.**

<b>List I (Process)</b>	<b>List II (Conditions)</b>
(A) Isothermal process	(I) No heat exchange
(B) Isochoric process	(II) Carried out at constant temperature
(C) Isobaric process	(III) Carried out at constant volume
(D) Adiabatic process	(IV) Carried out at constant pressure

Choose the correct answer from the options given below:

- (1) A-II, B-III, C-IV, D-I
  - (2) A-IV, B-III, C-II, D-I
  - (3) A-IV, B-II, C-III, D-I
  - (4) A-I, B-II, C-III, D-IV
- 

**56. Match List I with List II.**

<b>List I (Quantum Number)</b>	<b>List II (Information provided)</b>
(A) $m_l$	(I) Shape of orbital
(B) $m_s$	(II) Size of orbital
(C) $l$	(III) Orientation of orbital
(D) $n$	(IV) Orientation of spin of electron

Choose the correct answer from the options given below:

- (1) A-II, B-I, C-IV, D-III

- (2) A-I, B-II, C-III, D-IV
  - (3) A-III, B-IV, C-I, D-II
  - (4) A-III, B-IV, C-II, D-I
- 

**57. Arrange the following elements in increasing order of first ionization enthalpy:  
Li, Be, B, C, N**

Choose the correct answer from the options given below:

- (1)  $\text{Li} < \text{Be} < \text{N} < \text{B} < \text{C}$
  - (2)  $\text{Li} < \text{Be} < \text{C} < \text{N} < \text{B}$
  - (3)  $\text{Li} < \text{B} < \text{Be} < \text{C} < \text{N}$
  - (4)  $\text{Li} < \text{Be} < \text{C} < \text{B} < \text{N}$
- 

**58. Among Group 16 elements, which one does NOT show  $-2$  oxidation state?**

- (1) Po
  - (2) O
  - (3) Se
  - (4) Te
- 

**59. In which of the following equilibria,  $K_p$  and  $K_c$  are NOT equal?**

- (1)  $2\text{BrCl}_{(g)} \rightleftharpoons \text{Br}_{2(g)} + \text{Cl}_{2(g)}$
  - (2)  $\text{PCl}_{5(g)} \rightleftharpoons \text{PCl}_{3(g)} + \text{Cl}_{2(g)}$
  - (3)  $\text{H}_{2(g)} + \text{I}_{2(g)} \rightleftharpoons 2\text{HI}_{(g)}$
  - (4)  $\text{CO}_{(g)} + \text{H}_2\text{O}_{(g)} \rightleftharpoons \text{CO}_{2(g)} + \text{H}_2(g)$
- 

**60. The reagents with which glucose does NOT react to give the corresponding tests/products are:**

- (A) Tollen's reagent
- (B) Schiff's reagent

- (C) HCN  
(D)  $NH_2OH$   
(E)  $NaHSO_3$

Choose the correct options from the given below:

- (1) E and D  
(2) B and C  
(3) A and D  
(4) B and E

---

**61. Identify the correct reagents that would bring about the following transformation.**

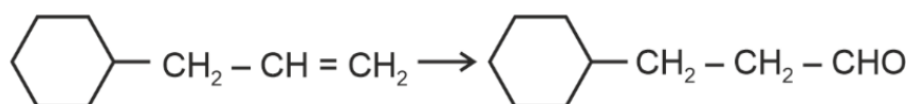

- (1) (i)  $H_2O/H^+$   
(ii) PCC  
(2) (i)  $H_2O/H^+$   
(ii)  $CrO_3$   
(3) (i)  $BH_3$   
(ii)  $H_2O_2/OH^-$   
(iii) PCC  
(4) (i)  $BH_3$   
(ii)  $H_2O_2/OH^-$   
(iii) alk.  $KMnO_4$   
(iv)  $H_3O^+$

---

**62. The  $E^\circ$  value for the  $Mn^{3+}/Mn^{2+}$  couple is more positive than that of  $Cr^{3+}/Cr^{2+}$  or  $Fe^{3+}/Fe^{2+}$  due to change of:**

- (1)  $d^3$  to  $d^5$  configuration  
(2)  $d^5$  to  $d^4$  configuration

(3)  $d^5$  to  $d^2$  configuration

(4)  $d^4$  to  $d^5$  configuration

---

**63. Given below are two statements:**

**Statement I:** Both  $[\text{Co}(\text{NH}_3)_6]^{3+}$  and  $[\text{CoF}_6]^{3-}$  complexes are octahedral but differ in their magnetic behavior.

**Statement II:**  $[\text{Co}(\text{NH}_3)_6]^{3+}$  is diamagnetic whereas  $[\text{CoF}_6]^{3-}$  is paramagnetic.

Choose the correct answer from the options given below:

(1) Statement I is false but Statement II is true

(2) Both Statement I and Statement II are true

(3) Both Statement I and Statement II are false

(4) Statement I is true but Statement II is false

---

**64. Fehling's solution 'A' is:**

(1) Aqueous sodium citrate

(2) Aqueous copper sulphate

(3) Alkaline copper sulphate

(4) Alkaline solution of sodium potassium tartrate (Rochelle's salt)

---

**65. In which of the following processes entropy increases?**

(A) A liquid evaporates to vapor.

(B) Temperature of a crystalline solid is lowered from 130 K to 0 K.

(C)  $2\text{NaHCO}_3(s) \rightarrow \text{Na}_2\text{CO}_3(s) + \text{CO}_2(g) + \text{H}_2\text{O}(g)$

(D)  $\text{Cl}_2(g) \rightarrow 2\text{Cl}(g)$

Choose the correct answer from the options given below:

(1) C and D

(2) A and C

(3) A and B

(4) A, C and D

---

66. The energy of an electron in the ground state ( $n = 1$ ) for  $\text{He}^+$  ion is  $-x$  J. Then, for an electron in  $n = 2$  state for  $\text{Be}^{3+}$  ion, the energy in J is:

- (1)  $-\frac{4}{9}x$   
(2)  $-x$   
(3)  $-\frac{x}{9}$   
(4)  $-4x$

---

67. Match List I with List II.

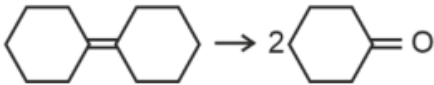
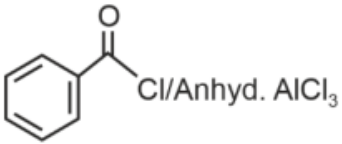
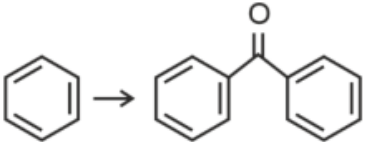
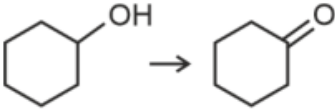
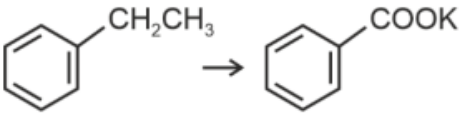
List I (Reaction)	List II (Reagents/Condition)
A. 	I. 
B. 	II. $\text{CrO}_3$
C. 	III. $\text{KMnO}_4/\text{KOH}, \Delta$
D. 	IV. (i) $\text{O}_3$ (ii) $\text{Zn-H}_2\text{O}$

Choose the correct answer from the options given below:

- (1) A-I, B-IV, C-II, D-III  
(2) A-IV, B-I, C-III, D-II  
(3) A-III, B-I, C-II, D-IV  
(4) A-IV, B-I, C-II, D-III

**68. Activation energy of any chemical reaction can be calculated if one knows the value of:**

- (1) Rate constant at two different temperatures
  - (2) Rate constant at standard temperature
  - (3) Probability of collision
  - (4) Orientation of reactant molecules during collision
- 

**69. The most stable carbocation among the following is:**

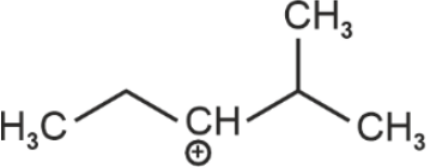
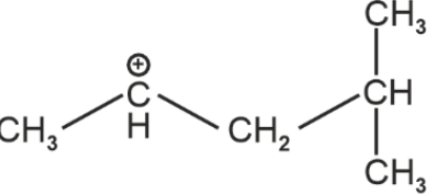
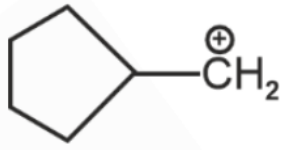
- (1)   
A cyclohexane ring with a methyl group (CH<sub>3</sub>) attached to the top carbon. The carbon atom at the top of the ring, which is also bonded to the methyl group, has a positive charge (+).
  - (2)   
A skeletal structure of a 3-methylbutyl cation. The chain is H<sub>3</sub>C-CH<sub>2</sub>-CH<sup>+</sup>-CH(CH<sub>3</sub>)-CH<sub>3</sub>. The positive charge is on the third carbon from the left.
  - (3)   
A skeletal structure of a tert-butyl cation. A central carbon atom has a positive charge (+) and is bonded to three methyl groups (CH<sub>3</sub>). One methyl group is to the left, one is below, and one is to the right.
  - (4)   
A cyclopentane ring with a -CH<sub>2</sub><sup>+</sup> group attached to one of the ring carbons.
- 

**70. Given below are two statements:**

**Statement I:** The boiling point of three isomeric pentanes follows the order



**Statement II:** When branching increases, the molecule attains a spherical shape, reducing surface area for contact and weakening intermolecular forces, thereby lowering the boiling point.

Choose the most appropriate answer:

- (1) Statement I is incorrect but Statement II is correct
  - (2) Both Statement I and Statement II are correct
  - (3) Both Statement I and Statement II are incorrect
  - (4) Statement I is correct but Statement II is incorrect
- 

**71. Which one of the following alcohols reacts instantaneously with Lucas reagent?**

- (1) 
$$\begin{array}{c} \text{CH}_3 \\ | \\ \text{CH}_3 - \text{C} - \text{OH} \\ | \\ \text{CH}_3 \end{array}$$
- (2)  $\text{CH}_3 - \text{CH}_2 - \text{CH}_2 - \text{CH}_2\text{OH}$
- (3) 
$$\begin{array}{c} \text{CH}_3 - \text{CH}_2 - \text{CH} - \text{OH} \\ | \\ \text{CH}_3 \end{array}$$
- (4) 
$$\begin{array}{c} \text{CH}_3 - \text{CH} - \text{CH}_2\text{OH} \\ | \\ \text{CH}_3 \end{array}$$
- 

**72. The Henry's law constant ( $K_H$ ) values of three gases (A, B, C) in water are 145,  $2 \times 10^{-5}$ , and 35 kbar, respectively. The solubility of these gases in water follows the order:**

- (1)  $A > B > C$
  - (2)  $B > A > C$
  - (3)  $B > C > A$
  - (4)  $A > C > B$
- 

**73. Which plot of  $\ln k$  vs  $\frac{1}{T}$  is consistent with the Arrhenius equation?**

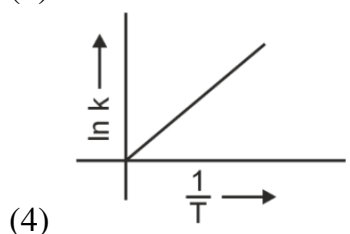
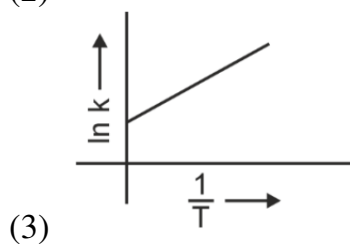
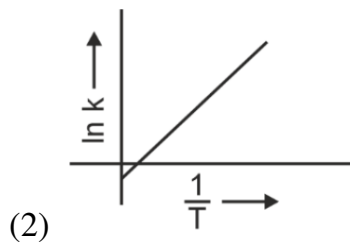
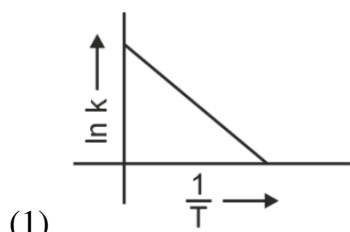



---

**74. On heating, some solid substances change from solid to vapour state without passing through liquid state. The technique used for the purification of such solid substances based on the above principle is known as**

- (A) Chromatography
  - (B) Crystallization
  - (C) Sublimation
  - (D) Distillation
- 

**75. Intramolecular hydrogen bonding is present in**

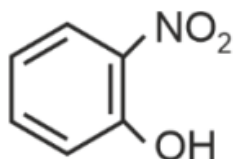
- (1) HF



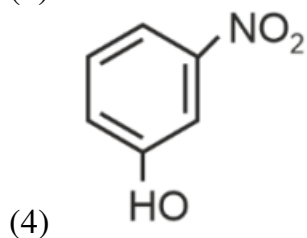
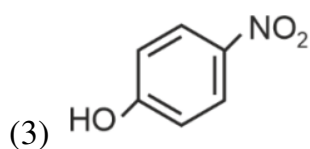

---

**76. 1 gram of sodium hydroxide was treated with 25 mL of 0.75 M HCl solution, the mass of sodium hydroxide left unreacted is equal to:**

- (A) 200 mg
- (B) 750 mg
- (C) 250 mg
- (D) Zero mg

---

**77. Which reaction is NOT a redox reaction?**

- (A)  $\text{BaCl}_2 + \text{Na}_2\text{SO}_4 \rightarrow \text{BaSO}_4 + 2\text{NaCl}$  (Correct Answer)
- (B)  $\text{Zn} + \text{CuSO}_4 \rightarrow \text{ZnSO}_4 + \text{Cu}$
- (C)  $2\text{KClO}_3 + \text{I}_2 \rightarrow 2\text{KIO}_3 + \text{Cl}_2$
- (D)  $\text{H}_2 + \text{Cl}_2 \rightarrow 2\text{HCl}$

---

**78. 'Spin only' magnetic moment is same for which of the following ions?**

- (A)  $\text{Ti}^{3+}$
- (B)  $\text{Cr}^{2+}$
- (C)  $\text{Mn}^{2+}$
- (D)  $\text{Fe}^{2+}$
- (E)  $\text{Sc}^{3+}$

Choose the most appropriate answer from the options given below:

- (1) A and D only
- (2) B and D only
- (3) A and E only

(4) B and C only

---

**79. The highest number of helium atoms is in**

- (1) 2.271098 L of helium at STP
  - (2) 4 mol of helium
  - (3) 4 u of helium
  - (4) 4 g of helium
- 

**80. Match List I with List II.**

List I (Complex)	List II (Type of isomerism)
A. $[\text{Co}(\text{NH}_3)_5(\text{NO}_2)]\text{Cl}_2$	I. Solvate isomerism
B. $[\text{Co}(\text{NH}_3)_5(\text{SO}_4)]\text{Br}$	II. Linkage isomerism
C. $[\text{Co}(\text{NH}_3)_6][\text{Cr}(\text{CN})_6]$	III. Ionization isomerism
D. $[\text{Co}(\text{H}_2\text{O})_6]\text{Cl}_3$	IV. Coordination isomerism

**Choose the correct answer from the options given below:**

- (1) A-II, B-IV, C-III, D-I
  - (2) A-II, B-III, C-IV, D-I
  - (3) A-I, B-III, C-IV, D-II
  - (4) A-I, B-IV, C-III, D-II
- 

**81. Given below are two statements:**

**Statement I:** The boiling point of hydrides of Group 16 elements follows the order

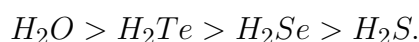

**Statement II:** On the basis of molecular mass,  $\text{H}_2\text{O}$  is expected to have a lower boiling point than the other members of the group, but due to the presence of extensive H-bonding in  $\text{H}_2\text{O}$ , it has a higher boiling point.

In the light of the above statements, choose the correct answer from the options given below:

- (1) Statement I is false but Statement II is true
- (2) Both Statement I and Statement II are true

- (3) Both Statement I and Statement II are false  
(4) Statement I is true but Statement II is false
- 

**82. A compound with a molecular formula of  $C_6H_{14}$  has two tertiary carbons. Its IUPAC name is:**

Choose the correct answer from the options given below:

- (1) 2,2-dimethylbutane  
(2) n-hexane  
(3) 2-methylpentane  
(4) **2,3-dimethylbutane**
- 

**83. Match List I with List II.**

{List-I (Conversion)}	List-II (Number of Faraday required)
A. 1 mol of $H_2O$ to $O_2$	I. 3F
B. 1 mol of $MnO_4^-$ to $Mn^{2+}$	II. 2F
C. 1.5 mol of Ca from molten $CaCl_2$	III. 1F
D. 1 mol of $FeO$ to $Fe_2O_3$	IV. 5F

- (1) A-III, B-IV, C-II, D-I  
(2) A-II, B-IV, C-I, D-III  
(3) A-III, B-IV, C-I, D-II  
(4) A-II, B-III, C-I, D-IV
- 

**84. The compound that will undergo  $S_N1$  reaction with the fastest rate is:**

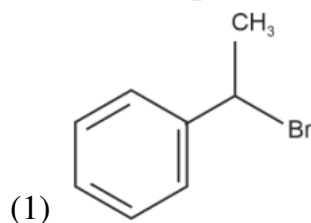

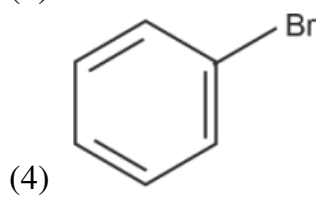
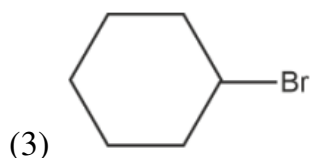
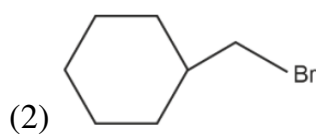

---

**85. Arrange the following elements in increasing order of electronegativity:**

N, O, F, C, Si

Choose the correct answer from the options given below:

(A)  $F < O < N < C < Si$

(B)  $Si < C < N < O < F$

(C)  $Si < C < O < N < F$

(D)  $O < F < N < C < Si$

---

**86. Major products A and B formed in the following reaction sequence, are:**

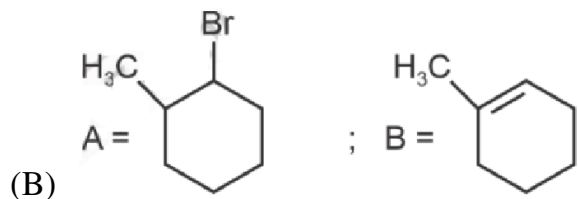
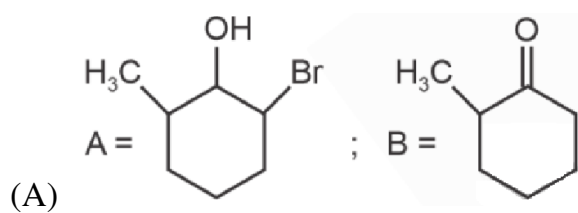
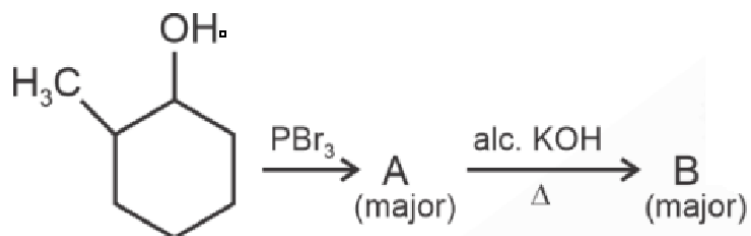

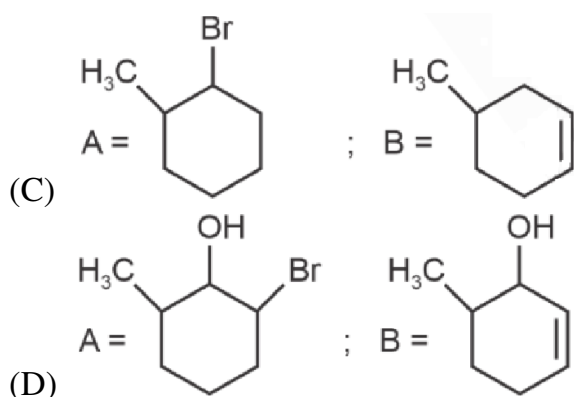

**87. Identify the correct answer.**

- (A) Three canonical forms can be drawn for  $CO_3^{2-}$  ion  
 (B) Three resonance structures can be drawn for ozone  
 (C)  $BF_3$  has non-zero dipole moment  
 (D) Dipole moment of  $NF_3$  is greater than that of  $NH_3$

**88. The work done during reversible isothermal expansion of one mole of hydrogen gas at  $25^\circ\text{C}$  from a pressure of 20 atmosphere to 10 atmosphere is**

(Given  $R = 2.0 \text{ cal } K^{-1} \text{ mol}^{-1}$ )

- (A) 100 calories  
 (B) 0 calorie  
 (C)  $-413.14$  calories  
 (D)  $413.14$  calories

**89. Consider the following reaction in a sealed vessel at equilibrium with given concentrations:**

$$N_2 = 3.0 \times 10^{-3} M, \quad O_2 = 4.2 \times 10^{-3} M, \quad NO = 2.8 \times 10^{-3} M.$$

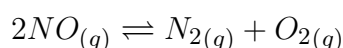

**If  $0.1 \text{ mol L}^{-1}$  of  $NO_{(g)}$  is taken in a closed vessel, determine the degree of dissociation ( $\alpha$ ) at equilibrium.**

- (A) 0.717

- (B) 0.00889  
(C) 0.0889  
(D) 0.8889
- 

90. For the given reaction:

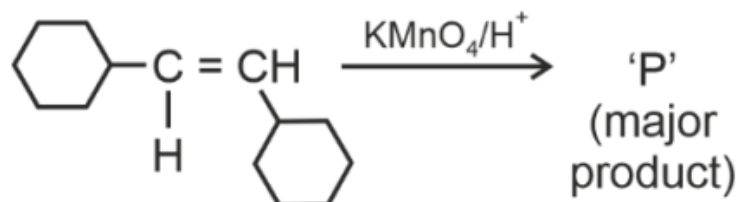

'P' is

- (1)
- (2)
- (3)
- (4)
- 

91. The pair of lanthanoid ions which are diamagnetic is:

- (1)  $\text{Pm}^{3+}$  and  $\text{Sm}^{3+}$   
(2)  $\text{Ce}^{4+}$  and  $\text{Yb}^{2+}$   
(3)  $\text{Ce}^{3+}$  and  $\text{Eu}^{2+}$   
(4)  $\text{Gd}^{3+}$  and  $\text{Eu}^{3+}$
- 

92. The products A and B obtained in the following reactions, respectively, are:

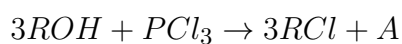

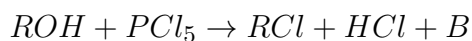

- (1)  $H_3PO_3$  and  $PCl_3$
  - (2)  $PCl_3$  and  $H_3PO_3$
  - (3)  $POCl_3$  and  $H_3PO_4$
  - (4)  $H_3PO_4$  and  $PCl_3$
- 

**93. Given below are certain cations. Using inorganic qualitative analysis, arrange them in increasing group number from 0 to VI.**

- (A)  $Al^{3+}$
- (B)  $Cu^{2+}$
- (C)  $Ba^{2+}$
- (D)  $Co^{2+}$
- (E)  $Mg^{2+}$

Choose the correct answer from the options given below:

- (1) E, A, B, C, D
  - (2) B, A, D, C, E
  - (3) B, C, A, D, E
  - (4) E, C, D, B, A
- 

**94. Given below are two statements:**

**Statement I:**  $[Co(NH_3)_6]^{3+}$  is a homoleptic complex, whereas  $[Co(NH_3)_4Cl_2]^+$  is a heteroleptic complex.

**Statement II:** Complex  $[Co(NH_3)_6]^{3+}$  has only one kind of ligands but  $[Co(NH_3)_4Cl_2]^+$  has more than one kind of ligands.

In light of the above statements, choose the *correct* answer from the options given below.

- (A) Statement I is false, but Statement II is true
- (B) Both Statement I and Statement II are true
- (C) Both Statement I and Statement II are false
- (D) Statement I is true, but Statement II is false

---

**95. A compound X contains 32% of A, 20% of B, and the remaining percentage of C. Determine its empirical formula.**

(Given atomic masses: A = 64; B = 40; C = 32 u)

- (A)  $ABC_4$
  - (B)  $A_2BC_2$
  - (C)  $ABC_3$
  - (D)  $AB_2C_2$
- 

**96. The plot of osmotic pressure ( $\Pi$ ) vs concentration ( $\text{mol L}^{-1}$ ) for a solution gives a straight line with slope  $25.73 \text{ L bar mol}^{-1}$ . The temperature at which the osmotic pressure measurement is performed is:**

(Use  $R = 0.083 \text{ L bar mol}^{-1} \text{ K}^{-1}$ )

- (A)  $12.05^\circ\text{C}$
  - (B)  $37^\circ\text{C}$
  - (C)  $310^\circ\text{C}$
  - (D)  $25.73^\circ\text{C}$
- 

**97. Identify the major product C formed in the following reaction sequence:**

**Reaction:**

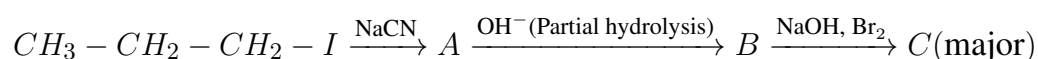

- (A)  $\alpha$ -bromobutanoic acid
  - (B) propylamine
  - (C) butylamine
  - (D) butanamide
- 

**98. During the preparation of Mohr's salt solution (Ferrous ammonium sulphate), which of the following acids is added to prevent hydrolysis of  $Fe^{2+}$  ion?**

- (A) dilute sulphuric acid
- (B) dilute hydrochloric acid

- (C) concentrated sulphuric acid  
(D) dilute nitric acid
- 

**99. The rate of a reaction quadruples when temperature changes from  $27^{\circ}\text{C}$  to  $57^{\circ}\text{C}$ .**

**Calculate the energy of activation.**

(Given  $R = 8.314 \text{ J K}^{-1} \text{ mol}^{-1}$ ,  $\log 4 = 0.6021$ )

- (A) 3804 kJ/mol  
(B) 38.04 kJ/mol  
(C) 380.4 kJ/mol  
(D) 3.80 kJ/mol
- 

**100. Mass in grams of copper deposited by passing 9.6487 A current through a voltmeter containing copper sulphate solution for 100 seconds is (Given: Molar mass of Cu:  $63 \text{ g mol}^{-1}$ ,  $1 \text{ F} = 96487 \text{ C}$ )**

- (A) 0.0315 g  
(B) 3.15 g  
(C) 0.315 g  
(D) 31.5 g
- 

## BOTANY

### SECTION-A

**101. The cofactor of the enzyme carboxypeptidase is:**

- (A) Haem  
(B) Zinc  
(C) Niacin  
(D) Flavin
- 

**102. Given below are two statements:**

**Statement I:** Parenchyma is living but collenchyma is dead tissue.

**Statement II:** Gymnosperms lack xylem vessels, but xylem vessels are characteristic of angiosperms.

Choose the correct answer from the options given below:

- (A) Statement I is false but Statement II is true
  - (B) Both Statement I and Statement II are true
  - (C) Both Statement I and Statement II are false
  - (D) Statement I is true but Statement II is false
- 

**103. Spindle fibers attach to kinetochores of chromosomes during:**

- (A) Telophase
  - (B) Prophase
  - (C) Metaphase
  - (D) Anaphase
- 

**104. In a plant, black seed color (BB/Bb) is dominant over white seed color (bb). In order to find out the genotype of the black seed plant, with which of the following genotype will you cross it?**

- (A) BB/Bb
  - (B) BB
  - (C) bb
  - (D) Bb
- 

**105. The equation of Verhulst-Pearl logistic growth is:**

$$\frac{dN}{dt} = rN \left[ \frac{K - N}{K} \right]$$

**From this equation,  $K$  indicates:**

- (A) Population density
  - (B) Intrinsic rate of natural increase
  - (C) Biotic potential
  - (D) Carrying capacity
- 

**106. How many molecules of ATP and NADPH are required for every molecule of  $CO_2$**

**fixed in the Calvin cycle?**

- (A) 3 molecules of ATP and 2 molecules of NADPH
  - (B) 2 molecules of ATP and 3 molecules of NADPH
  - (C) 2 molecules of ATP and 2 molecules of NADPH
  - (D) 3 molecules of ATP and 3 molecules of NADPH
- 

**107. Match List I with List II.**

List I (Microorganism)	List II (Product)
A. <i>Clostridium butylicum</i>	I. Ethanol
B. <i>Saccharomyces cerevisiae</i>	II. Streptokinase
C. <i>Trichoderma polysporum</i>	III. Butyric acid
D. <i>Streptococcus sp.</i>	IV. Cyclosporin-A

- (A) A-IV, B-I, C-II, D-III
  - (B) A-III, B-I, C-II, D-IV
  - (C) A-II, B-IV, C-III, D-I
  - (D) A-III, B-I, C-IV, D-II
- 

**108. These are regarded as major causes of biodiversity loss:**

- A. Over exploitation
- B. Co-extinction
- C. Mutation
- D. Habitat loss and fragmentation
- E. Migration

Choose the correct option:

- (A) A, B and D only
- (B) A, C and D only
- (C) A, B, C and D only

(D) A, B and E only

---

**109. Given below are two statements:**

**Statement I:** Chromosomes become gradually visible under light microscope during leptotene stage.

**Statement II:** The beginning of diplotene stage is recognized by dissolution of synaptonemal complex.

In the light of the above statements, choose the correct answer from the options given below:

- (A) Statement I is false but Statement II is true
  - (B) Both Statement I and Statement II are true
  - (C) Both Statement I and Statement II are false
  - (D) Statement I is true but Statement II is false
- 

**110. Auxin is used by gardeners to prepare weed-free lawns. But no damage is caused to grass as auxin**

- (A) can help in cell division in grasses, to produce growth.
  - (B) promotes apical dominance.
  - (C) promotes abscission of mature leaves only.
  - (D) does not affect mature monocotyledonous plants.
- 

**111. A pink flowered Snapdragon plant was crossed with a red flowered Snapdragon plant. What type of phenotype/s is/are expected in the progeny?**

- (A) Red, Pink as well as white flowered plants
  - (B) Only red flowered plants
  - (C) Red flowered as well as pink flowered plants
  - (D) Only pink flowered plants
- 

**112. Which of the following are required for the dark reaction of photosynthesis?**

- A. Light
- B. Chlorophyll
- C. CO<sub>2</sub>

D. ATP

E. NADPH

- (A) D and E only
  - (B) A, B and C only
  - (C) B, C and D only
  - (D) C, D and E only
- 

**113. The lactose present in the growth medium of bacteria is transported to the cell by the action of**

- (A) Polymerase
  - (B) Beta-galactosidase
  - (C) Acetylase
  - (D) Permease
- 

**114. Identify the type of flowers based on the position of calyx, corolla, and androecium with respect to the ovary from the given figures (a) and (b):**

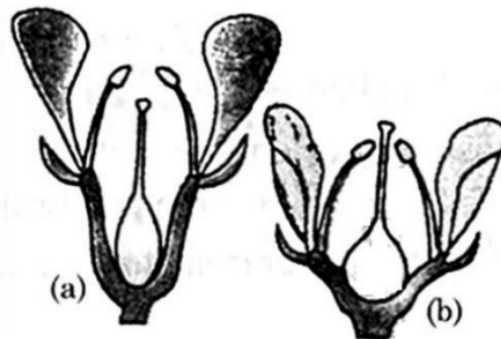

- (A) (a) Perigynous; (b) Perigynous
  - (B) (a) Epigynous; (b) Hypogynous
  - (C) (a) Hypogynous; (b) Epigynous
  - (D) (a) Perigynous; (b) Epigynous
- 

**115. Match List I with List II**

- (A) A-IV, B-III, C-II, D-I
- (B) A-III, B-II, C-IV, D-I

List-I	List-II
A. <i>Rhizopus</i>	I. Mushroom
B. <i>Ustilago</i>	II. Smut fungus
C. <i>Puccinia</i>	III. Bread mould
D. <i>Agaricus</i>	IV. Rust fungus

(C) A-I, B-III, C-II, D-IV

(D) A-III, B-II, C-I, D-IV

**116. The type of conservation in which the threatened species are taken out from their natural habitat and placed in a special setting where they can be protected and given special care is called:**

(A) Sustainable development

(B) *in-situ* conservation

(C) Biodiversity conservation

(D) Semi-conservative method

**117. Match List I with List II**

	List-I		List-II
A	Nucleolus	I	Site of formation of glycolipid
B	Centriole	II	Organization like the cartwheel
C	Leucoplasts	III	Site for active ribosomal RNA synthesis
D	Golgi apparatus	IV	For storing nutrients

Choose the correct answer from the options given below:

(1) A-I, B-II, C-III, D-IV

(2) A-III, B-II, C-IV, D-I

(3) A-II, B-III, C-I, D-IV

(4) A-III, B-IV, C-II, D-I

---

**118. The capacity to generate a whole plant from any cell of the plant is called:**

- (A) Somatic hybridization
  - (B) Totipotency
  - (C) Micropropagation
  - (D) Differentiation
- 

**119. Formation of interfascicular cambium from fully developed parenchyma cells is an example for**

- (A) Maturation
- (B) Differentiation
- (C) Redifferentiation
- (D) Dedifferentiation

**120. Which one of the following can be explained on the basis of Mendel's Law of Dominance?**

1. Out of one pair of factors one is dominant and the other is recessive.
2. Alleles do not show any expression and both the characters appear as such in  $F_2$  generation.
3. Factors occur in pairs in normal diploid plants.
4. The discrete unit controlling a particular character is called factor.
5. The expression of only one of the parental characters is found in a monohybrid cross.

- (A) A, B, C, D and E
- (B) A, B and C only
- (C) A, C, D and E only
- (D) B, C and D only

**121. What is the fate of a piece of DNA carrying only gene of interest which is transferred into an alien organism?**

1. The piece of DNA would be able to multiply itself independently in the progeny cells of the organism.

2. It may get integrated into the genome of the recipient.
3. It may multiply and be inherited along with the host DNA.
4. The alien piece of DNA is not an integral part of the chromosome.
5. It shows ability to replicate.

- (A) A and E only  
 (B) A and B only  
 (C) D and E only  
 (D) B and C only
- 

**122. Identify the part of the seed from the given figure which is destined to form root when the seed germinates.**

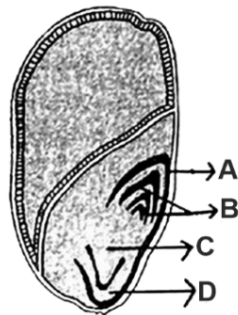

- (A) D  
 (B) A  
 (C) B  
 (D) C
- 

**123. Match List I with List II**

Choose the correct answer from the options given below:

- (1) A-IV, B-III, C-II, D-I
  - (2) A-I, B-II, C-III, D-IV
  - (3) A-II, B-I, C-II, D-III
  - (4) A-III, B-IV, C-I, D-II
- 

**124. Identify the set of correct statements:**

List I	List II
A. Two or more alternative forms of a gene	I. Back cross
B. Cross of F1 progeny with homozygous recessive parent	II. Ploidy
C. Cross of F1 progeny with any of the parents	III. Allele
D. Number of chromosome sets in plant	IV. Test cross

1. The flowers of *Vallisneria* are colourful and produce nectar.
2. The flowers of water lily are not pollinated by water.
3. In most of water-pollinated species, the pollen grains are protected from wetting.
4. Pollen grains of some hydrophytes are long and ribbon-like.
5. In some hydrophytes, the pollen grains are carried passively inside water.

- (A) B, C, D and E only  
 (B) C, D and E only  
 (C) A, B, C and D only  
 (D) A, C, D and E only

**125. Inhibition of Succinic dehydrogenase enzyme by malonate is a classical example of:**

- (A) Enzyme activation  
 (B) Cofactor inhibition  
 (C) Feedback inhibition  
 (D) Competitive inhibition

**126. List of endangered species was released by**

- (A) IUCN  
 (B) GEAC  
 (C) WWF  
 (D) FOAM

**127. Given below are two statements:**

**Statement I:** Bt toxins are insect group specific and coded by a gene *cry* IAc.

**Statement II:** Bt toxin exists as inactive protoxin in *B. thuringiensis*. However, after ingestion by the insect, the inactive protoxin gets converted into active form due to acidic pH of the insect gut.

In the light of the above statements, choose the correct answer from the options given below:

- (A) Statement I is false but Statement II is true
  - (B) Both Statement I and Statement II are true
  - (C) Both Statement I and Statement II are false
  - (D) Statement I is true but Statement II is false
- 

**128. Lecithin, a small molecular weight organic compound found in living tissues, is an example of:**

- (A) Carbohydrates
  - (B) Amino acids
  - (C) Phospholipids
  - (D) Glycerides
- 

**129. Which of the following is an example of actinomorphic flower?**

- (A) *Sesbania*
  - (B) *Datura*
  - (C) *Cassia*
  - (D) *Pisum*
- 

**130. Tropical regions show greatest level of species richness because**

- (A) Tropical latitudes have remained relatively undisturbed for millions of years, hence more time was available for species diversification.
- (B) Tropical environments are more seasonal.
- (C) More solar energy is available in tropics.
- (D) Constant environments promote niche specialization.
- (E) Tropical environments are constant and predictable.

- (A) A, B and D only
  - (B) A, C, D and E only
  - (C) A and B only
  - (D) A, B and E only
- 

**131. Hind II always cuts DNA molecules at a particular point called recognition sequence and it consists of:**

- (A) 10 bp
  - (B) 8 bp
  - (C) 6 bp
  - (D) 4 bp
- 

**132. Bulliform cells are responsible for**

- (A) Providing large spaces for storage of sugars.
  - (B) Inward curling of leaves in monocots.
  - (C) Protecting the plant from salt stress.
  - (D) Increased photosynthesis in monocots.
- 

**133. A transcription unit in DNA is defined primarily by the three regions in DNA and these are with respect to upstream and downstream end:**

- (A) Promoter, Structural gene, Terminator
  - (B) Repressor, Operator gene, Structural gene
  - (C) Structural gene, Transposons, Operator gene
  - (D) Inducer, Repressor, Structural gene
- 

**134. Which one of the following is not a criterion for classification of fungi?**

- (A) Fruiting body
- (B) Morphology of mycelium
- (C) Mode of nutrition
- (D) Mode of spore formation

**135. In the given figure, which component has thin outer walls and highly thickened**

inner walls?

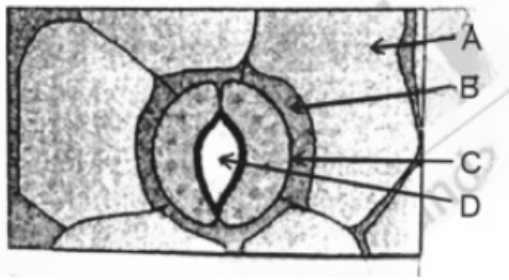

- (A) B
- (B) C
- (C) D
- (D) A

---

### SECTION-B

136. Match List I with List II

List I (Types of Stamens)	List II (Example)
A. Monadelphous	I. Citrus
B. Diadelphous	II. Pea
C. Polyadelphous	III. Lily
D. Epiphyllous	IV. China-rose

Choose the correct answer from the options given below:

- (1) A-III, B-I, C-IV, D-II
- (2) A-IV, B-II, C-I, D-III
- (3) A-IV, B-I, C-II, D-III
- (4) A-I, B-II, C-IV, D-III

---

137. The DNA present in chloroplast is:

- (1) Circular, single stranded
- (2) Linear, double stranded

- (3) Circular, double stranded
  - (4) Linear, single stranded
- 

**138. Read the following statements and choose the set of correct statements:**

**In the members of Phaeophyceae,**

- (A) Asexual reproduction occurs usually by biflagellate zoospores.
- (B) Sexual reproduction is by oogamous method only.
- (C) Stored food is in the form of carbohydrates which is either mannitol or laminarin.
- (D) The major pigments found are chlorophyll a, c and carotenoids and xanthophyll.
- (E) Vegetative cells have a cellulosic wall, usually covered on the outside by a gelatinous coating of algin.

**Choose the correct answer from the options given below:**

- (1) A, B, C and E only
  - (2) A, B, C and D only
  - (3) B, C, D and E only
  - (4) A, C, D and E only
- 

**139. Match List I with List II**

<b>List I</b>	<b>List II</b>
A. Citric acid cycle	I. Cytoplasm
B. Glycolysis	II. Mitochondrial matrix
C. Electron transport system	III. Intermembrane space of mitochondria
D. Proton gradient	IV. Inner mitochondrial membrane

**Choose the correct answer from the options given below:**

- (1) A-IV, B-III, C-II, D-I
  - (2) A-II, B-I, C-III, D-IV
  - (3) A-I, B-II, C-III, D-IV
  - (4) A-III, B-IV, C-I, D-II
-

**140. Given below are two statements:**

**Statement I:** In  $C_3$  plants, some  $O_2$  binds to RuBisCO, hence  $CO_2$  fixation is decreased.

**Statement II:** In  $C_4$  plants, mesophyll cells show very little photorespiration while bundle sheath cells do not show photorespiration.

**In the light of the above statements, Choose the correct answer from the options given below:**

- (1) Statement I is false but Statement II is true
  - (2) Both Statement I and Statement II are true
  - (3) Both Statement I and Statement II are false
  - (4) Statement I is true but Statement II is false
- 

**141. Which of the following statement is correct regarding the process of replication in *E. coli*?**

- (1) The DNA dependent DNA polymerase catalyses polymerization in  $5' \rightarrow 3'$  direction
  - (2) The DNA dependent DNA polymerase catalyses polymerization in one direction that is  $3' \rightarrow 5'$
  - (3) The DNA dependent RNA polymerase catalyses polymerization in one direction, that is  $5' \rightarrow 3'$
  - (4) The DNA dependent DNA polymerase catalyses polymerization in  $5' \rightarrow 3'$  as well as  $3' \rightarrow 5'$  direction
- 

**142. Match List I with List II.**

List I	List II
A. Robert May	I. Species-Area relationship
B. Alexander von Humboldt	II. Long-term ecosystem experiment using outdoor plots
C. Paul Ehrlich	III. Global species diversity at about 7 million
D. David Tilman	IV. Rivet popper hypothesis

**Choose the correct answer from the options given below:**

- (1) A-III, B-IV, C-II, D-I

- (2) A-II, B-III, C-I, D-IV  
 (3) A-III, B-I, C-IV, D-II  
 (4) A-I, B-III, C-II, D-IV

**143. Match List I with List II.**

List I	List II
A. Frederick Griffith	I. Genetic code
B. Francois Jacob & Jacque Monod	II. Semi-conservative mode of DNA replication
C. Har Gobind Khorana	III. Transformation
D. Meselson & Stahl	IV. Lac operon

**Choose the correct answer from the options given below:**

- (1) A-IV, B-I, C-II, D-III  
 (2) A-III, B-II, C-I, D-IV  
 (3) A-III, B-IV, C-I, D-II  
 (4) A-II, B-III, C-IV, D-I

**144. In an ecosystem, if the Net Primary Productivity (NPP) of the first trophic level is  $100x \text{ kcal m}^{-2}\text{yr}^{-1}$ , what would be the GPP (Gross Primary Productivity) of the third trophic level of the same ecosystem?**

- (1)  $\frac{100x}{3} \text{ kcal m}^{-2}\text{yr}^{-1}$   
 (2)  $\frac{x}{10} \text{ kcal m}^{-2}\text{yr}^{-1}$   
 (3)  $x \text{ kcal m}^{-2}\text{yr}^{-1}$   
 (4)  $10x \text{ kcal m}^{-2}\text{yr}^{-1}$

**145. Match List I with List II.**

**Choose the correct answer from the options given below:**

- (1) A-II, B-III, C-IV, D-I  
 (2) A-II, B-IV, C-I, D-III  
 (3) A-I, B-II, C-III, D-IV

List I	List II
A. Rose	I. Twisted aestivation
B. Pea	II. Perigynous flower
C. Cotton	III. Drupe
D. Mango	IV. Marginal placentation

(4) A-IV, B-III, C-II, D-I

**146. Identify the correct description about the given figure:**

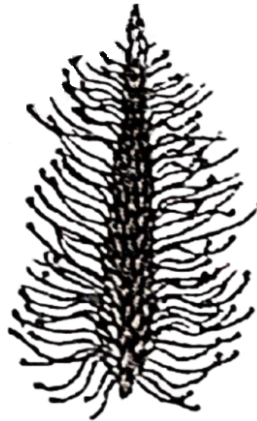

- (1) Compact inflorescence showing complete autogamy
- (2) Wind pollinated plant inflorescence showing flowers with well-exposed stamens.
- (3) Water pollinated flowers showing stamens with mucilaginous covering.
- (4) Cleistogamous flowers showing autogamy.

**147. Identify the step in the tricarboxylic acid cycle, which does not involve oxidation of substrate.**

- (1) Isocitrate  $\rightarrow$   $\alpha$ -ketoglutaric acid
- (2) Malic acid  $\rightarrow$  Oxaloacetic acid
- (3) Succinic acid  $\rightarrow$  Malic acid
- (4) Succinyl-CoA  $\rightarrow$  Succinic acid

**148. Spraying sugarcane crop with which of the following plant growth regulators**

**increases the length of the stem, thus, increasing the yield?**

- (1) Abscisic acid
  - (2) Auxin
  - (3) Gibberellin
  - (4) Cytokinin
- 

**149. Match List-I with List-II**

List-I	List-II
A. GLUT-4	I. Hormone
B. Insulin	II. Enzyme
C. Trypsin	III. ntercellular ground substance
D. Collagen	IV. Enables glucose transport into cells

Choose the correct answer from the options given below:

- (1) A-III, B-IV, C-I, D-II
  - (2) A-IV, B-I, C-II, D-III
  - (3) A-I, B-II, C-III, D-IV
  - (4) A-II, B-III, C-IV, D-I
- 

**150. Which of the following are fused in somatic hybridization involving two varieties of plants?**

- (1) Pollens
  - (2) Callus
  - (3) Somatic embryos
  - (4) Protoplasts
- 

## ZOOLOGY

### SECTION-A

**151. The flippers of the Penguins and Dolphins are an example of the:**

- (1) Divergent evolution

- (2) Adaptive radiation
  - (3) Natural selection
  - (4) Convergent evolution
- 

**152. Match List I with List II and choose the correct answer from the options given below:**

<b>List I</b>	<b>List II</b>
A. Pleurobrachia	I. Mollusca
B. Radula	II. Ctenophora
C. Stomochord	III. Osteichthyes
D. Air bladder	IV. Hemichordata

**Choose the correct answer from the options given below:**

- (1) A-IV, B-III, C-II, D-I
  - (2) A-IV, B-II, C-III, D-I
  - (3) A-II, B-I, C-IV, D-III
  - (4) A-II, B-IV, C-I, D-III
- 

**153. Which of the following is not a component of the Fallopian tube?**

- (1) Ampulla
  - (2) Uterine fundus
  - (3) Isthmus
  - (4) Infundibulum
- 

**154. Following are the stages of the pathway for conduction of an action potential through the heart:**

- A. AV bundle
- B. Purkinje fibres
- C. AV node
- D. Bundle branches
- E. SA node

Choose the correct sequence of the pathway from the options given below:

- (1) E-A-D-B-C
- (2) E-C-A-D-B
- (3) A-E-C-B-D
- (4) B-D-E-C-A

**155. Given below are two statements:**

**Statement I:** The presence or absence of hymen is not a reliable indicator of virginity.

**Statement II:** The hymen is torn during the first coitus only.

In the light of the above statements, choose the correct answer from the options given below:

- (1) Statement I is false but Statement II is true
- (2) Both Statement I and Statement II are true
- (3) Both Statement I and Statement II are false
- (4) Statement I is true but Statement II is false

**156. Match List I with List II:**

List I	List II
A. $\alpha$ -1 antitrypsin	I. Cotton bollworm
B. Cry IAb	II. ADA deficiency
C. Cry IAc	III. Emphysema
D. Enzyme replacement therapy	IV. Corn borer

Choose the correct answer from the options given below:

- (1) A-II, B-IV, C-I, D-III
- (2) A-II, B-I, C-IV, D-III
- (3) A-III, B-I, C-II, D-IV
- (4) A-III, B-IV, C-I, D-II

---

**157. Given below are two statements: one is labeled as Assertion (A) and the other as Reason (R):**

**Assertion A:** FSH acts upon ovarian follicles in females and Leydig cells in males.

**Reason R:** Growing ovarian follicles secrete estrogen in females, while interstitial cells secrete androgen in male human beings.

In the light of the above statements, choose the correct answer from the options given below:

- (1) A is false but R is true
  - (2) Both A and R are true and R is the correct explanation of A
  - (3) Both A and R are true but R is NOT the correct explanation of A
  - (4) A is true but R is false
- 

**158. Match List I with List II:**

List I	List II
A. Cocaine	I. <i>Effective sedative in surgery</i>
B. Heroin	II. <i>Cannabis sativa</i>
C. Morphine	III. <i>Erythroxyllum</i>
D. Marijuana	IV. <i>Papaver somniferum</i>

**Choose the correct answer from the options given below:**

- (1) A-III, B-IV, C-I, D-II
  - (2) A-IV, B-III, C-I, D-II
  - (3) A-I, B-III, C-II, D-IV
  - (4) A-II, B-I, C-III, D-IV
- 

**159. Match List I with List II:**

List I	List II
A. Lipase	I. Peptide bond
B. Nuclease	II. Ester bond
C. Protease	III. Glycosidic bond
D. Amylase	IV. Phosphodiester bond

Choose the correct answer from the options given below :

- (1) A-IV, B-I, C-III, D-II
  - (2) A-IV, B-II, C-III, D-I
  - (3) A-III, B-II, C-I, D-IV
  - (4) A-II, B-IV, C-I, D-III
- 

**160. Three types of muscles are given as (a), (b), and (c). Identify the correct matching pair along with their location in the human body:**

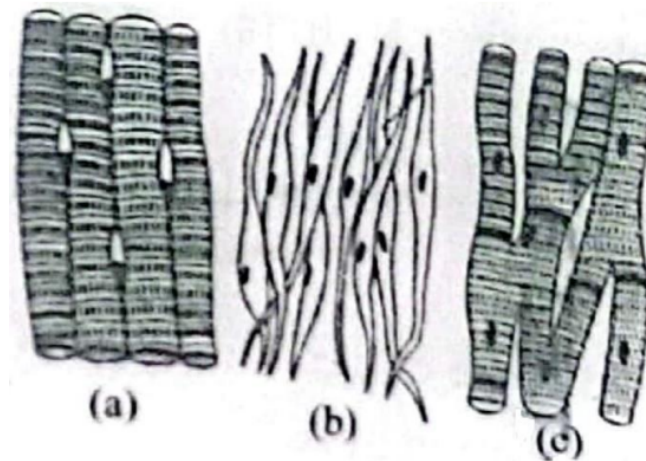

Name of muscle/location:

- (1) (a) Involuntary – Nose tip  
(b) Skeletal – Bone  
(c) Cardiac – Heart
- (2) (a) Smooth – Toes  
(b) Skeletal – Legs  
(c) Cardiac – Heart
- (3) (a) Skeletal – Triceps  
(b) Smooth – Stomach  
(c) Smooth – Heart
- (4) (a) Skeletal – Biceps  
(b) Involuntary – Intestine  
(c) Cardiac – Heart

**161. Match List I with List II:**

List I	List II
A. <i>Pterophyllum</i>	I. Hag fish
B. <i>Myxine</i>	II. Saw fish
C. <i>Pristis</i>	III. Angel fish
D. <i>Exocoetus</i>	IV. Flying fish

**Choose the correct answer from the options given below:**

- (1) A-III, B-II, C-I, D-IV
- (2) A-II, B-I, C-III, D-IV
- (3) A-III, B-I, C-II, D-IV
- (4) A-IV, B-I, C-II, D-III

**162. Match List I with List II :**

List I	List II
A. Fibrous joints	I. Adjacent vertebrae, limited movement
B. Cartilaginous joints	II. Humerus and Pectoral girdle, rotational movement
C. Hinge joints	III. skull, don't allow any movement
D. Ball and socket joints	IV. Knee, help in locomotion

**Choose the correct answer from the options given below:**

- (1) A-III, B-I, C-IV, D-II
- (2) A-IV, B-II, C-III, D-I
- (3) A-I, B-III, C-II, D-IV
- (4) A-II, B-III, C-I, D-IV

**163. Following are the stages of cell division:**

- A. Gap 2 (G<sub>2</sub>) phase
- B. Cytokinesis
- C. Synthesis (S) phase
- D. Karyokinesis
- E. Gap 1 (G<sub>1</sub>) phase

Choose the correct sequence of stages from the options given below:

- (1) E-C-A-D-B
- (2) C-E-D-A-B
- (3) E-B-D-A-C
- (4) B-D-E-A-C

**164. The “Ti plasmid” of *Agrobacterium tumefaciens* stands for:**

- (1) Temperature independent plasmid
- (2) Tumour inhibiting plasmid
- (3) Tumor independent plasmid
- (4) Tumor inducing plasmid

**165. Match List I with List II:**

List I	List II
A. Pons	I. Provides additional space for Neurons, regulates posture and balance.
B. Hypothalamus	II. Controls respiration and gastric secretions.
C. Medulla	III. Connects different regions of the brain.
D. Cerebellum	IV. Neuro secretory cells.

Choose the correct answer from the options given below (1) A-II, B-I, C-III, D-IV

- (2) A-II, B-III, C-I, D-IV
- (3) A-III, B-IV, C-II, D-I
- (4) A-I, B-III, C-II, D-IV

**166. Match List I with List II:**

List I	List II
A. Axoneme	I. Centriole
B. Cartwheel pattern	II. Cilia and flagella
C. Crista	III. Chromosome
D. Satellite	IV. Mitochondria

**Choose the correct answer from the options given below:**

- (1) A-II, B-I, C-IV, D-III
  - (2) A-IV, B-III, C-II, D-I
  - (3) A-IV, B-II, C-III, D-I
  - (4) A-II, B-IV, C-I, D-III
- 

**167. Consider the following statements:**

- A. Annelids are true coelomates
- B. Poriferans are pseudocoelomates
- C. Aschelminthes are acoelomates
- D. Platyhelminthes are pseudocoelomates

Choose the correct answer from the options given below:

- (1) D only
  - (2) B only
  - (3) A only
  - (4) C only
- 

**168. Which of the following is not a steroid hormone?**

- (1) Glucagon
  - (2) Cortisol
  - (3) Testosterone
  - (4) Progesterone
- 

**169. Given below are two statements:**

**Statement I:** In the nephron, the descending limb of the loop of Henle is impermeable to

water and permeable to electrolytes.

**Statement II:** The proximal convoluted tubule is lined by simple columnar brush border epithelium and increases the surface area for reabsorption.

In the light of the above statements, choose the correct answer from the options given below:

- (1) Statement I is false but Statement II is true
  - (2) Both Statement I and Statement II are true
  - (3) Both Statement I and Statement II are false
  - (4) Statement I is true but Statement II is false
- 

**170. Match List I with List II:**

List I	List II
A. Common cold	I. <i>Plasmodium</i>
B. Haemozoin	II. Typhoid
C. Widal test	III. Rhinoviruses
D. Allergy	IV. Dust mites

Choose the correct answer from the options given below:

- (1) A-IV, B-II, C-III, D-I
  - (2) A-II, B-IV, C-III, D-I
  - (3) A-I, B-III, C-II, D-IV
  - (4) A-III, B-I, C-II, D-IV
- 

**171. Match List I with List II and choose the correct answer from the options given below:**

	List I		List II
A.	Expiratory capacity	I.	Expiratory reserve volume + Tidal volume + Inspiratory reserve volume
B.	Functional residual capacity	II.	Tidal volume + Expiratory reserve volume
C.	Vital capacity	III.	Tidal volume + Inspiratory reserve volume
D.	Inspiratory capacity	IV.	Expiratory reserve volume + Residual volume

- (1) A-I, B-III, C-II, D-IV
- (2) A-II, B-IV, C-I, D-III

(3) A-III, B-II, C-IV, D-I

(4) A-II, B-I, C-IV, D-III

---

**172. Match List I (Sub Phases of Prophase I) with List II (Specific Characters) and choose the correct answer from the options given below:**

List I (Sub Phases of Prophase I)	List II (Specific Characters)
A. Diakinesis	I. Synaptonemal complex formation
B. Pachytene	II. Completion of terminalisation of chiasmata
C. Zygotene	III. Chromosomes look like thin threads
D. Leptotene	IV. Appearance of recombination nodules

(1)  $A - IV, B - III, C - II, D - I$

(2)  $A - IV, B - II, C - III, D - I$

(3)  $A - I, B - II, C - IV, D - III$

(4)  $A - II, B - IV, C - I, D - III$

---

**173. Given below are two statements: One is labelled as Assertion (A) and the other is labelled as Reason (R):**

**Assertion A:** Breast-feeding during the initial period of infant growth is recommended by doctors for bringing a healthy baby.

**Reason R:** Colostrum contains several antibodies absolutely essential to develop resistance for the newborn baby.

In the light of the above statements, choose the most appropriate answer from the options given below:

(1) A is not correct but R is correct

(2) Both A and R are correct and R is the correct explanation of A

(3) Both A and R are correct but R is NOT the correct explanation of A

(4) A is correct but R is not correct

---

**174. Which one of the following factors will not affect the Hardy-Weinberg**

**equilibrium?**

- (1) Constant gene pool
  - (2) Genetic recombination
  - (3) Genetic drift
  - (4) Gene migration
- 

**175. Match List I with List II:**

List I	List II
A. Typhoid	I. Fungus
B. Leishmaniasis	II. Nematode
C. Ringworm	III. Protozoa
D. Filariasis	IV. Bacteria

- (1) A-II, B-IV, C-III, D-I
- (2) A-I, B-III, C-II, D-IV
- (3) A-IV, B-III, C-I, D-II
- (4) A-III, B-I, C-IV, D-II

**Choose the correct answer from the options given below:**

---

**176. Given below are some stages of human evolution.**

Arrange them in the correct sequence (Past to Recent):

- A. *Homo habilis*
- B. *Homo sapiens*
- C. *Homo neanderthalensis*
- D. *Homo erectus*

Choose the correct sequence of human evolution from the options given below:

- (1) A-D-C-B
  - (2) D-A-C-B
  - (3) B-A-D-C
  - (4) C-B-D-A
- 

**177. The following diagram shows restriction sites in *E. coli* cloning vector pBR322.**

Find the role of 'X' and 'Y' genes:

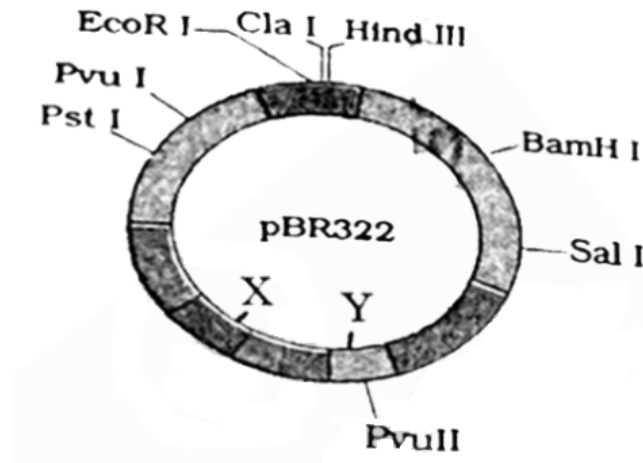

- (1) Gene 'X' is responsible for recognition sites and 'Y' is responsible for antibiotic resistance.
- (2) The gene 'X' is responsible for resistance to antibiotics and 'Y' for protein involved in the replication of plasmid.
- (3) The gene 'X' is responsible for controlling the copy number of the linked DNA and 'Y' for protein involved in the replication of plasmid.
- (4) The gene 'X' is for protein involved in replication of plasmid and 'Y' for resistance to antibiotics.

---

**178. Which of the following factors are favourable for the formation of oxyhaemoglobin in alveoli?**

- (1) Low  $p\text{CO}_2$  and High temperature
- (2) High  $p\text{O}_2$  and High  $p\text{CO}_2$
- (3) High  $p\text{O}_2$  and Lesser  $\text{H}^+$  concentration
- (4) Low  $p\text{CO}_2$  and High  $\text{H}^+$  concentration

---

**179. In both sexes of cockroach, a pair of jointed filamentous structures called anal cerci are present on:**

- (1) 11<sup>th</sup> segment
- (2) 5<sup>th</sup> segment
- (3) 10<sup>th</sup> segment
- (4) 8<sup>th</sup> and 9<sup>th</sup> segment

---

**180. Match List I with List II:**

<b>List I (Genetic Disorders)</b>	<b>List II(Chromosomal Association)</b>
A. Down's syndrome	I. 11 <sup>st</sup> chromosome
B. $\alpha$ -Thalassemia	II. 'X' <sup>th</sup> chromosome
C. $\beta$ -Thalassemia	III. 21 <sup>th</sup> chromosome
D. Klinefelter's syndrome	IV. 16 chromosome

Choose the correct answer from the options given below:

- (1) A-IV, B-I, C-II, D-III
  - (2) A-I, B-II, C-III, D-IV
  - (3) A-II, B-III, C-IV, D-I
  - (4) A-III, B-IV, C-I, D-II
- 

**181. Which of the following is not a natural/traditional contraceptive method?**

- (1) Vaults
  - (2) Coitus interruptus
  - (3) Periodic abstinence
  - (4) Lactational amenorrhea
- 

**182. Which of the following are Autoimmune disorders?**

- A. Myasthenia gravis
- B. Rheumatoid arthritis
- C. Gout
- D. Muscular dystrophy
- E. Systemic Lupus Erythematosus (SLE)

Choose the most appropriate answer from the options given below:

- (1) C, D & E only
- (2) A, B & D only
- (3) A, B & E only
- (4) B, C & E only

---

**183. Which of the following statements is incorrect?**

- (1) Bio-reactors have an agitator system, an oxygen delivery system and foam control system.
- (2) A bio-reactor provides optimal growth conditions for achieving the desired product.
- (3) Most commonly used bio-reactors are of stirring type.
- (4) Bio-reactors are used to produce small scale bacterial cultures.

**184. Match List I with List II:**

List I	Intrauterine Devices (IUDs) and Implants	List II	Examples
A.	Non-medicated IUD	I.	Multiload 375
B.	Copper releasing IUD	II.	Progestogens
C.	Hormone releasing IUD	III.	Lippes loop
D.	Implants	IV.	LNG-20

Choose the correct answer from the options given below:

- (1) A-III, B-I, C-IV, D-II
- (2) A-III, B-I, C-II, D-IV
- (3) A-I, B-III, C-IV, D-II
- (4) A-IV, B-I, C-II, D-III

---

**185. Which one is the correct product of DNA dependent RNA polymerase to the given template?**

**3' TACATGGCAAATATCCATTCA 5'**

- (1) 5'ATGTACCGTTTAAAGGTAAGT3'
- (2) 5'AUGUACCGUUUUAUAGGUAAGU3'
- (3) 5'AUGUAAAGUUUUAUAGGUAAGU3'
- (4) 5'AUGUACCGUUUUAUAGGGAAGU3'

---

**186. Given below are two statements:**

**Statement I:** The cerebral hemispheres are connected by a nerve tract known as corpus callosum.

**Statement II:** The brain stem consists of the medulla oblongata, pons, and cerebrum.

In the light of the above statements, choose the most appropriate answer from the options given below:

- (1) Statement I is incorrect but Statement II is correct.
  - (2) Both Statement I and Statement II are correct.
  - (3) Both Statement I and Statement II are incorrect.
  - (4) Statement I is correct but Statement II is incorrect.
- 

**187. Given below are two statements:**

**Statement I:** Gause's competitive exclusion principle states that two closely related species competing for different resources cannot exist indefinitely.

**Statement II:** According to Gause's principle, during competition, the inferior species will be eliminated if resources are limited.

In the light of the above statements, choose the correct answer from the options given below:

- (1) Statement I is false but Statement II is true.
  - (2) Both Statement I and Statement II are true.
  - (3) Both Statement I and Statement II are false.
  - (4) Statement I is true but Statement II is false.
- 

**188. Identify the correct Option (A), (B), (C), and (D) with respect to spermatogenesis.**

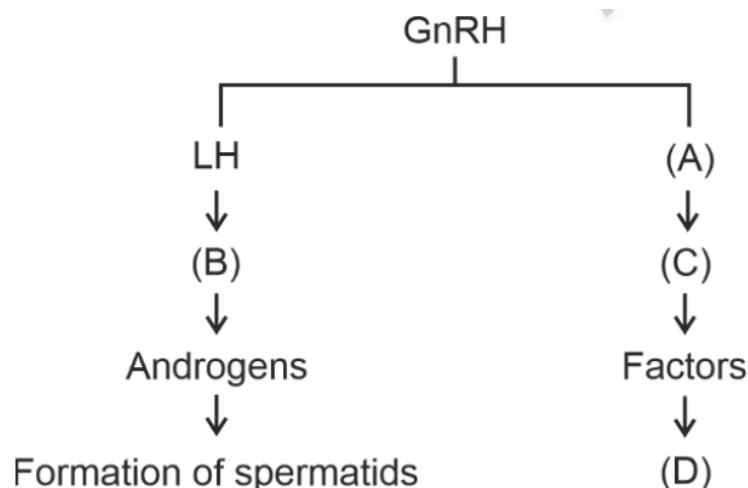

- (1) ICSH, Leydig cells, Sertoli cells, spermatogenesis.
- (2) FSH, Leydig cells, Sertoli cells, spermiogenesis.

(3) ICSH, Interstitial cells, Leydig cells, spermiogenesis.

(4) FSH, Sertoli cells, Leydig cells, spermatogenesis.

---

**189. The following are the statements about non-chordates:**

**A.** Pharynx is perforated by gill slits.

**B.** Notochord is absent.

**C.** Central nervous system is dorsal.

**D.** Heart is dorsal if present.

**E.** Post anal tail is absent.

Choose the most appropriate answer from the options given below:

(1) B, C & D only

(2) A & C only

(3) A, B & D only

(4) B, D & E only

---

**190. Match List I with List II:**

<b>List I</b>	<b>Epithelial Type</b>	<b>List II</b>	<b>Associated Organ</b>
A.	Unicellular glandular epithelium	I.	Salivary glands
B.	Compound epithelium	II.	Pancreas
C.	Multicellular glandular epithelium	III.	Goblet cells of alimentary canal
D.	Endocrine glandular epithelium	IV.	Moist surface of buccal cavity

Choose the correct answer from the options given below:

(1) A-II, B-I, C-IV, D-III

(2) A-I, B-III, C-III, D-IV

(3) A-IV, B-III, C-I, D-II

(4) A-III, B-IV, C-I, D-II

---

**191. Match List I with List II:**

	List I		List II
A.	P wave	I.	Heart muscles are electrically silent.
B.	QRS complex	II.	Depolarisation of ventricles.
C.	T wave	III.	Depolarisation of atria.
D.	T-P gap	IV.	Repolarisation of ventricles.

Choose the correct answer from the options given below:

- (1) A-IV, B-II, C-I, D-III
- (2) A-I, B-III, C-IV, D-II
- (3) A-III, B-II, C-IV, D-I
- (4) A-II, B-III, C-I, D-IV

**192. Match List I with List II:**

	List I		List II
A.	Exophthalmic goiter	I.	Excess secretion of cortisol, moon face & hyperglycemia.
B.	Acromegaly	II.	Hypo-secretion of thyroid hormone and stunted growth.
C.	Cushing's syndrome	III.	Hyper secretion of thyroid hormone & protruding eye balls.
D.	Cretinism	IV.	Excessive secretion of growth hormone.

Choose the correct answer from the options given below:

- (1) A-III, B-IV, C-I, D-II
- (2) A-I, B-III, C-II, D-IV
- (3) A-IV, B-II, C-I, D-III
- (4) A-III, B-IV, C-II, D-I

**193. Match List I with List II:**

<b>List I</b>	<b>List II</b>
A. Mesozoic Era	I. Lower invertebrates
B. Proterozoic Era	II. Fish & Amphibia
C. Cenozoic Era	III. Birds & Reptiles
D. Paleozoic Era	IV. Mammals

Choose the correct answer from the options given below:

- (1) A-III, B-I, C-IV, D-II
- (2) A-II, B-I, C-III, D-IV
- (3) A-III, B-I, C-IV, D-IV
- (4) A-I, B-II, C-IV, D-III

**194. Match List I with List II related to the digestive system of cockroach:**

<b>List I</b>	<b>List II</b>
A. The structures used for storing of food	I. Gizzard
B. Ring of 6-8 blind tubules at junction of foregut and midgut.	II. Gastric Caeca
C. Ring of 100-150 yellow coloured thin filaments at junction of midgut and hindgut.	III. Malpighian tubules
D. The structures used for grinding the food.	IV. Crop

Choose the correct answer from the options given below:

- (1) A-III, B-II, C-IV, D-I
- (2) A-IV, B-II, C-III, D-I
- (3) A-I, B-II, C-III, D-IV
- (4) A-IV, B-III, C-II, D-I

**195. Given below are two statements:**

**Statement I:** Bone marrow is the main lymphoid organ where all blood cells including lymphocytes are produced.

**Statement II:** Both bone marrow and thymus provide microenvironments for the development and maturation of T-lymphocytes.

In the light of the above statements, choose the most appropriate answer from the options given below:

- (1) Statement I is incorrect but Statement II is correct.
- (2) Both Statement I and Statement II are correct.
- (3) Both Statement I and Statement II are incorrect.
- (4) Statement I is correct but Statement II is incorrect.

**196. Match List I with List II:**

List I	Description	List II	Description
A.	RNA polymerase III	I.	snRNPs
B.	Termination of transcription	II.	Promoter
C.	Splicing of Exons	III.	Rho factor
D.	TATA box	IV.	SnRNAs, tRNA

Choose the correct answer from the options given below:

- (1) A-IV, B-III, C-I, D-II
- (2) A-II, B-IV, C-I, D-III
- (3) A-III, B-II, C-IV, D-I
- (4) A-III, B-IV, C-I, D-II

**197. Choose the correct statement given below regarding juxta medullary nephron.**

- (1) Juxta medullary nephrons outnumber the cortical nephrons.
- (2) Juxta medullary nephrons are located in the columns of Bertini.
- (3) Renal corpuscle of juxta medullary nephron lies in the outer portion of the renal medulla.
- (4) Loop of Henle of juxta medullary nephron runs deep into medulla.

**198. Given below are two statements:**

**Statement I:** Mitochondria and chloroplasts both double membranes bound organelles.

**Statement II:** Inner membrane of mitochondria is relatively less permeable, as compared to

chloroplast.

In the light of the above statements, choose the most appropriate answer from the options given below:

- (1) Statement I is incorrect but Statement II is correct.
  - (2) Both Statement I and Statement II are correct.
  - (3) Both Statement I and Statement II are incorrect.
  - (4) Statement I is correct but Statement II is incorrect.
- 

**199. Regarding catalytic cycle of an enzyme action, select the correct sequential steps:**

- A. Substrate enzyme complex formation.
- B. Free enzyme ready to bind with another substrate.
- C. Release of products.
- D. Chemical bonds of the substrate broken.
- E. Substrate binding to active site.

Choose the correct answer from the options given below:

- (1) E, D, C, B, A
  - (2) E, A, D, C, B
  - (3) A, E, B, D, C
  - (4) B, A, C, D, E
- 

**200. As per ABO blood grouping system, the blood group of father is B<sup>+</sup>, mother is A<sup>+</sup> and child is O<sup>+</sup>. Their respective genotype can be:**

- A.  $I^B I^A / ii$
- B.  $I^B I^B / I^A ii$
- C.  $I^A I^B / I^A I^B$
- D.  $I^A i / I^B I^A$
- E.  $ii I^B / I^A I^B$

Choose the most appropriate answer from the options given below:

- (1) D & E only
- (2) A only
- (3) B only

(4) C & B only

---